



SOUTHERN NEVADA REGIONAL HOUSING AUTHORITY

REQUEST FOR QUOTES, Q24008

**GENERAL CONTRACTORS:
REHABILITATION OF 802 MCWILLIAMS**

**THIS PROJECT IS SUBJECT TO DAVIS BACON WAGES, CERTIFIED PAYROLL
AND SNRHA'S SECTION 3 PROGRAM**

**RFQ Q24008
MARCH, 2024**

Submission Deadline:

Thurs., April 25th, 2024, 10:00AM

PROCUREMENT AND CONTRACTS DEPARTMENT

340 North 11th Street, Suite 180

Las Vegas, NV 89101

Tel: (702) 477-3144 - Fax: (702) 922-6648 - TDD: (702) 387-1898



**REQUEST FOR QUOTES
 TABLE OF CONTENTS**

SECTION	DESCRIPTION	PAGE
	SNRHA's NARRATIVE OF SERVICES	3
	IFB INFORMATION AT A GLANCE	4
1.0	SNRHA'S RESERVATION OF RIGHTS AND PROTEST PROCEDURES	5
1.1	SNRHA's Reservation of Rights	5
1.2	SNRHA's Protest Procedures	6
2.0	SCOPE OF WORK /TECHNICAL SPECIFICATIONS	9
2.1	Scope of Work	9
2.2	Work Site Location	9
2.3	Labor Rate	9
2.4	Time of Completion	9
2.5	Liquidated Damages	10
2.8	Government Standards: Safety	10
2.13	Technical Specifications	12
3.0	SOLICITATION PROCEDURES & SUBMISSION INSTRUCTIONS	12
3.1	Pre-Bid Conference and Site Visits	12
3.2	Question and Answer Deadline	12
3.3	Bid Submission Deadline and Public Bid Opening	13
3.4	Bid Guarantee and/or Bid Bond	13
3.5	Bid Submittal Format	13
3.7	Labor Standards: Labor Rate and Certified Payroll/Weekly Certified Form WH-37	16
4.0	CONTRACT EVALUATION AND AWARD	17
4.1	License & Insurance Requirements	17
5.0	CONTRACT STANDARDS	17
6.0	ATTACHMENTS	17



SNRHA's NARRATIVE OF SERVICES

Southern Nevada Regional Housing Authority (SNRHA), an Accredited Management Organization®, was formed in January 2010 through the consolidation of the three housing authorities in the Las Vegas Valley. The consolidated SNRHA is the 32nd largest public housing authority in the country and the 6th largest PHA in HUD Region 9, which encompasses California, Arizona, Nevada and Hawaii.

SNRHA has an annual budget of \$152 million and has received approximately \$20 million in American Recovery and Reinvestment Act (ARRA) funds. Further, the agency has received approximately \$13 million in Neighborhood Stabilization Program (NSP) funds.

SNRHA currently owns and manages 23 public housing properties, 386 scattered site units (single-family homes) totaling 2,651 public housing units. A total of 5,396 residents are served under this program. Of the 23 public housing properties 20 are conventional public housing, six (6) designated senior developments, four (4) designated as elderly/disabled developments, and ten (10) are designated as family developments. The remaining three (3) properties are Mixed Finance public housing properties, one (1) designated senior development, and two (2) are designated as family developments.

SNRHA also administers over 11,000 Housing Choice Vouchers (Section 8) that allow families to rent in the private market and receive a subsidy towards their rent. With this assistance, participants are able to pay approximately 30 percent of their annual adjusted income towards their rent, while the SNRHA pays the remainder. The SNRHA helps provide housing to approximately 28,841 participants under this program.

SNRHA owns and manages an additional 1,035 affordable housing units (non-subsidized) which includes two (2) mobile home parks, two (2) senior sites, four (4) family sites and 32 scattered site units (single-family homes) including 141 NSP single-family homes located in Clark County, Henderson and City of North Las Vegas. Additionally SNRHA manages 38 NSP single-family homes for the City of Las Vegas. The SNRHA helps provide housing to approximately 2,147 residents under this program.

SNRHA through its preservation efforts recently converted three (3) properties from Public Housing to Project Based Vouchers through the Rental Assistance and Demonstration Program (RAD) totaling 323 units, plus 8 HOME units serving a total of 881 residents under this program.

SNRHA has an extensive and honorable lineage as the successor to the Housing Authorities of Las Vegas, North Las Vegas, and Clark County. All of that expertise is now under one roof and we hope to serve our Southern Nevada residents and clients much more efficiently.

SNRHA is made-up of staff from diverse cultural, ethnic and racial backgrounds. We believe diversity promotes awareness and understanding, and allows creativity and openness to change. The SNRHA recognizes and celebrates workplace diversity and believes it is an essential part of our organization in order to face the challenges of the future.

Emerging Small Businesses (ESB), Minority, Women-Owned and Small Business Enterprises are encouraged to participate in this Solicitation Process. For additional information regarding ESB, please contact the Governor's Office at (702) 486-2700 or www.diversifynevada.com or esbprogram@diversifynevada.com



IFB INFORMATION AT A GLANCE

<p>SNRHA CONTACT PERSON(S) ONLY:</p> <p>Note: Contact with any other SNRHA staff other than the named within this document is prohibited and will result in your Proposal being rejected. This also includes contact with SNRHA's Residents and Board of Commissioners.</p>	<p>Ryan Perry Telephone: (702) 477-3142 TDD: (702) 387-1898 Email: https://nevada.ionwave.net/HomePage.aspx, or</p> <p>Johnny Shaw Telephone: (702) 477-3146 Email: jshaw@snrha.org</p>
<p>HOW TO OBTAIN THE SOLICITATION DOCUMENTS ON THE APPLICABLE INTERNET SITES:</p> <p>NOTE: Copies of bid documents received from sources other than the SNRHA will cause your bid to be deemed invalid.</p>	<p>1. To Only Download the Solicitation: www.snrha.org click on Procurement tab, click on "Current Bid Invitations" Downloading Questions: (702) 477-3160.</p> <p>2. To Respond, Q&A and Receive Addenda regarding this Solicitation: https://nevada.ionwave.net/HomePage.aspx and please note: you must first register your company in order to access this Solicitation.</p>
<p>PRE-BID CONFERENCE:</p> <p>SITE VISIT:</p>	<p>Thurs., March 28, 2024, 9:00 AM (PST), 802 McWilliams, LV, NV</p> <p>Thurs., March 28, 2024, following the Pre-Bid Conference:</p>
<p>QUESTION & ANSWER SUBMISSION DEADLINE:</p>	<p>Thurs., April 11, 2024 10:00AM (PST) All questions and answers must be submitted in writing to https://nevada.ionwave.net/HomePage.aspx. Questions and/or requests for clarification will not be responded to after the Q & A deadline date and time.</p>
<p>SEALED BID SUBMISSIONS:</p>	<p>Thurs., April 25, 2024, 10:00AM 2 sealed, hard-copy bids must be submitted by the stated deadline to: Southern Nevada Regional Housing Authority Procurement Department 340 N. 11th Street, Suite 180 Las Vegas, NV 89101</p> <p>Electronic bids must be submitted by the deadline date and time as well at https://nevada.ionwave.net/HomePage.aspx. One without the other will deem your bid non-responsive.</p> <p>No Public Bid Opening: Results will be posted on the noted websites. Sealed Bids must be received by SNRHA by the deadline date and time. Mailed bids must be post-marked prior to submission deadline to be considered. Unsealed or late bids will be rejected.</p>
<p>ANTICIPATED APPROVAL BY SNRHA BOARD</p>	<p>None</p>
<p>Emerging Small Business (ESB): Women, and/or minority-owned businesses are encouraged to participate in our Solicitation Processes. For full details of the ESB Program and for possible increased business opportunities, contact (702) 486-2700, www.diversifynevada.com or esbprogram@diversifynevada.com</p>	



1.0 SNRHA'S RESERVATION OF RIGHTS AND PROTEST PROCEDURES:

1.1 SNRHA's Reservation of Rights:

- 1.1.1** The SNRHA reserves the right to reject any or all proposals, to waive any informality in the Solicitation process, or to terminate the Solicitation process at any time, if deemed by the SNRHA to be in its best interests.
- 1.1.2** The SNRHA reserves the right not to award a contract pursuant to this Solicitation or award a contract to more than one Contractor if it deems it is necessary to do so.
- 1.1.3** The SNRHA reserves the right to terminate a contract awarded pursuant to this Solicitation, at any time for its convenience upon 10 days written notice to the successful bidder(s).
- 1.1.4** The SNRHA reserves the right to determine the days, hours and locations that the successful bidder(s) shall provide the services called for in this Solicitation.
- 1.1.5** The SNRHA reserves the right to retain all proposals submitted and not permit withdrawal for a period of 60 days subsequent to the deadline for receiving proposals without the written consent of the SNRHA Procurement Manager (PM).
- 1.1.6** The SNRHA reserves the right to negotiate the fees proposed by the bidder entity.
- 1.1.7** The SNRHA reserves the right to reject and not consider any proposal that does not meet the requirements of this Solicitation, including but not necessarily limited to incomplete proposals and/or proposals offering alternate or non-requested services.
- 1.1.8** The SNRHA shall have no obligation to compensate any bidder for any costs incurred in responding to this Solicitation.
- 1.1.9** The SNRHA reserves the right to accept only one Solicitation per company carrying the same Tax Identification Number.
- 1.1.10** SNRHA reserves the right and requires all contractors to comply with the American Disability Act (ADA) on all contracts which are as follows:
 - 1.1.10.1** Contractor agrees to comply with the federal statues relating to non-discrimination. These include, but aren't limited to Section 504 of the Rehabilitation Act of 1973 as amended (29USC section 794) which prohibits discrimination on the basis of handicap and the Americans with Disabilities Act of 1990.
 - 1.1.10.2** The Bidder agrees to abide by the requirements of the following as applicable; The Rehabilitation Act of 1973 as amended, the Vietnam Veterans Readjustment Assistance Act of 1974; the Requirements of the ADA of 1990. The Bidder agrees not to discriminate in its employment practices and will render services under this agreement and any contract entered into as a result of this agreement, without regard to veteran status or disabilities. Any failure to comply with these statutory obligations when applicable shall be grounds for termination of this agreement and any contract entered into as a result of this agreement.



- 1.1.11** The SNRHA reserves the right to reject and not consider any bid of which communication between a Bidder and a member of the SNRHA staff, its Residents or Board of Commissioners (BOC) is violated. Communication regarding this Solicitation is prohibited from the time the Solicitation is advertised until it is recommended for award of a contract. Questions pertaining to this Solicitation shall be addressed only to the "Designated Contact(s)" as specified on the previous page of this document. Failure to comply with this requirement shall result in the Proposal being considered nonresponsive
- 1.1.12** The SNRHA shall reserve the right to at any time during the IFB or contract process to prohibit any further participation by a bidder or reject any bid submitted that does not conform to any of the requirements detailed herein. By accessing the SNRHA websites at <https://nevada.ionwave.net/HomePage.aspx> and/or www.snrha.org and downloading and responding to this Solicitation, each prospective bidder is thereby agreeing to abide by all terms and conditions listed within this document and within the noted Internet site, and further agrees that he/she will inform the SNRHA PM in writing within 5 days of the discovery of any item listed herein or of any item that is issued thereafter by the SNRHA that he/she feels needs to be addressed. Failure to abide by this time frame shall relieve the SNRHA, but not the prospective bidder, of any responsibility pertaining to such issue.
- 1.2 Protest Procedures:** Any prospective or actual bidder, offeror, or contractor in connection with the solicitation of a bid or award of a contract, shall have the right to protest.
- 1.2.1** To be eligible to file a protest with the Public Housing Authority (PHA) pertaining to an award of contract, including small purchase, competitive proposal, or sealed bid the company or individual filing the protest must have been involved in the bid process in some manner (i.e. registered and received the solicitation documents) when the alleged situation occurred. The SNRHA has no obligation to consider a protest filed by any party that does not meet these criteria.
- 1.2.2** A Bidder who submits an unsuccessful bid may not seek any type of judicial intervention until the Executive Director/Contracting Officer (ED/CO) or his designate(s) have made a determination on the protest and awards the contracts.
- 1.2.3** Neither the BOC, ED/CO nor its authorized representative is liable for any costs, expenses, attorney's fees, loss of income or other damages sustained by a Bidder who submits a bid, whether or not the person files the protest pursuant to this section.
- 1.2.4** The CO shall review the written protest and supportive data, within ten (10) days after receipt of the written protest, issue a written opinion and decision. This document shall state the reasons for the action taken as well as inform the alleged aggrieved protestant of the right of further administrative review. A copy of this written opinion and decision shall be placed on file.
- 1.2.5** A Protest shall be in writing, and must include the following:
- 1.2.5.1** A bond;
 - 1.2.5.2** The name, address and phone number(s) of the protestor;
 - 1.2.5.3** The solicitation/contract number and project title;
 - 1.2.5.4** A detailed statement of the basis for the protest;
 - 1.2.5.5** Supporting evidence or documents to substantiate any arguments;



- 1.2.5.6 The form of relief or remedy requested;
- 1.2.5.7 All protests shall be submitted to the ED/CO or his/her designee;
- 1.2.5.8 The written protest of an award of contract must be received within ten (10) calendar days after bid result notification of the contract award has been sent to the protestor, or the protest will not be considered;
- 1.2.5.9 All written protest received by the SNRHA must be signed and date/time stamped upon receipt of the written protest;
- 1.2.5.10 Bond Requirement for Protest;
- 1.2.5.11 A bond or surety is required to be submitted with the protest documents (noted above);
- 1.2.5.12 A protest submitted without the bond or security shall not be considered;
- 1.2.6 **Protest Bond/Security:** A bond with good and solvent surety authorized to do business in this State of Nevada, or submit other security, defined as a cashier's check, money order or certified check, endorsed to the SNRHA. The bond or surety must be in an amount equal to 25% of the total value of the bid; and
- 1.2.7 A bond posted or other security must be submitted with the protest. SNRHA shall hold the bond or other security until a determination is made on the protest.
- 1.2.8 **Receipt of Protest:**
 - 1.2.8.1 Upon timely receipt of the protest, the ED/CO or designee shall review the protest and issue a written decision on the matter within a reasonable time. If the protest is denied, the written decision shall be a final decision, unless an appeal hearing is requested;
 - 1.2.8.2 SNRHA Legal Counsel may be obtained at the approval of the Executive Director/Contracting Officer (ED/CO) or the designate;
 - 1.2.8.3 Prior to submitting a response to a protest, the ED/CO must ensure compliance with HUD and other applicable regulations;
 - 1.2.8.4 If the protest has been generated by a legal firm then SNRHA Counsel at the discretion of the ED/CO and/or ED/CO shall prepare any all subsequent responses; and
 - 1.2.8.5 If a decision to deny the appeal/protest is unclear SNRHA may consult with legal counsel.
- 1.2.9 **Response to Protest:**
 - 1.2.9.1 The Contracting office shall review the written protest and supportive data, if any. He/she shall, within 10 days after receipt of the written protest, issue a written opinion and decision. This document shall state the reasons for the action taken as well as inform the alleged aggrieved protestant of the right of further administrative review. The ED/CO shall fully document the protest decision in writing in the contract file.



1.2.10 Denials of Protest:

1.2.10.1 The CO shall notify the protestor in writing of the SNRHA's decision and state the basis for the denial. The notification shall apprise the protestor of any appeal rights in accordance with the SNRHA's protest procedures.

1.2.10.2 **Note:** When the protest is denied, the SNRHA may make a claim against the bond or other security in an equal amount to the expenses incurred due to the unsuccessful protest. Any money remaining after the claim has been satisfied must be returned to the company/individual who posted the bond or submitted the security. A request for Appeal Hearing ceases this action until a final determination is made.

1.2.11 Protest – Appeal Hearing:

1.2.11.1 If the company or individual protesting does not agree with the written opinion and decision issued by the ED/CO, the protestor may request an Appeal Hearing.

1.2.12 Appeal Hearing Procedures:

1.2.12.1 The request for an appeal hearing must be delivered in writing (signed and date/time stamped) to the CO within five (5) calendar days of receipt of the written opinion and decision. Failure to request an appeal hearing within five (5) calendar days of receipt of the written opinion and decision or comply with the instructions below shall relieve the SNRHA of any responsibility to consider the request. The following procedures must be adhered to:

1.2.12.2 The request for an appeal hearing must contain the specific reasons for the appeal and all supporting data for those reasons.

1.2.12.3 After review of the request is submitted, it shall be within the administrative powers of the contracting officer to grant or deny any request for administrative appeal.

1.2.12.4 After a complete review of the alleged aggrieved protestant's written request and supporting data, if the ED/CO decides that the request does not merit further consideration, he/she shall render his/her decision in writing to the alleged aggrieved protestant. A decision rendered under this paragraph shall be made within 10 days after the receipt of the alleged aggrieved protestant's request for an administrative hearing. This decision shall be final without further administrative recourse.

1.2.12.5 After a complete review of the protest and findings, if the ED/CO decides that the request merits further consideration, he/she shall forward the protestant's written request, along with a cover letter explaining why it merits further consideration and with a recap of all proposals submitted and a copy of the original written protest, to the SNRHA Legal Counsel for consideration. The 10 days of his/her receipt of such documents.

1.2.12.6 Such written decision delivered to the Protester shall exhaust the SNRHA's internal protest and administrative appeal process available.



2.0 SCOPE OF WORK AND TECHNICAL SPECIFICATIONS FOR QUALIFIED GENERAL CONTRACTORS:

The successful Bidder shall possess all of the required state and local licenses, and certifications required to perform work of the type required by this RFQ in the State of Nevada, County of Clark and provide copies to SNRHA.

2.1 Scope of Work: General Contractor shall provide labor, materials and equipment as required for the complete Rehabilitation of Wind Damaged Unit at the following service site stated in Section 2.2. All work to be provided shall be pursuant to the specifications and Scope of Work as described within this RFQ Package and any additional Addenda. **(See Attachment H for complete Scope of Work)**

2.2 Work Site Location: 802 McWilliams, Las Vegas, NV 89106

2.3 Labor Rate: Bidder/Contractor's bid is based on the current Davis Bacon Wage Rate requirements. **Department of Labor (DOL) Davis Bacon Wage Rates Decision No. NV20240042, 1/5/2024 (See Attachment C).**

Bidder/Contractor and all subcontractors must meet current state minimum wage requirements. Davis Bacon Wages is applicable to this project and the current Wage Decision is attached. The following information must be provided to the SNRHA's Davis Bacon Specialist, Irma Solis, at isolis@sivrha.org regarding contracted employees:

2.3.1.1 List of Employees

2.3.1.2 Job Title

2.3.1.3 Description of Work Duties

Note: At any time employees are removed or replaced during the term of this contract the SNRHA shall be promptly notified of the change and provided the required information for the new employee.

2.4 Time of Completion for Total Project: The work on the site shall be substantially completed **within sixty days (60 calendar days after the Contractor receives the Notice to Proceed.** Completion shall be further defined as "Substantial Completion" of the work in progress to include but not limited to:

2.4.1 All final inspections and Certificate of Occupancy Inspections are approved by Clark County Nevada and any other agency having jurisdiction over the project as required.

2.4.2 Minor punch list items: If the work does not require a permit from a local jurisdiction, only minor punch list items will be considered for remaining work. Minor punch list items shall be defined as: adjusting components, touch up paint, minor clean-up, not to include hauling debris away from the site, etc.

2.4.3 When a project is declared "**Substantially Completed**" the only work left to complete will be minor punch-list items.

2.4.4 The Contractor shall notify the SNRHA in writing when the job is considered substantially complete and the requirements in Section 2.4 have been met. Lack of written notification will result in the accrual of contract time until written notice is received.

2.4.5 The SNRHA must have the concurrence of the Engineer/Professional of Record before the job is considered "Substantially Complete".



- 2.4.6 Final payment application (10% retention) cannot be released until the punch list has been completed, all certified payroll issues have been addressed and all close-out documents have been received and approved by the SNRHA.
- 2.5 **Liquidated Damages: Refer to Form HUD 5370, Section 33, p12:** As actual damages for any delay in completion are impossible to determine, the Contractor and his sureties shall be liable for and shall pay to the SNRHA **the sum of \$200.00 per dwelling unit per day** as fixed, agreed and liquidated damages for each calendar day of delay until the work is completed and accepted.
- 2.6 Bidder/Contractor shall comply with all laws, ordinances, and regulations applicable to the specifications herein and are to be familiar with all Federal, State and local laws, ordinances, codes, rules and regulations that may in anyway affect the delivery of Contractor's services.
- 2.7 Bidder/Contractor shall be responsible for submitting regular reports detailing their compliance with the conditions of the contract awarded in the format prescribed by, and bat the intervals required by SNRHA. These include, but are not limited to payroll reports, certifications and other various forms required by HUD.
- 2.8 **Government Standards – Safety:**
Safety Plan for Construction and Maintenance Contracts: Bidder/Contractor shall have in place a Safety Plan for its company that shall be in accordance with OSHA Regulations and include a Training Plan for its employees. Bidder/Contractor shall use safety devices in accordance with the applicable laws and regulations pursuant to the work performed under this IFB so as to ensure public safety. Bidder/Contractor shall take all steps necessary to ensure that work area is properly secured to provide the reasonable safeguard of persons, property and to prevent exposure to unsafe conditions. Bidder/Contractor shall ensure that all devices and chemicals used are in accordance with OSHA and EPA and any other state, federal, county and city regulations. Bidder/Contractor shall provide MSDS for all products and devices used in providing the service and shall provide a copy of their Safety and Training Plan to the SNRHA.

Note: All supervisors must possess an OSHA 30 Certification and all other employees an OSHA 10 Certification. Please place your Safety and Training Plan as pursuant to OSHA Regulations under Tab 6 of your Bid; CD's or Flash Drives submissions are also acceptable)

It is the responsibility of the Bidder/Contractor to ensure that all items and services proposed conform to all local, state and federal law concerning safety (e.g., OSHA and NOSHA) and environmental control (e.g., EPA and Clark County Pollution Regulations) and any other enacted ordinance, code, law or regulation. The Bidder/Contractor shall be responsible for all costs incurred for compliance with any such possible ordinance, code, law or regulation. No time extensions shall be granted or financial consideration given to the Contractor for time or monies lost due to violations of any such ordinance, code, law or regulations that may occur. Pursuant to the services to be provided the laws and safety regulations.

2.8.1 Personal Protection and Equipment (PPE):

Bidder/Contractor shall at its own expense, protect its employees and all other persons from risk of death, injury or bodily harm arising from or in any way related to the scope of work being performed for SNRHA, including emergencies. Bidder/Contractor shall fully comply with all laws, orders, citations, rules, regulations, standards and statutes concerning Occupational Health and Safety (OSHA) including a safety plan for accident prevention. The Service



Provider's Safety Plan must include the use of PPE; following all Federal/State OSHA and EPA regulations requirements for PPE related to your NV State/County License.

Bidder/Contractor shall prohibit/prevent the presence of the use of alcohol or drugs by its employees, subcontractors or suppliers at all SNRHA job site/locations. Immediate stop work is required by service provider if any such person is found to be under the influence of alcohol or drugs.

Bidder/Contractor is responsible to pay all fines or penalties assessed upon performance violations relating to the scope of work. Bidder/Contractor shall conduct inspections to determine that safe working conditions and equipment exist and safe practices are observed; and accepts sole responsibility for providing a safe place to work for its employees and the employees of all subcontractors.

Bidder/Contractor shall immediately notify SNRHA Property Manager and/or SNRHA's representative of any unsafe conditions or practices observed on the work site. Furthermore, contractor shall immediately contact the SNRHA Project Manager, Property Manager and Procurement Department of any accidents or injuries on the work site performed under this PO or Contract.

Bidder/Contractor must provide to their staff for all SNRHA projects, Material Safety Data Sheets (MSDS) which are maintained in a visible place or company vehicle for any hazardous material used in completion of the work performed for SNRHA.

Non-compliance to any OSHA and EPA regulations including PPE standards will result in termination of PO/Contract, in addition may include non-payment of services.

- 2.9 Bidder/Contractor/Subcontractors, Employee Background Checks:** To ensure the safety of SNRHA residents and staff, Bidder, Contractor, or Subcontractors are required to perform background check on all of their employees working on SNRHA property. SNRHA have the right to request the said background verifications during the course of the contract.
- 2.10 Occupancy of Development During Contract Period:** If applicable, Bidder/Contractor is advised that if the development and/or service site will be occupied during the entire time of the contract awarded pursuant to this RFQ – it is essential that basic consideration be taken into account in preparing for, scheduling, and carrying out the work under such contract awarded pursuant to this RFQ. The Bidder/Contractor and all subcontractors must bear in mind at all times that the work must be carried out expeditiously with all reasonable measure to eliminate exposure to potential hazards and minimal disruption to the lives and activities of the residents of the service site.



2.11 Discrepancies in Specifications and Designs: Bidder/Contractor must carefully read the specifications, examine the designs and details, and inspect the entire site for existing conditions prior to submitting bid. Errors, Omissions, and conflicts must be reported to SNRHA for interpretation, special instructions, or addendum.

2.11.1 If there are any discrepancies in the Designs or the document deemed to be the best practice or item by SNRHA shall govern. If Bidder/Contractor identifies such discrepancy in connection with preparing its bid, Bidder/Contractor shall seek and acquire written clarification from SNRHA per the guidelines as identified in the solicitation. Any bid submitted without such clarification shall be interpreted in favor of the SNRHA, and Bidder accepts full responsibility for its failure to identify and reconcile such discrepancy prior to submitting its bid.

2.12 Responsibilities:

2.12.1 Contractor shall be responsible for removing any debris from the development related to the Bidder's activities performed in connection with any contract awarded pursuant to the solicitation in any unsecured area at the end of each workday. Bidder shall repair and/or replace any property damaged in any secured area during period of work. Bidder shall ensure that all work performed by the Bidder, or their subcontractors, is done in a professional manner and in compliance with all codes, laws, regulations, and industry standards.

2.12.2 Permit & Licenses: Bidder/Contractor is responsible for obtaining all permits and licenses as it relates to the Scope of Work for this solicitation. Bidder must be a duly licensed contractor in the State of Nevada for the category of work identified in the Scope of Work. Bidder must also be licensed to do business in governing jurisdictions.

2.13 Technical Specifications and Scope of Work: See Attachment H for complete Scope of Work

Provide all necessary labor and material to equipment for the rehabilitation of wind damaged unit at 802 McWilliams, LV, NV 89106 as stated within Section 2.2 above. Finished repairs must be free of all defects.

3.0 SOLICITATION PROCEDURES & SUBMISSION INSTRUCTIONS: (Refer to Attachment C, HUD 5369 Instructions to Bidders for more details). Award will be made to the most responsive, responsible, lowest General Contractor (bidder) that meet all requirements of the conditions and Form of Bid, General Requirements and Contract requirements for all locations and work.

3.1 Pre-Bid Conference and Site Visits:

Pre-Bid Conference: **Thurs., March 28, 2024, 9:00 AM (PST), 802 McWilliams, LV, NV**

**Site Visit: Thurs, March., 28, 2024, 9:00AM, following Bid Conference:
9:30 AM: 802 McWilliams, Las Vegas, NV 89106**

All prospective bidders must attend. The purpose is to site-verify the scope of work and review bid submission requirements and to address prospective bidders' initial questions and concerns.

3.2 Question & Answer Period: All questions and requests for interpretation must be provided type-written and in writing by **April., 11, 2024, by 10:00 AM (PST)**. Questions will not be responded to after the deadline. All questions must be emailed to: **Ryan J. Perry,**
<https://nevada.ionwave.net/HomePage.aspx>



3.3 Bid Submission Deadline and Public Bid Opening:

3.3.1 Bid Submission Deadline: Thursday., April., 25, 2024 at 10:00 AM (PST); Two (2) Sealed, hard copy bids (provided in a sealed envelope or box) are to be submitted to SNRHA Procurement & Contracts Office, 340 N. 11th Street, Suite 180, Las Vegas, NV 89101.

Electronic pricing must be input at <https://nevada.ionwave.net/HomePage.aspx> for each Property. The total of the property must equal to the total amount noted on the Bid Form in Tab 3 of your Bid Submittal. **Your bid will be deemed non-responsive without both 2 sealed, hard-copy bids (one marked original and one marked copy, with corresponding tabs) and your electronic submission.**

3.3.2 No Public Bid Opening: Bid Results will be posted on the noted websites in the form of an Addendum.

3.4 Bid Guarantee and Bid Bond: Applicable to all construction and equipment contracts: 5% Bid Guarantee must be submitted with the Bid Submittal under Tab 4. Bids submitted without at least **5% Bid Guarantee** of the amount of the total Bid, shall be considered non-responsive and not considered for award of contract. **The Bid Guarantee may be in the form of a cashier's check payable to the SNRHA or U.S. Government Bonds at par value or a Bid Bond secured by a surety company acceptable to the U.S. Government** and authorized to do business in the state where the work is performed. Refer to HUD 5369 Form, Instructions to Bidders, page 3, Section 8, (attached).

Also, be advised that upon award, a **100% Payment and Performance Bond equal to the amount of the bid is required, which guarantees the work, if bid is \$100K or more.**

3.5 Bid Submittal Format: In order that the SNRHA can properly evaluate the offers received, all bids submitted in response to this solicitation must be formatted in accordance with the noted sequence. Each category must be separated by numbered index dividers and labeled with the corresponding Tab as referenced below. It is preferred and recommended that the Bidder use an appropriate sized 3 ring binder that if necessary, the information can be removed and returned to the binder in its original condition.

3.5.1 Tabbed Bid Submittal: The RFQ including attachments is the entire package of information necessary for potential bidders to submit a bid. The RFQ includes a description of the services or services being purchased, any unique technical information, time and place of bid opening, time and place of site inspections or Pre-Bid Conference, a form for stating the bid price and any required forms, as outlined below:

3.5.1.1 Tab No. 1: Bid Submission and Format Checklist: (Attachment A to this Solicitation) This 2-page form must be fully completed, executed where provided and submitted under this Tab as a part of your Bid submittal. It is recommended that it be used as a guide to ensure all required documents are included in your Bid Submittal.

3.5.1.2 Tab No. 2: Disclosure of Ownership Form: (Attachment B) This form must be completed and returned under this Tab as part of your Bid submittal for all **Prime and Subcontractors.**

Conflict of Interest Form: (Attachment B) This form must be completed and returned under this Tab as part of your Bid submittal for all **Prime and Subcontractors**



Statement of Bidders Qualifications Form (General Contractor):

(Attachment B) This form must be completed and returned under this Tab as part of your Bid submittal.

- 3.5.1.3 Tab No. 3: Bid Form and HUD Form 51000 Schedule of Amounts for Contract Payments (Attachment B):** These documents must be fully completed, executed and submitted under this Tab as part of your Bid Submittal. HUD Form 51000 must be included for the service site.
- 3.5.1.4 Tab No. 4: 5% Bid Guarantee or Bid Bond (Attachment B)** Must be submitted with the Bid submittal under this Tab. Bid submittal provided without the Bid Guarantee or Bid Bond shall be considered Non-Responsive and not considered for award of contract. Refer to HUD 5369 Instructions to Bidders, page 3, Section 8.
- 3.5.1.5 Tab No. 5: Required HUD & SNRHA Forms:** The following forms are attached as Attachment C to this IFB Document and must be utilized and/or executed and returned under this Tab:
- 3.5.1.5.1 HUD Form 5369-A, Representations, Certifications and Other Statement of Bidders;** (Complete and Return under this Tab)
 - 3.5.1.5.2 Subcontractor's List:** This form must be fully completed with addresses of subcontractors at the time of bid. **Subcontractors who are not submitted at the time of Bid, will not be considered for approval.** (Complete and Return under this Tab)
 - 3.5.1.5.3 Subcontractor Affirmative Action Form:** This form must include each trade used. (Complete and return under this Tab)
 - 3.5.1.5.4 Suggested Affirmative Action Plan for Utilization Area Businesses:** (Complete and return under this Tab)
 - 3.5.1.5.5 SNRHA Drug-Free Workplace Certification,** (Complete and return under this Tab)
 - 3.5.1.5.6 Authorization to Release Information,** (Complete and return under this Tab)
 - 3.5.1.5.7 Non-Collusive Affidavit Certification,** (Complete, Notarize and return under this Tab)
- 3.5.1.6 Tab No. 6: Managerial Capacity/Financial Viability:** The Bidder's entity must submit under this tab a concise description of its managerial and financial capacity to deliver the proposed services, including financial statement, brief resumes for the persons identified within Attachment B, SNRHA Disclosure of Ownership Form. Such information shall include the bidder's qualifications to provide the services; a description of the background and current organization of the institution, including a current organizational chart.

References: The Bidder shall submit a listing of former or current references, including Public Housing Agencies, for whom similar or like services have been performed. The listing shall include:



- 3.5.1.6.1 The client's name,
- 3.5.1.6.2 The client's address,
- 3.5.1.6.3 The client's telephone number, and
- 3.5.1.6.4 A brief description and scope of services provided including the dates the services were provided.

3.5.1.7 **Tab No. 7: SNRHA's Section 3 Clause and Contractor Initial Response Form:** (Attachment E) The SNRHA is required by HUD to implement its Section 3 Plan to the greatest extent feasible for any new contracts that has a labor component for employment opportunities for small businesses and low-income resident/persons as it is subject to the terms and conditions under Section 3 of the HUD Act of 1968, as amended, 12. U.S.C 1701u. Please acknowledge acceptance and receipt by signature and return of the Section 3 Clause and Contractor Initial Response.

3.5.1.8 **Tab No. 8: Equal Employment Opportunity Policy (EEO):** (Attachment F) The Bidder must provide a copy of its EEO Policy and a brief description of the positive steps it will take to ensure compliance, to the greatest extent feasible.

3.5.1.9 **Tab No. 9: Section 3 Business Preference (Optional Item):** (Attachment G) For any Bidder claiming a Section 3 Business Preference, he/she shall include the fully completed and executed Section 3 Business Preference Certification Form and any other documentation required by that form under this Tab. If the Bidder does not claim a Section 3 Preference, please note under this Tab a statement that reads, NO SECTION 3 BUSINESS PREFERENCE BEING CLAIMED". **Note: Registering on the HUD Section 3 Business database does not qualify you as a Section 3 Business or provide you with a Section 3 Business Certification.**

3.5.1.10 **Tab No. 10: Joint Venture Information (Optional Item):** The Bidder shall identify hereunder whether or not he/she intends to submit a Bid as a Joint Venture with another entity. The Bidder should provide proof of filing with the State and any and all applicable agencies of the joint venture and all required documentation forming this venture. This Document must be fully completed, executed and submitted under this Tab as part of your Bid Submittal.

Note: Please remember that all information required from the Bidder under the proceeding tabs must also be included for any joint venture.

3.5.1.11 **Tab No. 11: Other Information (Optional Item):** The Bidder may include under this tab any other general information he/she deem necessary.

If No Information Submitted: If no information is to be placed under any of the Tabs (especially the Optional Tabs), please place a statement such as 'NO INFORMATION IS BEING PLACED UNDER THIS TAB" or "THIS TAB LEFT INTENTIONALLY BLANK". Do not eliminate any of the Tabs.

3.6 Bidder/Contractor shall be responsible for submitting regular reports detailing their compliance with the conditions of the contract awarded in the format prescribed by, and at the intervals required by, SNRHA. These include, but are not limited to, payroll reports, certifications, and other various forms required by HUD.



3.7 Labor Standards – Davis-Bacon and Related Acts -This project is subject to the attached Davis Bacon Wage Decision: *Only applies to construction project over \$2,000.* All other labor rates are in accordance with State of Nevada Labor Laws.

3.7.1 Labor Rate:

Work to be performed is subject to Davis-Bacon wage requirements for all contracts where the construction is estimated to be over \$2,000. All laborers and mechanics employed under this contract as a result of this solicitation will be paid unconditionally and not less often than once a week at minimum labor rate established in the Davis Bacon Wage Decision noted below.

3.7.2 The construction activity for this scope of work may require additional labor classifications not reflected in the approved wage decision, i.e., painter, plumber, etc. Therefore, enclosed is HUD-4230-A, Report of Additional Classification and Rate.

3.7.3 Certified Payroll/Weekly Certified Payroll Form WH-37: must be submitted during the term of this contract. All laborers and mechanics employed under this contract in the construction or development of the project(s) involved will be paid unconditionally and not less often than once a week;

3.7.4 Contractor shall maintain daily and weekly records as to the employees/workers performing work on this project. Additionally, upon request, Contractor shall provide to SNRHA's Davis Bacon Specialist, Irma Solis, isolis@sivrha.org, after execution of contract.

3.7.4.1 List of Employee

3.7.4.2 Job Title

3.7.4.3 Description of Work Duties

Note: At any time during the term of this contract employees are removed or replaced; SNRHA shall be notified promptly of the change and provide the required information for the new employee.

4.0 CONTRACT EVALUATION AND AWARD:

The SNRHA intends to retain the successful bidder based on the lowest bidder being responsive and responsible (24CFR 85.36(b)(8)). To be considered responsive, a bid must conform to the material requirements of the solicitation. The Contracting Officer must examine the low bid to be sure that the bidder did not alter the specifications or other terms and conditions (e.g., delivery schedules, payment terms, etc.) or attempt to impose different terms and conditions. After determining the responsiveness of the low bid, the Contracting Officer shall determine if the bidder is responsible. Have adequate financial resources to perform the contract, or the ability to obtain them; Have the necessary organization, experience, accounting and operational controls, and technical skills, or the ability to obtain them; Have the necessary production, construction, and technical equipment and facilities, or the ability to obtain them; Be able to comply with the required or proposed delivery or performance schedule, taking into consideration all the bidder's/offeror's existing commercial and governmental business commitments; Have a satisfactory performance record; Be otherwise qualified and eligible to receive an award under applicable laws and regulations, including not be suspended, debarred or under a HUD-imposed LDP and System for Award Management.



4.1 License and Insurance Requirements: The successful Bidder/Contractor shall possess all of the required state and local contractors' licenses, and certifications required to perform work of the type required by this solicitation in the State of Nevada, County of Clark and provide copies to SNRHA. The following are the required insurance certificates and/or limits:

- 4.1.1 Certificate of Insurance per these specifications to be provided upon award of contract.
- 4.1.2 Policy of General Liability insurance, with a minimum coverage of \$1,000,000 per occurrence and a minimum of \$2,000,000 aggregate, together with damage to premises and fire damage of \$50,000 and medical expenses for anyone person of \$5,000, with a deductible of not greater than \$1,000. The SNRHA shall be named upon the certificate as an "additional insured," together with providing a copy of the corresponding endorsement evidencing the same.
- 4.1.3 Evidence of Automobile Liability insurance, with a combined single limit of \$1,000,000 or for every vehicle utilized during the term of this contract, when not owned by the entity, each vehicle must have evidence of automobile insurance coverage with limits of no less than of \$50,000 per occurrence, \$100,000 aggregate and medical coverage of at least \$5,000; and
- 4.1.4 Appropriate worker's compensation coverage. (Not applicable if entity consists of only one employee).
- 4.1.5 Failure to maintain the above-reference insurance coverage, including naming the SNRHA as an additional insured (where appropriate) during the term(s) of this contract shall constitute a material breach thereof.
- 4.1.6 Certificate Holder's Information shall be addressed as follows and delivered via US postage-paid mail to:

Southern Nevada Regional Housing Authority
Attn: Procurement & Contracts Office
Post Office Box 1897
Las Vegas, NV 89125

or emailed to or emailed to: rperry@snvrha.org

5.0 CONTRACT SERVICE STANDARDS: All work performed pursuant to this solicitation must confirm and comply with all applicable local, state and federal laws.

6.0 ATTACHMENTS: Recap of Section 3.5

- 6.1 **ATTACHMENT A: Bid Submission and Format Checklist Form** (use as a guide, return under Tab 1 of your Bid).
- 6.2 **ATTACHMENT B:**
 - 6.2.1 **Disclosure of Ownership Form**, (Return under Tab 2 of your Bid);
 - 6.2.2 **Disclosure of Conflict of Interest Form**, (Return under Tab 2 of your Bid);
 - 6.2.3 **Statement of Bidders Qualifications Form**, (Return under Tab 2 of your Bid);
 - 6.2.4 **Bid Form**, (Return under Tab 3 of your Bid);
 - 6.2.5 **HUD Form 51000, Schedule of Amounts of Contract Payments** (one for each service site for a total of 1; must equal to the total Bid amount on Bid Form)



- 6.2.6 **Bid Guarantee or Bid Bond**, (Return 5% of Total Bid Amount under Tab 4 of your Bid, in the form of Cashier's Check made payable to the Southern Nevada Regional Housing Authority or Security Bond with raised seal)

- 6.3 **ATTACHMENT C: HUD & SNRHA REQUIRED FORMS:**
 - 6.3.1 **HUD Form 5369, Instructions to Bidders for Contracts and Indian Housing Programs**, (Keep for your information);
 - 6.3.2 **HUD Form 5369A, Representations, Certifications and other Statement of Bidders**, (Return under Tab 5 of your Bid);
 - 6.3.3 **HUD Form 5370, General Conditions for Construction Contracts** (Keep for your information)
 - 6.3.4 **HUD Bulletin 90-23**, (Keep for your information);
 - 6.3.5 **Davis Bacon Residential Wages General Decision, Certified Payroll and Employee List**, (Keep for your information; will be required after award);
 - 6.3.6 **Subcontractor's List**, (Return under Tab 5 of your Bid);
 - 6.3.7 **Subcontractor Affirmative Action Form** (Return under Tab 5 of your Bid);
 - 6.3.8 **Suggested Affirmative Action Plan for Utilization Area Businesses** (Return under Tab 5 of your Bid)
 - 6.3.9 **SNRHA Drug-Free Workplace Certification** (Return under Tab 5 of your Bid);
 - 6.3.10 **Non-Collusive Affidavit Certification** (Return under Tab 5 of your Bid);
 - 6.3.11 **Authorization to Release Information** (Return under Tab 5 of your Bid);
 - 6.3.12 **SNRHA Sample Contract & Insurance Certificate** (Keep for your information)

- 6.4 **ATTACHMENT D:** SNRHA's Section 3 Clause and Contractor Initial Response Form (Return under Tab 7 of your Bid)

- 6.5 **ATTACHMENT E:** Equal Employment Opportunity Policy, (Return under Tab 8 of your Bid)

- 6.6 **ATTACHMENT F:** Section 3 Business Preference (Optional Submission), if claiming preference, complete and return under Tab 9 of your Bid, with certification)

- 6.7 **ATTACHMENT G:** Additional Clauses, (Keep for your information); and

- 6.8 **ATTACHMENT H:** Scope of Work and all supporting documents (Keep for your information) including frequently asked questions regarding these services.



ATTACHMENT A

BID SUBMISSION FORMAT CHECKLIST



BID SUBMISSION AND FORMAT CHECKLIST

Page 1 of 2

IMPORTANT: Each bidder **must submit two (2) hard-copy bid submittals, (1 original and 1 copy marked "Copy")** sealed in an envelope or box to include company name, address, solicitation number and name of services. The SNRHA will not accept your package if it's unsealed. It is recommended that submittals are provided in binders with numbered tabs that extend out from the sides of the pages. Bidders are also required to sign and date and return any and all applicable forms as requested within this Solicitation. Please use this form as a guide by marking an "X" where provided to indicate that the information has been included within your hard-copy bid submittal. Also complete the Section 3 Statement and the Bidder's Statement as noted below.

COMPANY NAME: _____

- ___ **TAB 1. The "Bid Submission and Format Checklist" Form (Attachment A)**

- ___ **TAB 2. The "Disclosure of Ownership" Form (Contractors and Subs) (Attachment B)**
___ **The "Disclosure of Conflict of Interest Form**
___ **Statement of Bidders Qualifications Form (Attachment B)**
___ **IRS W9 Request for Taxpayers Identification Number (Attachment B)**

- ___ **TAB 3. The "Bid Form" signed with written amount and dollar figure (Attachment B)**
___ **HUD Form 51000, Schedule of Amounts of Contract Payments, (Attachment B)**
Note: Provide one HUD Form 51000 for each property and Bid cost must be entered at <https://nevada.ionwave.net/HomePage.aspx> and **MUST** equal the total amount indicated on Bid Form

- ___ **TAB 4. The "Bid Guarantee" or "Bid Bond" (Attachment B)**
Note: 5% of total bid amount is required with your bid submittal

- ___ **TAB 5. REQUIRED HUD & SNRHA FORMS: (Attachment C)**
___ **HUD Form 5369A, Representations, Certifications and Other Statement of Bidders**
___ **Subcontractor's List, complete list with addresses ONLY at time of Bid for approval**
___ **Subcontractor Affirmative Action Form**
___ **Suggested Affirmative Action Plan for Utilization Area Businesses**
___ **SNRHA Drug-Free Workplace Certification**
___ **Non-Collusive Affidavit Certification**
___ **Authorization to Release Information**

- ___ **TAB 6. Managerial Capacity/Financial Viability, include brief resumes'**
___ **References**
___ **Safety and Training Plan, pursuant to OSHA and EPA Regulations (CD or flash drive)**

- ___ **TAB 7. SNRHA's Section 3 Clause and Contractor Initial Response Form (Attachment D)**

- ___ **TAB 8. Equal Employment Opportunity Policy (Attachment E)**

- ___ **TAB 9. Section 3 Business Preference, (Optional Item), must include Certification, (Attachment F)**

- ___ **TAB 10. Subcontractor/Joint Venture Information, (Optional Item)**

- ___ **TAB 11. Other Information You Deem Necessary That the SNRHA Should Know**



BID SUBMISSION FORMAT CHECK LIST
PAGE 2 OF 2

SECTION 3 STATEMENT

Are you claiming a Section 3 Business Preference? YES___or NO___. If "YES", pursuant to the Section 3 portion within the Conditions and Specifications, and pursuant to the documentation justifying such submitted under Tab No. 9, which priority are you claiming? _____

BIDDER'S STATEMENT

The undersigned Bidder/Contractor hereby states that by completing and submitting this Form and all other documents within this Bid submittal, he/she is verifying that all information provided herein is, to the best of his/her knowledge, true and accurate, and that if the HA discovers that any information entered herein to be false, such shall entitle the HA to not consider or make award or to cancel any award with the undersigned party. Further, by completing and submitting the Bid submittal, and by entering and submitting the costs where provided within the noted website, the undersigned Bidder/Contractor is thereby agreeing to abide by all terms and conditions pertaining to this solicitation as issued by the HA, either in hard copy or on the noted website, including an agreement to execute the attached sample contract form. Pursuant to all solicitation documents, this Form of Bid and all attachments and pursuant to all completed documents submitted, the undersigned proposes to supply the HA with the services described herein for the fee(s) entered within the areas provided within this solicitation and your bid.

SIGNATURE

DATE

PRINTED NAME

COMPANY NAME



ATTACHMENT B

REQUIRED SNRHA FORMS

1. SNRHA Disclosure of Ownership Form
2. SNRHA Disclosure of Conflict of Interest Form
3. Statement of Bidders Qualifications Form
4. Bid Form (total for entire project)
5. HUD Form 51000, Schedule of Amounts of Contract Payments
Note: Provide 1 HUD Form 51000 for each site, for a total of 1
6. Bid Guarantee or Bid Bond (5% of total bid amount is due at time of Bid submission)



DISCLOSURE OF OWNERSHIP

INSTRUCTIONS: This form must be completed by the General/Prime Contractor, each Sub-contractor and Joint Venture Partnerships. Please provide copies of all Business Licenses, Articles of Incorporation, etc., and WBE, MBE Section 3, RBE Certifications with this form.

* REQUIRED FIELDS

*Company Name, *Address, *City, State & Zip, *Telephone, Fax, *Primary Contact, *Title, *Email Address, *Federal Tax Identification Number, DUNS #, *Business License Number, State of Nevada Contractor's License Number, If any

NAME AND TITLE OF PRINCIPALS OF YOUR COMPANY WHO ARE AUTHORIZED TO SIGN ON COMPANY'S BEHALF Please list additional principals on a separate sheet of paper.

*Name, *Title, % Owned (repeated for multiple principals)

*SUPPLIER DIVERSITY STATEMENT: IF YOU DO NOT COMPLETE THIS AREA, WE CANNOT ADD YOUR FIRM TO OUR ELIGIBLE LIST. SNRHA receives federal funding; we MUST report to the government our supplier diversity efforts. This Information is used for coding and reporting purposes only and will not affect the ability of your firm to do business with our agency. Resident (RBE) Minority (MBE) or Women-Owned (WBE) Business Enterprise qualifies by virtue of 51% or more of the ownership and active management by one or more of the following (check all that apply):

Male Owned, Woman Owned, Asian/Pacific, African American, 3/RBE Certification #, Business Certification #, Public Held Corporation, Caucasian American, Hasidic Jew, Veteran, Disabled, Government Agency, Native American, Asian/Indian, W/MBE Certification#, Non-Profit Organization, Hispanic American, SNRHA Resident, HUBZONE Certification #, Emerging Small Business (ESB) Tier 1, Tier 2

*DOES YOUR COMPANY RECEIVE A 1099? YES or NO
*ARE YOU REGISTERED WITH SYSTEM FOR AWARD MANAGEMENT (SAM): YES or NO If no, please visit www.SAM.GOV to register.
*ARE YOU REGISTERED WITH EMERGING SMALL BUSINESS PROGRAM: YES or NO If Yes, please note Tier above. If No, doing so may prove increased business opportunities for your company. Contact Nathan Jackson at www.diversifynevada.com or esbprogram@diversifynevada.com

*DEBARRED STATEMENT: Has this firm or any principles ever been disbarred from providing any items or services by any local, state or federal governmental agency? YES or NO If yes, please attach a full detailed explanation, including dates, circumstances and current status.

*DISCLOSURE STATEMENT: Does/has this firm or any principal have/had any personal or professional relationship with any commissioner or officer of the SNRHA? YES or NO If yes, please attach a full detailed explanation, including dates, circumstances and current status.

The undersigned hereby affirms that he/she is empowered to sign this form and requests that the above-noted firm be added to the SNRHA's list of firms eligible to do business with the SNRHA. The undersigned further affirms that, to the best of his/her knowledge, the above information is current and accurate, and acknowledges on behalf of the noted firm that the non-response of two (2) consecutive invitations to provide quotes/bids/proposals by the SNRHA will give the SNRHA the right to remove that firm from its list of eligible firms.

INSURANCE: Copy of insurance certificate must be provided immediately upon Notice of Award of contract, naming the SNRHA as the Certificate Holder and as an additional insured regarding General Liability.

General Liability Insurance Policy # and Carrier:
Workman's Compensation Policy # and Carrier:
Automobile Liability Insurance Policy # and Carrier:

Signature, Date, Printed Name



DISCLOSURE OF CONFLICT OF INTEREST

(Page 1 of 2)

**TO BE REVIEWED AND RESPONDED TO, WHETHER OR NOT APPARENT OR REAL CONFLICT(S) EXIST.
THIS FORM MUST BE SIGNED AND DATED BY ENTITY'S REPRESENTATIVE AND PLACED UNDER TAB 2 ALONG WITH
THE DISCLOSURE OF OWNERSHIP FORM**

- 1.0** Ethics in Public Contracting: Ethical standards apply not only to PHA employees and Contracting Officers but to others with a vested interest in PHA contracts such as members of the Board of Commissioners, other officials and agents of the authority, and contractors with whom the PHA does business. Please refer to Handbook No. 7460.8 Rev 2, Chapter 4, which explains the specific ethical requirements for PHA contracting 24 CFR 85.36 (b)(3).
- 1.1** Principles: Members of the Board of Commissioners, PHA employees, and any others serving in an official position or acting as an agent of the PHA (hereafter referred to as employees, officers, or agents) must discharge their duties impartially to ensure fair competitive access to procurement opportunities by responsible contractors. Moreover, employees, officers, and agents should conduct themselves in such a manner as to foster the public's confidence in the integrity of the PHA procurement organization and process. Any attempt to realize personal gain through PHA employment or to serve as an officer or agent of the PHA through actions inconsistent with the proper discharge of duties is a breach of public trust.
- 1.2** Conflicts of Interest (24 CFR 85.36(b)(3) and Section 19 of the Annual Contribution Contract (ACC) between HUD and Public Housing. PHAs must observe the following conflict of interest prohibitions:
 - 1.2.1** No PHA employee, officer, or agent shall participate in the selection, award or administration of a contract supported by Federal funds if a conflict of interest, financial or otherwise, real or apparent, would be involved. Such a conflict would arise when the employee, officer or agent, any member of his or her immediate family; his or her partner; or an organization which employs or is about to employ any of the above, has a financial or other interest in the firm selected for the award.
 - 1.2.2** Immediate family is defined as: father, mother, sister, brother, son, daughter, wife, husband, grandparents, stepparents, in-law, sister-in-law, son-in-law, daughter-in-law, uncle and aunt and legal guardian and legal ward. Uncle and Aunt shall be defined as brother and sister of your biological father or mother.
 - 1.2.3** In addition to any other applicable conflict of interest requirements, neither the PHA nor any of its contractors or their subcontractors may enter into any contract, subcontract, or arrangement in connection with a project under the ACC in which any of the following classes of people have an interest, direct or indirect, during his or her tenure or for one year thereafter:
 - 1.2.3.1** Any present or former member or officer of the governing body of the PHA, or any member of the officer's immediate family. There shall be excepted from this prohibition any present or former tenant commissioner who does not serve on the governing body of a resident corporation, and who otherwise does not occupy a policymaking position with the resident corporation, the PHA or a business entity.
 - 1.2.4** Any employee of the PHA who formulates policy or who influences decisions with respect to the project(s), or any member of the employee's immediate family, or the employee's partner.



DISCLOSURE OF CONFLICT OF INTEREST

(Page 2 of 2)

- 1.2.5** Any public official, member of the local governing body, or State or local legislator, or any member of such individuals' immediate family, who exercises functions or responsibilities with respect to the project(s) of the PHA. (Note: For additional important provisions see Section 19 of the ACC)
- 1.2.6** No present or former PHA employee, officer, or agent shall engage in selling or attempting to sell supplies, services, or construction to the PHA for one year following the date such employment ceased (see Sections 515 of the old ACC, form HUD-53011, dated 11/69, and Section 19 of the new ACC, form HUD-53012A, dated 7/95). The term "sell" means signing a bid or proposal, negotiating a contract, contacting any PHA employee, officer, or agent for the purpose of obtaining, negotiating, or discussing changes in specifications, price, cost allowances, or other terms of a contract; settling contract disputes; or any other liaison activity with a view toward the ultimate consummation of a sale, although the actual contract is negotiated by another person.
- 1.3** The undersigned hereby confirms and attest that he/she is empowered to sign this form and further affirms that, to the best of his/her knowledge there is or is not an apparent Conflict of Interest.

NOTE: If there is a conflict of interest, Proposers/Bidders must provide this information to SNRHA during the Solicitation process. Failure to do so shall be grounds to consider the Solicitation non-responsive.

Please identify the Conflict of Interest below: (Add supplemental sheet if required)

PERSON NAME	TITLE	RELATIONSHIP
I certify that the above information is true.		
Name: <i>(print)</i>	Title:	
Signature:	Date:	



STATEMENT OF BIDDER'S QUALIFICATIONS (GENERAL CONTRACTOR)

Page 1 of 2

All questions must be answered and the data must be clear and comprehensive. This statement must be notarized. Attach additional pages if needed.

1. Name of bidder: _____
2. Name of Principals: _____
3. Names of authorized signatories: _____
4. Permanent main office address: _____

5. When organized?: _____
6. Where incorporated?: _____
7. How many years have you been engaged in the contracting business under your present name?: _____

8. Previous names of companies in which the principals listed above (#2) have engaged in the contracting business:

9. List all contracts on hand by name of contract and gross amount:

10. Have you ever defaulted on a contract? If so, where and why?:

11. Have you ever refused to sign a contract at your original bid? If yes, explain:



STATEMENT OF BIDDER'S QUALIFICATIONS (GENERAL CONTRACTOR)

Page 2 of 2

12. Names, background, experience and current workload of the principal members of your personnel, including the officer.

Name	Background	Years in Contracting	Current Workload

13. Furnish written evidence of amount and type of credit available.

14. Attach the most recent financial statement.

15. Will you, upon request, fill out a detailed Financial Statement and furnish any other information that may be required by the SNRHA? Yes No

16. The undersigned hereby authorizes and requests any person, firm or corporation to furnish any information requested by the SNRHA, in verification of the recitals comprising this Statement of Bidder's Qualifications.

Dated at _____, this _____ day of _____, 20____.
(place) (date) (month) (year)

(Name of Bidder)

State of (_____)

By: _____

County of (_____)

Title: _____

_____ being duly sworn, deposes and says he is _____
(Individual Signing Above) (Title)

of _____ and that the answers to the foregoing questions and all statements therein
(Name of Organization)

contained are true and correct.

Sworn before me this _____ day of _____, 20____.

My Commission Expires: _____
(Date)

Notary Public: _____



BID FORM

Page 1 of 2

Ladies and Gentlemen:

1. The undersigned, being familiar with the local conditions affecting the cost of the work, and with the specifications (including this Solicitation, Instructions to Bidders, the form of Bid Bond, the form of Non-Collusive Affidavit, the form of Contract, and the form of Performance and Payment Bond or Bonds, the General Conditions, the Special Conditions, Equal Employment Opportunity Requirements, the General Scope of Work, the Technical Specifications and Drawings) and Addenda, if any, thereto as prepared by the Southern Nevada Regional Housing Authority (SNRHA herein), and at the office of the architect, hereby proposes to complete the work in conjunction with the construction of **RFQ Q24008 – Rehabilitation of 802 McWilliams, LV, NV 89106** in accordance with the Contract Documents within the time set forth and at the prices set forth below:
2. **BID SUBMISSION LOCATION, DATE AND TIME: Procurement & Contracts Office of the Southern Nevada Regional Housing Authority, 340 N. 11th Street, Suite 180, Las Vegas, Nevada 89101 on Tues., April 16, 2024, 10:00 a.m. (PST) **LATE BIDS WILL NOT BE ACCEPTED****
3. **BASE PROPOSAL:** The bidder agrees to furnish all labor, materials, equipment and services to construct and complete the project as described and required by the herein above stated Document and any Addenda, in accordance therewith for **both properties in the sum of:**

BASE BID AMOUNT	\$
<hr/>	
(Please print the total bid amount in words)	

4. In submitting this bid, it is understood that the right is reserved by the SNRHA to reject any and all bids. If written notice of the acceptance of this bid is postage-paid mailed, emailed or delivered to the undersigned within (30) days after the opening thereof, or at any time thereafter before this bid is withdrawn, the undersigned agrees to execute and deliver within ten (10) days after the contract is presented to him for signature.
5. Security in the sum of _____ Dollars (\$ _____), in the form of _____ is submitted herewith in accordance with the Specifications.
6. The Bidder hereby acknowledges that a fully executed, notarized Non-Collusive Affidavit is included with this IFB which states they have not entered into collusion with any person in respect to this Bid or any other Bid submission for the contract with the SNRHA.
7. The bidder represents that he has (), has not (), participated in a previous contract or subcontract subject to the Equal Opportunity clause prescribed by Executive Orders 10925, 11114 or 11246 or the Secretary of Labor; that he has (), has not (), filed all required compliance reports; and that representations indicating submission of required compliance reports, signed by proposed subcontractors, will be obtained prior to subcontract awards. (The above representation need not be submitted in connection with contracts or subcontracts, which are exempt from the clause.)



BID FORM

Page 2 of 2

8. **Certification of Non-segregated Facilities:** By signing this bid, the bidder certifies that he does not maintain or provide for his employees any segregated facilities at any of his establishments, and that he does not permit his employees to perform their services at any location, under his control, where segregated facilities are maintained. He certifies further that he will not maintain or provide for his employees any segregated facilities at any of his establishments, and that he will not permit his employees to perform their services at any location, under his control, where segregated facilities are maintained. The bidder agrees that a breach of this certification is a violation of the Equal Opportunity clause in this contract. As used in this certification, the term, "segregated facilities" means any waiting rooms, work areas, rest rooms and washrooms, restaurants and other eating areas, time clocks, locker rooms and other storage provided for employees which are segregated by explicit directive or are, in fact, segregated on the basis of race, color, religion, or national origin, because of habit, local custom, or otherwise. He further agrees that (except where he has obtained identical certifications from proposed subcontractors for specific time periods) he will obtain identical certifications from proposed subcontractors prior to the award of subcontract exceeding \$10,000.00 which are not exempt from the provisions of the Equal Opportunity clause; that he will retain such certifications in his files; and that he will forward a notice of his proposed subcontractors as provided in the SNRHA instruction to bidders.
9. **Right to Reject or Terminate:** The SNRHA reserves the right to reject any and all bids or to waive any informalities in the process. No bid submitted shall be withdrawn for a period of one hundred and twenty (120) days subsequent to the opening of proposals. without the express written consent of the SNRHA Procurement Manager. The SNRHA reserves the right to terminate the bid process or to terminate any award at any time for its convenience, or to cancel the award and make award to the next qualified bidder if the original successful bidder is not able to deliver the required services in a satisfactory manner within the terms outlined within the plans and specifications of these documents.

NOTE: THE PENALTY FOR MAKING FALSE STATEMENTS IN OFFERS IS PRESCRIBED IN 18 U.W.C. 1001.



THE FOLLOWING ADDENDA AND/OR _____ ARE HEREBY ACKNOWLEDGED AS BEING INCLUDED IN THIS BID (Failure to acknowledge may cause bid rejection):

Addendum #: _____ Date: _____

Addendum #: _____ Date: _____

Addendum #: _____ Date: _____

Other: _____ By: _____

(Print or type name of person signing above)

Title:

Name of person submitting bid

Date

Company Name

Phone Number

Address

Fax Number

City, State, Zip

Schedule of Amounts for Contract Payments

U.S. Department of Housing
and Urban Development
Office of Public and Indian Housing

OMB Approval No. 2577-0157

No progress payments shall be made to the contractor unless a schedule of amounts for contract payments in accordance with the construction contract is received.

Public reporting burden for this collection of information is estimated to average 1 hour per response, including the time for reviewing instructions, searching existing data sources, gathering and maintaining the data needed, and completing and reviewing the collection of information. This agency may not conduct or sponsor, and a person is not required to respond to, a collection of information unless that collection displays a valid OMB control number.

Construction practices and HUD administrative requirements establish the need that HAs maintain certain records or submit certain documents in conjunction with the oversight of the award of construction contracts for the construction of new low-income housing developments or modernization of existing developments. These forms are used by HAs to provide information on the construction progress schedule and schedule of amounts for contract payments. Responses to the collection of information are required to obtain a benefit or to retain a benefit. The information requested does not lend itself to confidentiality.

Project Name and Location 101 802 McWilliams, Las Vegas, NV 89106	RFQ Q24008
--	-------------------

Name, Address, and Zip Code of Contractor

Nature of Contract		Contract Number
Approved for Contractor by	Irlc	Date (mm/dd/yyyy)
Approved for Architect by	Ilik	Date (mm/dd/yyyy)
Approved for Owner by	IDa	Date (mm/dd/yyyy)

IBn Irb (1)	Description of Item (2)	Quantity (3)	Unit of Measure (4)	Unit Price in Place (5)	Amount of Sub-Item (6)	Amount of Principal Item (7)
	Labor					
	Materials					
	Equipment					
	Other					

Total Amount of Contract or Carried Forward	\$
--	----

To the best of my knowledge, all the information stated herein, as well as any information provided in the accompaniment herewith, true and accurate. **Warning:** HUD will prosecute false claims and statements. Conviction may result in criminal and/or civil penalties. (18 U.S.C. 1001, 1010, 1012; 31 U.S.C. 3729, 3802)

Signature of authorized representative	Date signed (mm/dd/yyyy)
--	--------------------------

Instructions for Preparation of form HUD-51000

1. A separate breakdown is required for each project and prime contract instructions for preparation are given below.
 - a. **Heading.** Enter all identifying information required for both forms.
 - b. **Columns 1 and 2.** In column 1, enter the item numbers starting with No. 1, and in column 2 enter each principal division of work incorporated in the contract work.
 - (1) **Master List.** The Master list contains the basic items into which any construction contract may be subdivided for the purpose of preparing the Construction Progress Schedule and the Periodical Estimates for Partial Payments. Only those items shall be selected which apply to the particular contract. To ensure uniformity, no change shall be made in the item numbers. Generally, about 25 to 40 major items appear in a contract.
 - (2) **Items Subdivided.** In the Contractor's breakdown, against which all periodical estimates will be checked prior to payment, each major item must be subdivided into sub-items pertinent to the project involved and in agreement with the Contractor's intended basis for requesting monthly payments.
 - c. **Column 3.** Enter the total quantity for each sub-item of each principal division of work listed in the breakdown.
 - d. **Column 4.** Enter the appropriate unit of measure for each sub-item of work opposite the quantities described in column 3, such as "sq. ft.," "yd.," "tons," "lb.," "lumber per M/BM," "brickwork per M," etc., applicable to the particular sub-item. Items shown on "lump sum" or equivalent basis will be paid for only on completion of the whole item and not on a percentage of completion basis.
 - e. **Column 5.** Enter the unit price, in place, of each sub-item of work.
 - f. **Column 6.** Enter the amount of each sub-item obtained by multiplying the quantities in column 3 by the corresponding unit prices in column 5.
 - g. **Column 7.** Enter the amount of principal item only, obtained by adding the amounts of all sub-items of each principal division of work listed in column 6. Continue with the breakdown on form HUD-51000.
 - h. The "Schedule of Amounts for Contract Payments" shall be signed and dated in the space provided at the bottom of each sheet of the form by the individual who prepared the breakdown for the Contractor.
2. The minimum number of copies required for each submission for approval is an original and two copies. When approved, one fully approved copy will be returned to the Contractor.



Master List of Items

Item No.	Division of Work	Item No.	Division of Work	Item No.	Division of Work
	Bond	20	Rough Carpentry		Site Improvements
	General Conditions \1	21	Metal Bucks	44	Retaining Walls
2 ¹	Demolition & Clearing	22	Caulking	45	Storm Sewers
	Structures	23	Weatherstripping	46	Sanitary Sewers
	General Excavation	24	Lath & Plastering-Drywall	47	Water Distribution System
	Footing Excavation	25	Stucco	48	Gas Distribution System
	Backfill	26	Finish Carpentry	49	Electrical Distribution System
	Foundation Piles & Caissons	27	Finish Hardware	50	Street & Yard Lighting Fire &
	Concrete Foundations	28	Glass & Glazing	51	Police Alarm System Fire
	Concrete Superstructures	29	Metal Doors	52	Protection System Street
	Reinforcing Steel	30	Metal Base & Trim	53	Work
	Waterproofing & Dampproofing	31	Toilet Partitions	54	Yard Work
2 ²	Spandrel Waterproofing	32	Floors	55	(Other)
	Structural Steel	33	Painting & Decorating	56	(Other)
	Masonry	34	Screens		Equipment
	Stonework	35	Plumbing	57	Shades & Drapery Rods
	Miscellaneous & Ornamental Metal	36	Heating	58	Ranges
1	Metal Windows	37	Ventilating System	59	Refrigerators
	Roofing	38	Electrical	60	Kitchen Cabinets & Work Tables
	Sheet Metal	39	Elevators	61	Laundry Equipment
		40	Elevator Enclosures—Metal	62	(Other)
		41	Incinerators—Masonry & Parts		
		42	(Other)	63	Punch List \2
		43	(Other)	64	Lawns & Planting

1 General Conditions should be 3% to 5% of contract amount.

2 Punch List should be approximately 1/2 of 1% or \$30 per dwelling unit, whichever is greater. Previous editions are obsolete



BID BOND

Page 1 of 3

KNOW ALL MEN BY THESE PRESENTS, that we the undersigned,

_____ as PRINCIPAL and
(Name of Principal)

_____ as SURETY, are held and firmly bound
(Name of Surety)

unto the Southern Nevada Regional Housing Authority, hereinafter called the "SNRHA," in the penal sum
of _____ Dollars, lawful money of the United States,
(Written Sum)

for the payment of which sum well and truly to be made, we bind ourselves, our heirs, executors,
administrators, successors and assigns, jointly and severally, firmly by these presents.

THE CONDITION OF THIS OBLIGATION IS SUCH that whereas the Principal has submitted the
accompanying bid, dated _____, 20__ for:

NOW THEREFORE, if the principal shall not withdraw said bid within the period specified therein after the opening of the same, or, if no period be specified within sixty (60) days after the said opening, and shall within the period specified therefore, or if no period be specified, within ten (10) days after the prescribed forms are presented to him for signature, enter into a written contract with SNRHA in accordance with the bids as accepted and give bond with good and sufficient surety or sureties, as required by the U. S. Treasury Circular No. 570, sureties acceptable to the government, for the faithful performance of and proper fulfillment of such contract; or in the event of the withdrawal of said bid within the period specified, or the failure to enter into such contract and given such bond within the amount specified in said bid and the amount for which SNRHA may procure the required work or supplies or both, if the latter amount be in excess of the former, the above obligation shall be void and of no effect, otherwise to remain in full force and virtue.



BID BOND

Page 2 of 3

IN WITNESS WHEREOF, the above-bounden parties have executed this instrument under their several seals this _____ day of _____, 20____, the name and corporate seal of each corporate party being hereto affixed and these presents duly signed by its undersigned representative pursuant to authority of its governing body.

ATTEST:

(Sole Proprietorship or Partnership)

(Individual Principal Signature)

(Business Address)

(Seal)

(Name of Individual Principal above)

OR ATTEST:

(Corporation)

(Corporate Principal Signature)

(Business Address)

(Name of Corporate Principal above)

(Title)

(Seal)



BID BOND

Page 3 of 3

ATTEST:

(Surety Company)

(Corporate Surety Signature)

(Corporate Surety Signature)

(Business Address)

By: _____

(Title)

(Seal)

(Power of Attorney for person signing Surety Company must be attached to the Bond)



ALTERNATE BID GUARANTEE

At the time of Bid Submission the following could be submitted in lieu of the Bid Bond; (All amounts being 5% of the Bid Price):

1. A certified check or bank draft made payable to the Southern Nevada Regional Housing Authority
2. A U.S. Government Bond in the amount made payable to the Southern Nevada Regional Housing Authority



ATTACHMENT C

REQUIRED HUD & SNRHA FORMS

1. HUD Form 5369, Instructions to Bidders For Contracts – Public and Indian Housing Programs (FYI)
2. HUD Form 5369A, Representations, Certifications and Other Statement of Bidders (RETURN UNDER TAB 5)
3. HUD Form 5370, General Conditions For Construction Contracts Public Housing Programs (FYI)
4. HUD Information Bulletin 90-23 (FYI)
5. Davis Bacon Residential Construction Wage General Decision, NV20240042, 1/5/2024 Certified Payroll Form with Sample, Employee List and HUD Form 4230A for Request of Additional Class & Rate (FYI AND TO BE PROVIDED TO THE SNRHA AFTER AWARD)
6. Subcontractor's List to include trades, addresses and telephone number (RETURN UNDER TAB 5)
7. Subcontractor's Affirmative Form (RETURN UNDER TAB 5)
8. Suggested Affirmative Action Plan for Utilization of Project Area Business (RETURN UNDER TAB 5)
9. SNRHA Drug-Free Workplace Certification (RETURN UNDER TAB 5)
10. Non-Collusive Affidavit Certification (RETURN UNDER TAB 5)
11. Authorization to Release Information (RETURN UNDER TAB 5)
12. SNRHA Sample Contract & Insurance Certificate (FYI)

**U.S. Department of Housing and
Urban Development**
Office of Public and Indian Housing

**Instructions to Bidders for Contracts
Public and Indian Housing Programs**

Instructions to Bidders for Contracts

Public and Indian Housing Programs

Table of Contents

Clause	Page
1. Bid Preparation and Submission	1
2. Explanations and Interpretations to Prospective Bidders	1
3. Amendments to Invitations for Bids	1
4. Responsibility of Prospective Contractor	1
5. Late Submissions, Modifications, and Withdrawal of Bids	1
6. Bid Opening	2
7. Service of Protest	2
8. Contract Award	2
9. Bid Guarantee	3
10. Assurance of Completion	3
11. Preconstruction Conference	3
12. Indian Preference Requirements	3

1. Bid Preparation and Submission

(a) Bidders are expected to examine the specifications, drawings, all instructions, and, if applicable, the construction site (see also the contract clause entitled **Site Investigation and Conditions Affecting the Work** of the General Conditions of the Contract for Construction). Failure to do so will be at the bidders' risk.

(b) All bids must be submitted on the forms provided by the Public Housing Agency/Indian Housing Authority (PHA/IHA). Bidders shall furnish all the information required by the solicitation. Bids must be signed and the bidder's name typed or printed on the bid sheet and each continuation sheet which requires the entry of information by the bidder. Erasures or other changes must be initialed by the person signing the bid. Bids signed by an agent shall be accompanied by evidence of that agent's authority. (Bidders should retain a copy of their bid for their records.)

(c) Bidders must submit as part of their bid a completed form HUD-5369-A, "Representations, Certifications, and Other Statements of Bidders."

(d) All bid documents shall be sealed in an envelope which shall be clearly marked with the words "Bid Documents," the Invitation for Bids (IFB) number, any project or other identifying number, the bidder's name, and the date and time for receipt of bids.

(e) If this solicitation requires bidding on all items, failure to do so will disqualify the bid. If bidding on all items is not required, bidders should insert the words "No Bid" in the space provided for any item on which no price is submitted.

(f) Unless expressly authorized elsewhere in this solicitation, alternate bids will not be considered.

(g) Unless expressly authorized elsewhere in this solicitation, bids submitted by telegraph or facsimile (fax) machines will not be considered.

(h) If the proposed contract is for a Mutual Help project (as described in 24 CFR Part 905, Subpart E) that involves Mutual Help contributions of work, material, or equipment, supplemental information regarding the bid advertisement is provided as an attachment to this solicitation.

2. Explanations and Interpretations to Prospective Bidders

(a) Any prospective bidder desiring an explanation or interpretation of the solicitation, specifications, drawings, etc., must request it at least 7 days before the scheduled time for bid opening. Requests may be oral or written. Oral requests must be confirmed in writing. The only oral clarifications that will be provided will be those clearly related to solicitation procedures, i.e., not substantive technical information. No other oral explanation or interpretation will be provided. Any information given a prospective bidder concerning this solicitation will be furnished promptly to all other prospective bidders as a written amendment to the solicitation, if that information is necessary in submitting bids, or if the lack of it would be prejudicial to other prospective bidders.

(b) Any information obtained by, or provided to, a bidder other than by formal amendment to the solicitation shall not constitute a change to the solicitation.

3. Amendments to Invitations for Bids

(a) If this solicitation is amended, then all terms and conditions which are not modified remain unchanged.

(b) Bidders shall acknowledge receipt of any amendment to this solicitation (1) by signing and returning the amendment, (2) by identifying the amendment number and date on the bid form, or (3) by letter, telegram, or facsimile, if those methods are authorized in the solicitation. The PHA/IHA must receive acknowledgement by the time and at the place specified for receipt of bids. Bids which fail to acknowledge the bidder's receipt of any amendment will result in the rejection of the bid if the amendment(s) contained information which substantively changed the PHA's/IHA's requirements.

(c) Amendments will be on file in the offices of the PHA/IHA and the Architect at least 7 days before bid opening.

4. Responsibility of Prospective Contractor

(a) The PHA/IHA will award contracts only to responsible prospective contractors who have the ability to perform successfully under the terms and conditions of the proposed contract. In determining the responsibility of a bidder, the PHA/IHA will consider such matters as the bidder's:

- (1) Integrity;
- (2) Compliance with public policy;
- (3) Record of past performance; and
- (4) Financial and technical resources (including construction and technical equipment).

(b) Before a bid is considered for award, the bidder may be requested by the PHA/IHA to submit a statement or other documentation regarding any of the items in paragraph (a) above. Failure by the bidder to provide such additional information shall render the bidder nonresponsible and ineligible for award.

5. Late Submissions, Modifications, and Withdrawal of Bids

(a) Any bid received at the place designated in the solicitation after the exact time specified for receipt will not be considered unless it is received before award is made and it:

(1) Was sent by registered or certified mail not later than the fifth calendar day before the date specified for receipt of offers (e.g., an offer submitted in response to a solicitation requiring receipt of offers by the 20th of the month must have been mailed by the 15th);

(2) Was sent by mail, or if authorized by the solicitation, was sent by telegram or via facsimile, and it is determined by the PHA/IHA that the late receipt was due solely to mishandling by the PHA/IHA after receipt at the PHA/IHA; or

(3) Was sent by U.S. Postal Service Express Mail Next Day Service - Post Office to Addressee, not later than 5:00 p.m. at the place of mailing two working days prior to the date specified for receipt of proposals. The term "working days" excludes weekends and observed holidays.

(b) Any modification or withdrawal of a bid is subject to the same conditions as in paragraph (a) of this provision.

(c) The only acceptable evidence to establish the date of mailing of a late bid, modification, or withdrawal sent either by registered or certified mail is the U.S. or Canadian Postal Service postmark both on the envelope or wrapper and on the original receipt from the U.S. or Canadian Postal Service. Both postmarks must show a legible date or the bid, modification, or withdrawal shall be processed as if mailed late. "Postmark" means a printed, stamped, or otherwise placed impression (exclusive of a postage meter machine impression) that is readily identifiable without further action as having been supplied and affixed by employees of the U.S. or Canadian Postal Service on the date of mailing. Therefore, bidders should request the postal clerk to place a hand cancellation bull's-eye postmark on both the receipt and the envelope or wrapper.

(d) The only acceptable evidence to establish the time of receipt at the PHA/IHA is the time/date stamp of PHA/IHA on the proposal wrapper or other documentary evidence of receipt maintained by the PHA/IHA.

(e) The only acceptable evidence to establish the date of mailing of a late bid, modification, or withdrawal sent by Express Mail Next Day Service-Post Office to Addressee is the date entered by the post office receiving clerk on the "Express Mail Next Day Service-Post Office to Addressee" label and the postmark on both the envelope or wrapper and on the original receipt from the U.S. Postal Service. "Postmark" has the same meaning as defined in paragraph (c) of this provision, excluding postmarks of the Canadian Postal Service. Therefore, bidders should request the postal clerk to place a legible hand cancellation bull's eye postmark on both the receipt and Failure by a bidder to acknowledge receipt of the envelope or wrapper.

(f) Notwithstanding paragraph (a) of this provision, a late modification of an otherwise successful bid that makes its terms more favorable to the PHA/IHA will be considered at any time it is received and may be accepted.

(g) Bids may be withdrawn by written notice, or if authorized by this solicitation, by telegram (including mailgram) or facsimile machine transmission received at any time before the exact time set for opening of bids; provided that written confirmation of telegraphic or facsimile withdrawals over the signature of the bidder is mailed and postmarked prior to the specified bid opening time. A bid may be withdrawn in person by a bidder or its authorized representative if, before the exact time set for opening of bids, the identity of the person requesting withdrawal is established and the person signs a receipt for the bid.

6. Bid Opening

All bids received by the date and time of receipt specified in the solicitation will be publicly opened and read. The time and place of opening will be as specified in the solicitation. Bidders and other interested persons may be present.

7. Service of Protest

(a) Definitions. As used in this provision:

"Interested party" means an actual or prospective bidder whose direct economic interest would be affected by the award of the contract.

"Protest" means a written objection by an interested party to this solicitation or to a proposed or actual award of a contract pursuant to this solicitation.

(b) Protests shall be served on the Contracting Officer by obtaining written and dated acknowledgement from —

Lewis Jordan, Executive Director
PO Box 1897
Las Vegas, NV 89127

[Contracting Officer designate the official or location where a protest may be served on the Contracting Officer]

(c) All protests shall be resolved in accordance with the PHA's/ IHA's protest policy and procedures, copies of which are maintained at the PHA/IHA.

8. Contract Award

(a) The PHA/IHA will evaluate bids in response to this solicitation without discussions and will award a contract to the responsible bidder whose bid, conforming to the solicitation, will be most advantageous to the PHA/IHA considering only price and any price-related factors specified in the solicitation.

(b) If the apparent low bid received in response to this solicitation exceeds the PHA's/IHA's available funding for the proposed contract work, the PHA/IHA may either accept separately priced items (see 8(e) below) or use the following procedure to determine contract award. The PHA/IHA shall apply in turn to each bid (proceeding in order from the apparent low bid to the high bid) each of the separately priced bid deductible items, if any, in their priority order set forth in this solicitation. If upon the application of the first deductible item to all initial bids, a new low bid is within the PHA's/IHA's available funding, then award shall be made to that bidder. If no bid is within the available funding amount, then the PHA/IHA shall apply the second deductible item. The PHA/IHA shall continue this process until an evaluated low bid, if any, is within the PHA's/IHA's available funding. If upon the application of all deductibles, no bid is within the PHA's/IHA's available funding, or if the solicitation does not request separately priced deductibles, the PHA/IHA shall follow its written policy and procedures in making any award under this solicitation.

(c) In the case of tie low bids, award shall be made in accordance with the PHA's/IHA's written policy and procedures.

(d) The PHA/IHA may reject any and all bids, except other than the lowest bid (e.g., the apparent low bid is unreasonably low), and waive informalities or minor irregularities in bids received, in accordance with the PHA's/IHA's written policy and procedures.

(e) Unless precluded elsewhere in the solicitation, the PHA/IHA may accept any item or combination of items bid.

(f) The PHA/IHA may reject any bid as nonresponsive if it is materially unbalanced as to the prices for the various items of work to be performed. A bid is materially unbalanced when it is based on prices significantly less than cost for some work and prices which are significantly overstated for other work.

(g) A written award shall be furnished to the successful bidder within the period for acceptance specified in the bid and shall result in a binding contract without further action by either party.

9. Bid Guarantee (applicable to construction and equipment contracts exceeding \$25,000)

All bids must be accompanied by a negotiable bid guarantee which shall not be less than five percent (5%) of the amount of the bid. The bid guarantee may be a certified check, bank draft, U.S. Government Bonds at par value, or a bid bond secured by a surety company acceptable to the U.S. Government and authorized to do business in the state where the work is to be performed. In the case where the work under the contract will be performed on an Indian reservation area, the bid guarantee may also be an irrevocable Letter of Credit (see provision 10, Assurance of Completion, below). Certified checks and bank drafts must be made payable to the order of the PHA/IHA. The bid guarantee shall insure the execution of the contract and the furnishing of a method of assurance of completion by the successful bidder as required by the solicitation. Failure to submit a bid guarantee with the bid shall result in the rejection of the bid. Bid guarantees submitted by unsuccessful bidders will be returned as soon as practicable after bid opening.

10. Assurance of Completion

(a) Unless otherwise provided in State law, the successful bidder shall furnish an assurance of completion prior to the execution of any contract under this solicitation. This assurance may be [Contracting Officer check applicable items] —

(1) a performance and payment bond in a penal sum of 100 percent of the contract price; or, as may be required or permitted by State law;

(2) separate performance and payment bonds, each for 50 percent or more of the contract price;

(3) a 20 percent cash escrow;

(4) a 25 percent irrevocable letter of credit; or,

(5) an irrevocable letter of credit for 10 percent of the total contract price with a monitoring and disbursements agreement with the IHA (applicable only to contracts awarded by an IHA under the Indian Housing Program).

(b) Bonds must be obtained from guarantee or surety companies acceptable to the U.S. Government and authorized to do business in the state where the work is to be performed. Individual sureties will not be considered. U.S. Treasury Circular Number 570, published annually in the Federal Register, lists companies approved to act as sureties on bonds securing Government contracts, the maximum underwriting limits on each contract bonded, and the States in which the company is licensed to do business. Use of companies listed in this circular is mandatory. Copies of the circular may be downloaded on the U.S. Department of Treasury website <http://www.fms.treas.gov/c570/index.html>, or ordered for a minimum fee by contacting the Government Printing Office at (202) 512-2168.

(c) Each bond shall clearly state the rate of premium and the total amount of premium charged. The current power of attorney for the person who signs for the surety company must be attached to the bond. The effective date of the power of attorney shall not precede the date of the bond. The effective date of the bond shall be on or after the execution date of the contract.

(d) Failure by the successful bidder to obtain the required assurance of completion within the time specified, or within such extended period as the PHA/IHA may grant based upon reasons determined adequate by the PHA/IHA, shall render the bidder ineligible for award. The PHA/IHA may then either award the contract to the next lowest responsible bidder or solicit new bids. The PHA/IHA may retain the ineligible bidder's bid guarantee.

11. Preconstruction Conference (applicable to construction contracts)

After award of a contract under this solicitation and prior to the start of work, the successful bidder will be required to attend a preconstruction conference with representatives of the PHA/IHA and its architect/engineer, and other interested parties convened by the PHA/IHA. The conference will serve to acquaint the participants with the general plan of the construction operation and all other requirements of the contract (e.g., Equal Employment Opportunity, Labor Standards). The PHA/IHA will provide the successful bidder with the date, time, and place of the conference.

12. Indian Preference Requirements (applicable only if this solicitation is for a contract to be performed on a project for an Indian Housing Authority)

(a) HUD has determined that the contract awarded under this solicitation is subject to the requirements of section 7(b) of the Indian Self-Determination and Education Assistance Act (25 U.S.C. 450e(b)). Section 7(b) requires that any contract or subcontract entered into for the benefit of Indians shall require that, to the greatest extent feasible

(1) Preferences and opportunities for training and employment (other than core crew positions; see paragraph (h) below) in connection with the administration of such contracts or subcontracts be given to qualified "Indians." The Act defines "Indians" to mean persons who are members of an Indian tribe and defines "Indian tribe" to mean any Indian tribe, band, nation, or other organized group or community, including any Alaska Native village or regional or village corporation as defined in or established pursuant to the Alaska Native Claims Settlement Act, which is recognized as eligible for the special programs and services provided by the United States to Indians because of their status as Indians; and,

(2) Preference in the award of contracts or subcontracts in connection with the administration of contracts be given to Indian organizations and to Indian-owned economic enterprises, as defined in section 3 of the Indian Financing Act of 1974 (25 U.S.C. 1452). That Act defines "economic enterprise" to mean any Indian-owned commercial, industrial, or business activity established or organized for the purpose of profit, except that the Indian ownership must constitute not less than 51 percent of the enterprise; "Indian organization" to mean the governing body of any Indian tribe or entity established or recognized by such governing body; "Indian" to mean any person who is a member of any tribe, band, group, pueblo, or community which is recognized by the Federal Government as eligible for services from the Bureau of Indian Affairs and any "Native" as defined in the Alaska Native Claims Settlement Act; and Indian "tribe" to mean any Indian tribe, band, group, pueblo, or community including Native villages and Native groups (including

corporations organized by Kenai, Juneau, Sitka, and Kodiak) as defined in the Alaska Native Claims Settlement Act, which is recognized by the Federal Government as eligible for services from the Bureau of Indian Affairs.

(b) (1) The successful Contractor under this solicitation shall comply with the requirements of this provision in awarding all subcontracts under the contract and in providing training and employment opportunities.

(2) A finding by the IHA that the contractor, either (i) awarded a subcontract without using the procedure required by the IHA, (ii) falsely represented that subcontracts would be awarded to Indian enterprises or organizations; or, (iii) failed to comply with the contractor's employment and training preference bid statement shall be grounds for termination of the contract or for the assessment of penalties or other remedies.

(c) If specified elsewhere in this solicitation, the IHA may restrict the solicitation to qualified Indian-owned enterprises and Indian organizations. If two or more (or a greater number as specified elsewhere in the solicitation) qualified Indian-owned enterprises or organizations submit responsive bids, award shall be made to the qualified enterprise or organization with the lowest responsive bid. If fewer than the minimum required number of qualified Indian-owned enterprises or organizations submit responsive bids, the IHA shall reject all bids and readvertise the solicitation in accordance with paragraph (d) below.

(d) If the IHA prefers not to restrict the solicitation as described in paragraph (c) above, or if after having restricted a solicitation an insufficient number of qualified Indian enterprises or organizations submit bids, the IHA may advertise for bids from non-Indian as well as Indian-owned enterprises and Indian organizations. Award shall be made to the qualified Indian enterprise or organization with the lowest responsive bid if that bid is -

(1) Within the maximum HUD-approved budget amount established for the specific project or activity for which bids are being solicited; and

(2) No more than the percentage specified in 24 CFR 905.175(c) higher than the total bid price of the lowest responsive bid from any qualified bidder. If no responsive bid by a qualified Indian-owned economic enterprise or organization is within the stated range of the total bid price of the lowest responsive bid from any qualified enterprise, award shall be made to the bidder with the lowest bid.

(e) Bidders seeking to qualify for preference in contracting or subcontracting shall submit proof of Indian ownership with their bids. Proof of Indian ownership shall include but not be limited to:

(1) Certification by a tribe or other evidence that the bidder is an Indian. The IHA shall accept the certification of a tribe that an individual is a member.

(2) Evidence such as stock ownership, structure, management, control, financing and salary or profit sharing arrangements of the enterprise.

(f) (1) All bidders must submit with their bids a statement describing how they will provide Indian preference in the award of subcontracts. The specific requirements of that statement and the factors to be used by the IHA in determining the statement's adequacy are included as an attachment to this solicitation. Any bid that fails to include the required statement shall be rejected as nonresponsive. The IHA may require that comparable statements be provided by subcontractors to the successful Contractor, and may require the Contractor to reject any bid or proposal by a subcontractor that fails to include the statement.

(2) Bidders and prospective subcontractors shall submit a certification (supported by credible evidence) to the IHA in any instance where the bidder or subcontractor believes it is infeasible to provide Indian preference in subcontracting. The acceptance or rejection by the IHA of the certification shall be final. Rejection shall disqualify the bid from further consideration.

(g) All bidders must submit with their bids a statement detailing their employment and training opportunities and their plans to provide preference to Indians in implementing the contract; and the number or percentage of Indians anticipated to be employed and trained. Comparable statements from all proposed subcontractors must be submitted. The criteria to be used by the IHA in determining the statement(s)'s adequacy are included as an attachment to this solicitation. Any bid that fails to include the required statement(s), or that includes a statement that does not meet minimum standards required by the IHA shall be rejected as nonresponsive.

(h) Core crew employees. A core crew employee is an individual who is a bona fide employee of the contractor at the time the bid is submitted; or an individual who was not employed by the bidder at the time the bid was submitted, but who is regularly employed by the bidder in a supervisory or other key skilled position when work is available. Bidders shall submit with their bids a list of all core crew employees.

(i) Preference in contracting, subcontracting, employment, and training shall apply not only on-site, on the reservation, or within the IHA's jurisdiction, but also to contracts with firms that operate outside these areas (e.g., employment in modular or manufactured housing construction facilities).

(j) Bidders should contact the IHA to determine if any additional local preference requirements are applicable to this solicitation.

(k) The IHA [] does [] does not [Contracting Officer check applicable box] maintain lists of Indian-owned economic enterprises and Indian organizations by specialty (e.g., plumbing, electrical, foundations), which are available to bidders to assist them in meeting their responsibility to provide preference in connection with the administration of contracts and subcontracts.

**U.S. Department of Housing
and Urban Development**
Office of Public and Indian Housing

**Representations, Certifications,
and Other Statements of Bidders**
Public and Indian Housing Programs

Representations, Certifications, and Other Statements of Bidders

Public and Indian Housing Programs

Table of Contents

Clause	Page
1. Certificate of Independent Price Determination	1
2. Contingent Fee Representation and Agreement	1
3. Certification and Disclosure Regarding Payments to Influence Certain Federal Transactions	1
4. Organizational Conflicts of Interest Certification	2
5. Bidder's Certification of Eligibility	2
6. Minimum Bid Acceptance Period	2
7. Small, Minority, Women-Owned Business Concern Representation	2
8. Indian-Owned Economic Enterprise and Indian Organization Representation	2
9. Certification of Eligibility Under the Davis-Bacon Act	3
10. Certification of Nonsegregated Facilities	3
11. Clean Air and Water Certification	3
12. Previous Participation Certificate	3
13. Bidder's Signature	3

1. Certificate of Independent Price Determination

(a) The bidder certifies that--

(1) The prices in this bid have been arrived at independently, without, for the purpose of restricting competition, any consultation, communication, or agreement with any other bidder or competitor relating to (i) those prices, (ii) the intention to submit a bid, or (iii) the methods or factors used to calculate the prices offered;

(2) The prices in this bid have not been and will not be knowingly disclosed by the bidder, directly or indirectly, to any other bidder or competitor before bid opening (in the case of a sealed bid solicitation) or contract award (in the case of a competitive proposal solicitation) unless otherwise required by law; and

(3) No attempt has been made or will be made by the bidder to induce any other concern to submit or not to submit a bid for the purpose of restricting competition.

(b) Each signature on the bid is considered to be a certification by the signatory that the signatory--

(1) Is the person in the bidder's organization responsible for determining the prices being offered in this bid or proposal, and that the signatory has not participated and will not participate in any action contrary to subparagraphs (a)(1) through (a)(3) above; or

(2) (i) Has been authorized, in writing, to act as agent for the following principals in certifying that those principals have not participated, and will not participate in any action contrary to subparagraphs (a)(1) through (a)(3) above.

[insert full name of person(s) in the bidder's organization responsible for determining the prices offered in this bid or proposal, and the title of his or her position in the bidder's organization];

(ii) As an authorized agent, does certify that the principals named in subdivision (b)(2)(i) above have not participated, and will not participate, in any action contrary to subparagraphs (a)(1) through (a)(3) above; and

(iii) As an agent, has not personally participated, and will not participate in any action contrary to subparagraphs (a)(1) through (a)(3) above.

(c) If the bidder deletes or modifies subparagraph (a)2 above, the bidder must furnish with its bid a signed statement setting forth in detail the circumstances of the disclosure.

[] [Contracting Officer check if following paragraph is applicable]

(d) Non-collusive affidavit. (applicable to contracts for construction and equipment exceeding \$50,000)

(1) Each bidder shall execute, in the form provided by the PHA/IHA, an affidavit to the effect that he/she has not colluded with any other person, firm or corporation in regard to any bid submitted in response to this solicitation. If the successful bidder did not submit the affidavit with his/her bid, he/she must submit it within three (3) working days of bid opening. Failure to submit the affidavit by that date may render the bid nonresponsive. No contract award will be made without a properly executed affidavit.

(2) A fully executed "Non-collusive Affidavit" [] is, [] is not included with the bid.

2. Contingent Fee Representation and Agreement

(a) Definitions. As used in this provision:

"Bona fide employee" means a person, employed by a bidder and subject to the bidder's supervision and control as to time, place, and manner of performance, who neither exerts, nor proposes to exert improper influence to solicit or obtain contracts nor holds out as being able to obtain any contract(s) through improper influence.

"Improper influence" means any influence that induces or tends to induce a PHA/IHA employee or officer to give consideration or to act regarding a PHA/IHA contract on any basis other than the merits of the matter.

(b) The bidder represents and certifies as part of its bid that, except for full-time bona fide employees working solely for the bidder, the bidder:

(1) [] has, [] has not employed or retained any person or company to solicit or obtain this contract; and

(2) [] has, [] has not paid or agreed to pay to any person or company employed or retained to solicit or obtain this contract any commission, percentage, brokerage, or other fee contingent upon or resulting from the award of this contract.

(c) If the answer to either (a)(1) or (a)(2) above is affirmative, the bidder shall make an immediate and full written disclosure to the PHA/IHA Contracting Officer.

(d) Any misrepresentation by the bidder shall give the PHA/IHA the right to (1) terminate the contract; (2) at its discretion, deduct from contract payments the amount of any commission, percentage, brokerage, or other contingent fee; or (3) take other remedy pursuant to the contract.

3. Certification and Disclosure Regarding Payments to Influence Certain Federal Transactions (applicable to contracts exceeding \$100,000)

(a) The definitions and prohibitions contained in Section 1352 of title 31, United States Code, are hereby incorporated by reference in paragraph (b) of this certification.

(b) The bidder, by signing its bid, hereby certifies to the best of his or her knowledge and belief as of December 23, 1989 that:

(1) No Federal appropriated funds have been paid or will be paid to any person for influencing or attempting to influence an officer or employee of any agency, a Member of Congress, an officer or employee of Congress, or an employee of a Member of Congress on his or her behalf in connection with the awarding of a contract resulting from this solicitation;

(2) If any funds other than Federal appropriated funds (including profit or fee received under a covered Federal transaction) have been paid, or will be paid, to any person for influencing or attempting to influence an officer or employee of any agency, a Member of Congress, an officer or employee of Congress, or an employee of a Member of Congress on his or her behalf in connection with this solicitation, the bidder shall complete and submit, with its bid, OMB standard form LLL, "Disclosure of Lobbying Activities;" and

(3) He or she will include the language of this certification in all subcontracts at any tier and require that all recipients of subcontract awards in excess of \$100,000 shall certify and disclose accordingly.

(c) Submission of this certification and disclosure is a prerequisite for making or entering into this contract imposed by section 1352, title 31, United States Code. Any person who makes an expenditure prohibited under this provision or who fails to file or amend the disclosure form to be filed or amended by this provision, shall be subject to a civil penalty of not less than \$10,000, and not more than \$100,000, for each such failure.

(d) Indian tribes (except those chartered by States) and Indian organizations as defined in section 4 of the Indian Self-Determination and Education Assistance Act (25 U.S.C. 450B) are exempt from the requirements of this provision.

4. Organizational Conflicts of Interest Certification

The bidder certifies that to the best of its knowledge and belief and except as otherwise disclosed, he or she does not have any organizational conflict of interest which is defined as a situation in which the nature of work to be performed under this proposed contract and the bidder's organizational, financial, contractual, or other interests may, without some restriction on future activities:

(a) Result in an unfair competitive advantage to the bidder; or,
(b) Impair the bidder's objectivity in performing the contract work. [] In the absence of any actual or apparent conflict, I hereby certify that to the best of my knowledge and belief, no actual or apparent conflict of interest exists with regard to my possible performance of this procurement.

5. Bidder's Certification of Eligibility

(a) By the submission of this bid, the bidder certifies that to the best of its knowledge and belief, neither it, nor any person or firm which has an interest in the bidder's firm, nor any of the bidder's subcontractors, is ineligible to:

(1) Be awarded contracts by any agency of the United States Government, HUD, or the State in which this contract is to be performed; or,

(2) Participate in HUD programs pursuant to 24 CFR Part 24.

(b) The certification in paragraph (a) above is a material representation of fact upon which reliance was placed when making award. If it is later determined that the bidder knowingly rendered an erroneous certification, the contract may be terminated for default, and the bidder may be debarred or suspended from participation in HUD programs and other Federal contract programs.

6. Minimum Bid Acceptance Period

(a) "Acceptance period," as used in this provision, means the number of calendar days available to the PHA/IHA for awarding a contract from the date specified in this solicitation for receipt of bids.

(b) This provision supersedes any language pertaining to the acceptance period that may appear elsewhere in this solicitation.

(c) The PHA/IHA requires a minimum acceptance period of [Contracting Officer insert time period] calendar days.

(d) In the space provided immediately below, bidders may specify a longer acceptance period than the PHA's/IHA's minimum requirement. The bidder allows the following acceptance period: calendar days.

(e) A bid allowing less than the PHA's/IHA's minimum acceptance period will be rejected.

(f) The bidder agrees to execute all that it has undertaken to do, in compliance with its bid, if that bid is accepted in writing within (1) the acceptance period stated in paragraph (c) above or (2) any longer acceptance period stated in paragraph (d) above.

7. Small, Minority, Women-Owned Business Concern Representation

The bidder represents and certifies as part of its bid/ offer that it -- (a)

[] is, [] is not a small business concern. "Small business concern," as used in this provision, means a concern, including its affiliates, that is independently owned and operated, not dominant in the field of operation in which it is bidding, and qualified as a small business under the criteria and size standards in 13 CFR 121.

(b) [] is, [] is not a women-owned business enterprise. "Women-owned business enterprise," as used in this provision, means a business that is at least 51 percent owned by a woman or women who are U.S. citizens and who also control and operate the business.

(c) [] is, [] is not a minority business enterprise. "Minority business enterprise," as used in this provision, means a business which is at least 51 percent owned or controlled by one or more minority group members or, in the case of a publicly owned business, at least 51 percent of its voting stock is owned by one or more minority group members, and whose management and daily operations are controlled by one or more such individuals. For the purpose of this definition, minority group members are:

(Check the block applicable to you)

[] Black Americans	[] Asian Pacific Americans
[] Hispanic Americans	[] Asian Indian Americans
[] Native Americans	[] Hasidic Jewish Americans

8. Indian-Owned Economic Enterprise and Indian Organization Representation (applicable only if this solicitation is for a contract to be performed on a project for an Indian Housing Authority)

The bidder represents and certifies that it:

(a) [] is, [] is not an Indian-owned economic enterprise. "Economic enterprise," as used in this provision, means any commercial, industrial, or business activity established or organized for the purpose of profit, which is at least 51 percent Indian owned. "Indian," as used in this provision, means any person who is a member of any tribe, band, group, pueblo, or community which is recognized by the Federal Government as eligible for services from the Bureau of Indian Affairs and any "Native" as defined in the Alaska Native Claims Settlement Act.

(b) [] is, [] is not an Indian organization. "Indian organization," as used in this provision, means the governing body of any Indian tribe or entity established or recognized by such governing body. ~~Indian "tribe" means any Indian tribe, band, group, pueblo, or~~ form HUD-5369-A (11/92)

community including Native villages and Native groups (including corporations organized by Kenai, Juneau, Sitka, and Kodiak) as defined in the Alaska Native Claims Settlement Act, which is recognized by the Federal Government as eligible for services from the Bureau of Indian Affairs.

9. Certification of Eligibility Under the Davis-Bacon Act (applicable to construction contracts exceeding \$2,000)

(a) By the submission of this bid, the bidder certifies that neither it nor any person or firm who has an interest in the bidder's firm is a person or firm ineligible to be awarded contracts by the United States Government by virtue of section 3(a) of the Davis-Bacon Act or 29 CFR 5.12(a)(1).

(b) No part of the contract resulting from this solicitation shall be subcontracted to any person or firm ineligible to be awarded contracts by the United States Government by virtue of section 3(a) of the Davis-Bacon Act or 29 CFR 5.12(a)(1).

(c) The penalty for making false statements is prescribed in the U. S. Criminal Code, 18 U.S.C. 1001.

10. Certification of Nonsegregated Facilities (applicable to contracts exceeding \$10,000)

(a) The bidder's attention is called to the clause entitled **Equal Employment Opportunity** of the General Conditions of the Contract for Construction.

(b) "Segregated facilities," as used in this provision, means any waiting rooms, work areas, rest rooms and wash rooms, restaurants and other eating areas, time clocks, locker rooms and other storage or dressing areas, parking lots, drinking fountains, recreation or entertainment areas, transportation, and housing facilities provided for employees, that are segregated by explicit directive or are in fact segregated on the basis of race, color, religion, or national origin because of habit, local custom, or otherwise.

(c) By the submission of this bid, the bidder certifies that it does not and will not maintain or provide for its employees any segregated facilities at any of its establishments, and that it does not and will not permit its employees to perform their services at any location under its control where segregated facilities are maintained. The bidder agrees that a breach of this certification is a violation of the Equal Employment Opportunity clause in the contract.

(d) The bidder further agrees that (except where it has obtained identical certifications from proposed subcontractors for specific time periods) prior to entering into subcontracts which exceed \$10,000 and are not exempt from the requirements of the Equal Employment Opportunity clause, it will:

(1) Obtain identical certifications from the proposed subcontractors;

(2) Retain the certifications in its files; and

(3) Forward the following notice to the proposed subcontractors (except if the proposed subcontractors have submitted identical certifications for specific time periods):

Notice to Prospective Subcontractors of Requirement for Certifications of Nonsegregated Facilities

A Certification of Nonsegregated Facilities must be submitted before the award of a subcontract exceeding \$10,000 which is not exempt from the provisions of the Equal Employment Opportunity clause of the prime contract. The certification may be submitted either for each subcontract or for all subcontracts during a period (i.e., quarterly, semiannually, or annually).

Note: The penalty for making false statements in bids is prescribed in 18 U.S.C. 1001.

11. Clean Air and Water Certification (applicable to contracts exceeding \$100,000)

The bidder certifies that:

(a) Any facility to be used in the performance of this contract [] is, [] is not listed on the Environmental Protection Agency List of Violating Facilities:

(b) The bidder will immediately notify the PHA/IHA Contracting Officer, before award, of the receipt of any communication from the Administrator, or a designee, of the Environmental Protection Agency, indicating that any facility that the bidder proposes to use for the performance of the contract is under consideration to be listed on the EPA List of Violating Facilities; and,

(c) The bidder will include a certification substantially the same as this certification, including this paragraph (c), in every nonexempt subcontract.

12. Previous Participation Certificate (applicable to construction and equipment contracts exceeding \$50,000)

(a) The bidder shall complete and submit with his/her bid the Form HUD-2530, "Previous Participation Certificate." If the successful bidder does not submit the certificate with his/her bid, he/she must submit it within three (3) working days of bid opening. Failure to submit the certificate by that date may render the bid nonresponsive. No contract award will be made without a properly executed certificate.

(b) A fully executed "Previous Participation Certificate" [] is, [] is not included with the bid.

13. Bidder's Signature

The bidder hereby certifies that the information contained in these certifications and representations is accurate, complete, and current.

(Signature and Date)

(Typed or Printed Name)

(Title)

(Company Name)

(Company Address)

General Conditions for Construction Contracts - Public Housing Programs

U.S. Department of Housing and Urban
Development
Office of Public and Indian Housing
OMB Approval No. 2577-0157 (exp. 11/30/2023)

Applicability. This form is applicable to any construction/development contract greater than \$250,000.

Public reporting burden for this collection of information is estimated to average 1.0 hours per response, including the time for reviewing instructions, searching existing data sources, gathering and maintaining the data needed, and completing and reviewing the collection of information. Comments regarding the accuracy of this burden estimate and any suggestions for reducing this burden can be sent to the Reports Management Officer, Office of Policy Development and Research, REE, Department of Housing and Urban Development, 451 7th St SW, Room 4176, Washington, DC 20410-5000. When providing comments, please refer to OMB Approval No. 2577-0157. This form includes those clauses required by OMB's common rule on grantee procurement, implemented at HUD in 2 CFR 200, and those requirements set forth in Section 3 of the Housing and Urban Development Act of 1968 and its amendment by the Housing and Community Development Act of 1992, implemented by HUD at 24 CFR Part 75. The form is required for construction contracts awarded by Public Housing Agencies (PHAs). The form is used by Housing Authorities in solicitations to provide necessary contract clauses. If the form were not used, PHAs would be unable to enforce their contracts. Responses to the collection of information are required to obtain a benefit or to retain a benefit. The information requested does not lend itself to confidentiality. HUD may not conduct or sponsor, and a person is not required to respond to a collection of information unless it displays a currently valid OMB number.

IT		Page	Clause	Page
Clause				
1	Definitions	2	Administrative Requirements	
2	Contractor's Responsibility for Work	2	25. Contract Period	9
3	Architect's Duties, Responsibilities and Authority	2	26. Order of Precedence	9
4	Other Contracts	3	27. Payments	9
	Construction Requirements			
		28.	Contract Modifications	10
5	Preconstruction Conference and Notice to Proceed	3	29. Changes	10
6	Construction Progress Schedule	3	30. Suspension of Work	11
7	Site Investigation and Conditions Affecting the Work	3	31. Disputes	11
8	Differing Site Conditions	4	32. Default	11
9	Specifications and Drawings for Construction	4	33. Liquidated	12
10	As-Built Drawings	5	34. Termination of Convenience	12
11	Material and Workmanship	5	35. Assignment of Contract	12
12	Permits and Codes	5	36. Insurance	12
13	Health, Safety, and Accident Prevention	6	37. Subcontracts	13
14	Temporary Buildings and Transportation Materials	6	38. Subcontracting with Small and Minority Firms, Women's Business Enterprise, and Labor Surplus Area Firms	13
15	Availability and Use of Utility Services	6	39. Equal Employment Opportunity	13
16	Protection of Existing Vegetation, Structures, Equipment, Utilities, and Improvements	6	40. Employment, Training, and Contracting Opportunities for Low-Income Persons, Section 3 of the Housing and Urban Development Act of 1968	14
17	Temporary Buildings and Transportation Materials	7	41. Interest of Members of Congress	15
18	Clean Air and Water	7	42. Interest of Members, Officers, or Employees and Former Members, Officers, or Employees	15
19	Energy Efficiency	7	43. Limitations on Payments Made to Influence	15
20	Inspection and Acceptance of Construction	7	44. Royalties and Patents	15
21	Use and Possession Prior to	8	45. Examination and Retention of Contractor's Records	15
22	Warranty of Title	8	46. Labor Standards-Davis-Bacon and Related Acts	15
23	Warranty of	8	47. Non-Federal Prevailing Wage Rates	19
24	Prohibition Against	9	48. Procurement of Recovered	19
	Liens		Materials	

1. Definitions

- (a) "Architect" means the person or other entity engaged by the PHA to perform architectural, engineering, design, and other services related to the work as provided for in the contract. When a PHA uses an engineer to act in this capacity, the terms "architect" and "engineer" shall be synonymous. The Architect shall serve as a technical representative of the Contracting Officer. The Architect's authority is as set forth elsewhere in this contract.
- (b) "Contract" means the contract entered into between the PHA and the Contractor. It includes the forms of Bid, the Bid Bond, the Performance and Payment Bond or Bonds or other assurance of completion, the Certifications, Representations, and Other Statements of Bidders (form HUD-5370), these General Conditions of the Contract for Construction (form HUD-5370), the applicable wage rate determinations from the U.S. Department of Labor, any special conditions included elsewhere in the contract, the specifications, and drawings. It includes all formal changes to any of those documents by addendum, change order, or other modification.
- (c) "Contracting Officer" means the person delegated the authority by the PHA to enter into, administer, and/or terminate this contract and designated as such in writing to the Contractor. The term includes any successor Contracting Officer and any duly authorized representative of the Contracting Officer also designated in writing. The Contracting Officer shall be deemed the authorized agent of the PHA in all dealings with the Contractor.
- (d) "Contractor" means the person or other entity entering into the contract with the PHA to perform all of the work required under the contract.
- (e) "Drawings" means the drawings enumerated in the schedule of drawings contained in the Specifications and as described in the contract clause entitled Specifications and Drawings for Construction herein.
- (f) "HUD" means the United States of America acting through the Department of Housing and Urban Development including the Secretary, or any other person designated to act on its behalf. HUD has agreed, subject to the provisions of an Annual Contributions Terms and Conditions (ACC), to provide financial assistance to the PHA, which includes assistance in financing the work to be performed under this contract. As defined elsewhere in these General Conditions or the contract documents, the determination of HUD may be required to authorize changes in the work or for release of funds to the PHA for payment to the Contractor. Notwithstanding HUD's role, nothing in this contract shall be construed to create any contractual relationship between the Contractor and HUD.
- (g) "Project" means the entire project, whether construction or rehabilitation, the work for which is provided for in whole or in part under this contract.
- (h) "PHA" means the Public Housing Agency organized under applicable state laws which is a party to this contract.
- (i) "Specifications" means the written description of the technical requirements for construction and includes the criteria and tests for determining whether the requirements are met.
- (l) "Work" means materials, workmanship, and manufacture and fabrication of components.
- (a) The Contractor shall furnish all necessary labor, materials, tools, equipment, and transportation necessary for performance of the work. The Contractor shall also furnish all necessary water, heat, light, and power not made available to the Contractor by the PHA pursuant to the clause entitled Availability and Use of Utility Services herein.
- (b) The Contractor shall perform on the site, and with its own organization, work equivalent to at least [] (12 percent unless otherwise indicated) of the total amount of work to be performed under the order. This percentage may be reduced by a supplemental agreement to this order if, during performing the work, the Contractor requests a reduction and the Contracting Officer determines that the reduction would be to the advantage of the PHA.
- (c) At all times during performance of this contract and until the work is completed and accepted, the Contractor shall directly superintend the work or assign and have on the work site a competent superintendent who is satisfactory to the Contracting Officer and has authority to act for the Contractor.
- (d) The Contractor shall be responsible for all damages to persons or property that occur as a result of the Contractor's fault or negligence, and shall take proper safety and health precautions to protect the work, the workers, the public, and the property of others. The Contractor shall hold and save the PHA, its officers and agents, free and harmless from liability of any nature occasioned by the Contractor's performance. The Contractor shall also be responsible for all materials delivered and work performed until completion and acceptance of the entire work, except for any completed unit of work which may have been accepted under the contract.
- (e) The Contractor shall lay out the work from base lines and bench marks indicated on the drawings and be responsible for all lines, levels, and measurements of all work executed under the contract. The Contractor shall verify the figures before laying out the work and will be held responsible for any error resulting from its failure to do so.
- (f) The Contractor shall confine all operations (including storage of materials) on PHA premises to areas authorized or approved by the Contracting Officer.
- (g) The Contractor shall at all times keep the work area, including storage areas, free from accumulations of waste materials. After completing the work and before final inspection, the Contractor shall (1) remove from the premises all scaffolding, equipment, tools, and materials (including rejected materials) that are not the property of the PHA and all rubbish caused by its work; (2) leave the work area in a clean, neat, and orderly condition satisfactory to the Contracting Officer; (3) perform all specified tests; and, (4) deliver the installation in complete and operating condition.
- (h) The Contractor's responsibility will terminate when all work has been completed, the final inspection made, and the work accepted by the Contracting Officer. The Contractor will then be released from further obligation except as required by the warranties specified elsewhere in the contract.

2. Contractor's Responsibility for Work

3. Architect's Duties, Responsibilities, and Authority

- (a) The Architect for this contract, and any successor, shall be designated in writing by the Contracting Officer.

- (b) The Architect shall serve as the Contracting Officer's technical representative with respect to architectural, Schedule engineering, and design matters related to the work performed under the contract. The Architect may provide direction on contract performance. Such direction shall be within the scope of the contract and may not be of a nature which: (1) institutes additional work outside the scope of the contract; (2) constitutes a change as defined in the Changes clause herein; (3) causes an increase or decrease in the cost of the contract; (4) alters the Construction Progress Schedule; or (5) changes any of the other express terms or conditions of the contract.
- (c) The Architect's duties and responsibilities may include but shall not be limited to:
- (1) Making periodic visits to the work site, and on the basis of his/her on-site inspections, issuing written reports to the PHA which shall include all observed deficiencies. The Architect shall file a copy of the report with the Contractor's designated representative at the site;
 - (2) Making modifications in drawings and technical specifications and assisting the Contracting Officer in the preparation of change orders and other contract modifications for issuance by the Contracting Officer;
 - (3) Reviewing and making recommendations with respect to - (i) the Contractor's construction progress schedules; (ii) the Contractor's shop and detailed drawings; (iii) the machinery, mechanical and other equipment and materials or other articles proposed for use by the Contractor; and, (iv) the Contractor's price breakdown and progress payment estimates; and,
 - (4) Assisting in inspections, signing Certificates of Completion, and making recommendations with respect to acceptance of work completed under the contract.

4. Other Contracts

The PHA may undertake or award other contracts for additional work at or near the site of the work under this contract. The Contractor shall fully cooperate with the other contractors and with PHA employees and shall carefully adapt scheduling and performing the work under this contract to accommodate the additional work, heeding any direction that may be provided by the Contracting Officer. The Contractor shall not commit or permit any act that will interfere with the performance of work by any other contractor or by PHA employees

Construction Requirements

5. Pre-construction Conference and Notice to Proceed of the work, and that it has investigated and satisfied itself

- (a) Within ten calendar days of contract execution, and prior to the commencement of work, the Contractor shall attend a preconstruction conference with representatives of the PHA, its Architect, and other interested parties convened by the PHA. The conference will serve to acquaint the participants with the general plan of the construction operation and all other requirements of the contract. The PHA will provide the Contractor with the date, time, and place of the conference.
- (b) The contractor shall begin work upon receipt of a written Notice to Proceed from the Contracting Officer or designee. The Contractor shall not begin work prior to receiving such notice.

6. Construction Progress

- (a) The Contractor shall, within five days after the work commences on the contract or another period of time determined by the Contracting Officer, prepare and submit to the Contracting Officer for approval three copies of a practicable schedule showing the order in which the Contractor proposes to perform the work, and the dates on which the Contractor contemplates starting and completing the several salient features of the work (including acquiring labor, materials, and equipment). The schedule shall be in the form of a progress chart of suitable scale to indicate appropriately the percentage of work scheduled for completion by any given date during the period. If the Contractor fails to submit a schedule within the time prescribed, the Contracting Officer may withhold approval of progress payments or take other remedies under the contract until the Contractor submits the required schedule.
- (b) The Contractor shall enter the actual progress on the chart as required by the Contracting Officer, and immediately deliver three copies of the annotated schedule to the Contracting Officer. If the Contracting Officer determines, upon the basis of inspection conducted pursuant to the clause entitled Inspection and Acceptance of Construction, herein that the Contractor is not meeting the approved schedule, the Contractor shall take steps necessary to improve its progress, including those that may be required by the Contracting Officer, without additional cost to the PHA. In this circumstance, the Contracting Officer may require the Contractor to increase the number of shifts, overtime operations, days of work, and/or the amount of construction plant, and to submit for approval any supplementary schedule or schedules in chart form as the Contracting Officer deems necessary to demonstrate how the approved rate of progress will be regained.
- (c) Failure of the Contractor to comply with the requirements of the Contracting Officer under this clause shall be grounds for a determination by the Contracting Officer that the Contractor is not prosecuting the work with sufficient diligence to ensure completion within the time specified in the Contract. Upon making this determination, the Contracting Officer may terminate the Contractor's right to proceed with the work, or any separable part of it, in accordance with the Default clause of this contract.

7. Site Investigation and Conditions Affecting the Work

- (a) The Contractor acknowledges that it has taken steps reasonably necessary to ascertain the nature and location as to the general and local conditions which can affect the work or its cost, including but not limited to, (1) conditions bearing upon transportation, disposal, handling, and storage of materials; (2) the availability of labor, water, electric power, and roads; (3) uncertainties of weather, river stages, tides, or similar physical conditions at the site; (4) the conformation and conditions of the ground; and (5) the character of equipment and facilities needed preliminary to and during work performance. The Contractor also acknowledges that it has satisfied itself as to the character, quality, and quantity of surface and subsurface materials or obstacles to be encountered insofar as this information is

reasonably ascertainable from an inspection of the site, including all exploratory work done by the PHA, as well as from the drawings and specifications made a part of this contract. Any failure of the Contractor to take the actions described and acknowledged in this paragraph will not relieve the Contractor from responsibility for estimating properly the difficulty and cost of successfully performing the work, or for proceeding to successfully perform the work without additional expense to the PHA.

- (b) The PHA assumes no responsibility for any conclusions or interpretations made by the Contractor based on the information made available by the PHA. Nor does the PHA assume responsibility for any understanding reached or representation made concerning conditions which can affect the work by any of its officers or agents before the execution of this contract, unless that understanding or representation is expressly stated in this contract.

8. Differing Site Conditions

(a) The Contractor shall promptly, and before the conditions are disturbed, give a written notice to the Contracting Officer of (1) subsurface or latent physical conditions at the site which differ materially from those indicated in this contract, or (2) unknown physical conditions at the site(s), of an unusual nature, which differ materially from those ordinarily encountered and generally recognized as inhering in work of the character provided for in the contract.

(b) The Contracting Officer shall investigate the site conditions promptly after receiving the notice. Work shall not proceed at the affected site, except at the

Contractor's risk, until the Contracting Officer has provided written instructions to the Contractor. If the conditions do materially so differ and cause an increase or decrease in the Contractor's cost of, or the time required for, performing any part of the work under this contract, whether or not changed as a result of the conditions, the Contractor shall file a claim in writing to the PHA within ten days after receipt of such instructions and, in any event, before proceeding with the work. An equitable adjustment in the contract price, the delivery schedule, or both shall be made under this clause and the contract modified in writing accordingly.

(c) No request by the Contractor for an equitable adjustment to the contract under this clause shall be allowed, unless the Contractor has given the written notice required; provided, that the time prescribed in (a) above for giving written notice may be extended by the Contracting Officer.

(d) No request by the Contractor for an equitable adjustment to the contract for differing site conditions shall be allowed if made after final payment under this contract.

9. Specifications and Drawings for Construction

(a) The Contractor shall keep on the work site a copy of the drawings and specifications and shall at all times give the Contracting Officer access thereto. Anything mentioned in the specifications and not shown on the drawings, or shown on the drawings and not mentioned in the specifications, shall be of like effect as if shown or mentioned in both. In case of difference between drawings and specifications, the specifications shall govern. In case of discrepancy in the figures, in the drawings, or in the specifications, the matter shall be

promptly submitted to the Contracting Officer, who shall

promptly make a determination in writing. Any adjustment by the Contractor without such a determination shall be at its own risk and expense. The Contracting Officer shall furnish from time to time such detailed drawings and other information as considered necessary, unless otherwise provided.

(b) Wherever in the specifications or upon the drawings the words "directed", "required", "ordered", "designated", "prescribed", or words of like import are used, it shall be understood that the "direction", "requirement", "order", "designation", or "prescription", of the Contracting Officer is intended and similarly the words "approved", "acceptable", "satisfactory", or words of like import shall mean "approved by", or "acceptable to", or "satisfactory to" the Contracting Officer, unless otherwise expressly stated.

(c) Where "as shown" "as indicated", "as detailed", or words of similar import are used, it shall be understood that the reference is made to the drawings accompanying this contract unless stated otherwise. The word "provided" as used herein shall be understood to mean "provide complete in place" that is "furnished and installed".

(d) "Shop drawings" means drawings, submitted to the PHA by the Contractor, subcontractor, or any lower tier subcontractor, showing in detail (1) the proposed fabrication and assembly of structural elements and (2) the installation (i.e., form, fit, and attachment details) of materials of equipment. It includes drawings, diagrams, layouts, schematics, descriptive literature, illustrations, schedules, performance and test data, and similar materials furnished by the Contractor to explain in detail specific portions of the work required by the contract. The PHA may duplicate, use, and disclose in any manner and for any purpose shop drawings delivered under this contract.

(e) If this contract requires shop drawings, the Contractor shall coordinate all such drawings, and review them for accuracy, completeness, and compliance with other contract requirements and shall indicate its approval thereon as evidence of such coordination and review. Shop drawings submitted to the Contracting Officer without evidence of the Contractor's approval may be returned for resubmission. The Contracting Officer will indicate an approval or disapproval of the shop drawings and if not approved as submitted shall indicate the PHA's reasons therefore. Any work done before such approval shall be at the Contractor's risk. Approval by the Contracting Officer shall not relieve the Contractor from responsibility for any errors or omissions in such drawings, nor from responsibility for complying with the requirements of this contract, except with respect to variations described and approved in accordance with (f) below.

(f) If shop drawings show variations from the contract requirements, the Contractor shall describe such variations in writing, separate from the drawings, at the time of submission. If the Architect approves any such variation and the Contracting Officer concurs, the Contracting Officer shall issue an appropriate modification to the contract, except that, if the variation is minor or does not involve a change in price or in time of performance, a modification need not be issued.

(g) It shall be the responsibility of the Contractor to make timely requests of the PHA for such large scale and full size drawings, color schemes, and other additional information, not already in his possession, which shall be

required in the planning and production of the work. Such requests may be submitted as the need arises, but each such request shall be filed in ample time to permit appropriate action to be taken by all parties involved so as to avoid delay.

- (h) The Contractor shall submit to the Contracting Officer for approval four copies (unless otherwise indicated) of all shop drawings as called for under the various headings of these specifications. Three sets (unless otherwise indicated) of all shop drawings, will be retained by the PHA and one set will be returned to the Contractor. As required by the Contracting Officer, the Contractor, upon completing the work under this contract, shall furnish a complete set of all shop drawings as finally approved. These drawings shall show all changes and revisions made up to the time the work is completed and accepted.
- (i) This clause shall be included in all subcontracts at any tier. It shall be the responsibility of the Contractor to ensure that all shop drawings prepared by subcontractors are submitted to the Contracting Officer.

10. As-Built Drawings

- (a) "As-built drawings," as used in this clause, means drawings submitted by the Contractor or subcontractor at any tier to show the construction of a particular structure or work as actually completed under the contract. "As-built drawings" shall be synonymous with "Record drawings."
- (b) As required by the Contracting Officer, the Contractor shall provide the Contracting Officer accurate information to be used in the preparation of permanent as-built drawings. For this purpose, the Contractor shall record on one set of contract drawings all changes from the installations originally indicated, and record final locations of underground lines by depth from finish grade and by accurate horizontal offset distances to permanent surface improvements such as buildings, curbs, or edges of walks.
- (c) This clause shall be included in all subcontracts at any tier. It shall be the responsibility of the Contractor to ensure that all as-built drawings prepared by subcontractors are submitted to the Contracting Officer.

11. Material and Workmanship

- (a) All equipment, material, and articles furnished under this contract shall be new and of the most suitable grade for the purpose intended, unless otherwise specifically provided in this contract. References in the contract to equipment, material, articles, or patented processes by trade name, make, or catalog number, shall be regarded as establishing a standard of quality and shall not be construed as limiting competition. The Contractor may, at its option, use any equipment, material, article, or process that, in the judgment of, and as approved by the Contracting Officer, is equal to that named in the specifications, unless otherwise specifically provided in this contract.
- (b) Approval of equipment and materials.
- (1) The Contractor shall obtain the Contracting Officer's approval of the machinery and mechanical and other equipment to be incorporated into the work. When requesting approval, the Contractor shall furnish to the Contracting Officer the name of the manufacturer, the model number, and other information concerning the performance, capacity, nature, and rating of the

machinery and mechanical and other equipment.

When required by this contract or by the Contracting Officer, the Contractor shall also obtain the

Contracting Officer's approval of the material or articles which the Contractor contemplates incorporating into the work. When requesting approval, the Contractor shall provide full information concerning the material or articles. Machinery, equipment, material, and articles that do not have the required approval shall be installed or used at the risk of subsequent rejection.

- (2) When required by the specifications or the Contracting Officer, the Contractor shall submit appropriately marked samples (and certificates related to them) for approval at the Contractor's expense, with all shipping charges prepaid. The Contractor shall label, or otherwise properly mark on the container, the material or product represented, its place of origin, the name of the producer, the Contractor's name, and the identification of the construction project for which the material or product is intended to be used.
- (3) Certificates shall be submitted in triplicate, describing each sample submitted for approval and certifying that the material, equipment or accessory complies with contract requirements. The certificates shall include the name and brand of the product, name of manufacturer, and the location where produced.
- (4) Approval of a sample shall not constitute a waiver of the PHA right to demand full compliance with contract requirements. Materials, equipment and accessories may be rejected for cause even though samples have been approved.
- (5) Wherever materials are required to comply with recognized standards or specifications, such specifications shall be accepted as establishing the technical qualities and testing methods, but shall not govern the number of tests required to be made nor modify other contract requirements. The Contracting Officer may require laboratory test reports on items submitted for approval or may approve materials on the basis of data submitted in certificates with samples. Check tests will be made on materials delivered for use only as frequently as the Contracting Officer determines necessary to insure compliance of materials with the specifications. The Contractor will assume all costs of retesting materials which fail to meet contract requirements and/or testing materials offered in substitution for those found deficient.
- (6) After approval, samples will be kept in the Project office until completion of work. They may be built into the work after a substantial quantity of the materials they represent has been built in and accepted.
- (c) Requirements concerning lead-based paint. The Contractor shall comply with the requirements concerning lead-based paint contained in the Lead-Based Paint Poisoning Prevention Act (42 U.S.C. 4821-4846) as implemented by 24 CFR Part 35.

12. Permits and Codes

- (a) The Contractor shall give all notices and comply with all applicable laws, ordinances, codes, rules and regulations. Notwithstanding the requirement of the Contractor to comply with the drawings and specifications in the contract, all work installed shall comply with all applicable codes and regulations as amended by any

waivers. Before installing the work, the Contractor shall examine the drawings and the specifications for compliance with applicable codes and regulations bearing on the work and shall immediately report any discrepancy it may discover to the Contracting Officer.

Where the requirements of the drawings and specifications fail to comply with the applicable code or regulation, the Contracting Officer shall modify the contract by change order pursuant to the clause entitled Changes herein to conform to the code or regulation.

- (b) The Contractor shall secure and pay for all permits, fees, and licenses necessary for the proper execution and completion of the work. Where the PHA can arrange for the issuance of all or part of these permits, fees and licenses, without cost to the Contractor, the contract amount shall be reduced accordingly.

13. Health, Safety, and Accident Prevention

(a) In performing this contract, the Contractor shall:

- (1) Ensure that no laborer or mechanic shall be required to work in surroundings or under working conditions which are unsanitary, hazardous, or dangerous to his/her health and/or safety as determined under construction safety and health standards promulgated by the Secretary of Labor by regulation;
- (2) Protect the lives, health, and safety of other persons;
- (3) Prevent damage to property, materials, supplies, and equipment; and,
- (4) Avoid work interruptions.

(b) For these purposes, the Contractor shall:

- (1) Comply with regulations and standards issued by the Secretary of Labor at 29 CFR Part 1926. Failure to comply may result in imposition of sanctions pursuant to the Contract Work Hours and Safety Standards Act (Public Law 91-54, 83 Stat. 96), 40 U.S.C. 3701 et seq.; and
- (2) Include the terms of this clause in every subcontract so that such terms will be binding on each subcontractor.
- (c) The Contractor shall maintain an accurate record of exposure data on all accidents incident to work performed under this contract resulting in death, traumatic injury, occupational disease, or damage to property, materials, supplies, or equipment, and shall report this data in the manner prescribed by 29 CFR Part 1904.
- (d) The Contracting Officer shall notify the Contractor of any noncompliance with these requirements and of the corrective action required. This notice, when delivered to the Contractor or the Contractor's representative at the site of the work, shall be deemed sufficient notice of the noncompliance and corrective action required. After receiving the notice, the Contractor shall immediately take corrective action. If the Contractor fails or refuses to take corrective action promptly, the Contracting Officer may issue an order stopping all or part of the work until satisfactory corrective action has been taken. The Contractor shall not base any claim or request for equitable adjustment for additional time or money on any stop order issued under these circumstances.
- (e) The Contractor shall be responsible for its subcontractors' compliance with the provisions of this clause. The Contractor shall take such action with respect to any subcontract as the PHA, the Secretary of Housing and Urban Development, or the Secretary of Labor shall direct as a means of enforcing such provisions.

14. Temporary Heating

The Contractor shall provide and pay for temporary heating, covering, and enclosures necessary to properly protect all work and materials against damage by dampness and cold, to dry out the work, and to facilitate the completion of the work. Any permanent heating equipment used shall be turned over to the PHA in the condition and at the time required by the specifications.

15. Availability and Use of Utility Services

- (a) The PHA shall make all reasonably required amounts of utilities available to the Contractor from existing outlets and supplies, as specified in the contract. Unless otherwise provided in the contract, the amount of each utility service consumed shall be charged to or paid for by the Contractor at prevailing rates charged to the PHA or, where the utility is produced by the PHA, at reasonable rates determined by the Contracting Officer. The Contractor shall carefully conserve any utilities furnished without charge.
- (b) The Contractor, at its expense and in a manner satisfactory to the Contracting Officer, shall install and maintain all necessary temporary connections and distribution lines, and all meters required to measure the amount of each utility used for the purpose of determining charges. Before final acceptance of the work by the PHA, the Contractor shall remove all the temporary connections, distribution lines, meters, and associated paraphernalia.

16. Protection of Existing Vegetation, Structures, Equipment, Utilities, and Improvements

- (a) The Contractor shall preserve and protect all structures, equipment, and vegetation (such as trees, shrubs, and grass) on or adjacent to the work site, which are not to be removed under this contract, and which do not unreasonably interfere with the work required under this contract.
- (b) The Contractor shall only remove trees when specifically authorized to do so, and shall avoid damaging vegetation that will remain in place. If any limbs or branches of trees are broken during performance of this contract, or by the careless operation of equipment, or by workmen, the Contractor shall trim those limbs or branches with a clean cut and paint the cut with a tree-pruning compound as directed by the Contracting Officer.
- (c) The Contractor shall protect from damage all existing improvements and utilities (1) at or near the work site and (2) on adjacent property of a third party, the locations of which are made known to or should be known by the Contractor. Prior to disturbing the ground at the construction site, the Contractor shall ensure that all underground utility lines are clearly marked.
- (d) The Contractor shall shore up, brace, underpin, secure, and protect as necessary all foundations and other parts of existing structures adjacent to, adjoining, and in the vicinity of the site, which may be affected by the excavations or other operations connected with the construction of the project.
- (e) Any equipment temporarily removed as a result of work under this contract shall be protected, cleaned, and replaced in the same condition as at the time of award of this contract.

- (f) New work which connects to existing work shall correspond in all respects with that to which it connects and/or be similar to existing work unless otherwise required by the specifications.
- (g) No structural members shall be altered or in any way weakened without the written authorization of the Contracting Officer, unless such work is clearly specified in the plans or specifications.
- (h) If the removal of the existing work exposes discolored or unfinished surfaces, or work out of alignment, such surfaces shall be refinished, or the material replaced as necessary to make the continuous work uniform and harmonious. This, however, shall not be construed to require the refinishing or reconstruction of dissimilar finishes previously exposed, or finished surfaces in good condition, but in different planes or on different levels Construction when brought together by the removal of intervening work, unless such refinishing or reconstruction is specified in the plans or specifications.
- (i) The Contractor shall give all required notices to any adjoining or adjacent property owner or other party before the commencement of any work.
- (j) The Contractor shall indemnify and save harmless the PHA from any damages on account of settlement or the loss of lateral support of adjoining property, any damages from changes in topography affecting drainage, and from all loss or expense and all damages for which the PHA may become liable in consequence of such injury or damage to adjoining and adjacent structures and their premises.
- (k) The Contractor shall repair any damage to vegetation, structures, equipment, utilities, or improvements, including those that are the property of a third party, resulting from failure to comply with the requirements of this contract or failure to exercise reasonable care in performing the work. If the Contractor fails or refuses to repair the damage promptly, the Contracting Officer may have the necessary work performed and charge the cost to the Contractor.

17. Temporary Buildings and Transportation of Materials

- (a) Temporary buildings (e.g., storage sheds, shops, offices, sanitary facilities) and utilities may be erected by the Contractor only with the approval of the Contracting Officer and shall be built with labor and materials furnished by the Contractor without expense to the PHA. The temporary buildings and utilities shall remain the property of the Contractor and shall be removed by the Contractor at its expense upon completion of the work. With the written consent of the Contracting Officer, the buildings and utilities may be abandoned and need not be removed.
- (b) The Contractor shall, as directed by the Contracting Officer, use only established roadways, or use temporary roadways constructed by the Contractor when and as authorized by the Contracting Officer. When materials are transported in prosecuting the work, vehicles shall not be loaded beyond the loading capacity recommended by the manufacturer of the vehicle or prescribed by any federal, state, or local law or regulation. When it is necessary to cross curbs or sidewalks, the Contractor shall protect them from damage. The Contractor shall repair or pay for the repair of any damaged curbs, sidewalks, or roads.

18. Clean Air and Water

The contractor shall comply with the Clean Air Act, as amended, 42 USC 7401 et seq., the Federal Water Pollution Control Water Act, as amended, 33 U.S.C. 1251 et seq., and standards issued pursuant thereto in the facilities in which this contract is to be performed.

19. Energy Efficiency

The Contractor shall comply with mandatory standards and policies relating to energy efficiency which are contained in the energy conservation plan issued in compliance with the Energy Policy and Conservation Act (Pub.L. 94-163) for the State in which the work under the contract is performed.

20. Inspection and Acceptance of

- (a) Definitions. As used in this clause -
- (1) "Acceptance" means the act of an authorized representative of the PHA by which the PHA approves and assumes ownership of the work performed under this contract. Acceptance may be partial or complete.
 - (2) "Inspection" means examining and testing the work performed under the contract (including, when appropriate, raw materials, equipment, components, and intermediate assemblies) to determine whether it conforms to contract requirements.
 - (3) "Testing" means that element of inspection that determines the properties or elements, including functional operation of materials, equipment, or their components, by the application of established scientific principles and procedures.
- (b) The Contractor shall maintain an adequate inspection system and perform such inspections as will ensure that the work performed under the contract conforms to contract requirements. All work is subject to PHA inspection and test at all places and at all reasonable times before acceptance to ensure strict compliance with the terms of the contract.
- (c) PHA inspections and tests are for the sole benefit of the PHA and do not: (1) relieve the Contractor of responsibility for providing adequate quality control measures; (2) relieve the Contractor of responsibility for loss or damage of the material before acceptance; (3) constitute or imply acceptance; or, (4) affect the continuing rights of the PHA after acceptance of the completed work under paragraph (j) below.
- (d) The presence or absence of the PHA inspector does not relieve the Contractor from any contract requirement, nor is the inspector authorized to change any term or condition of the specifications without the Contracting Officer's written authorization. All instructions and approvals with respect to the work shall be given to the Contractor by the Contracting Officer.
- (e) The Contractor shall promptly furnish, without additional charge, all facilities, labor, and material reasonably needed for performing such safe and convenient inspections and tests as may be required by the Contracting Officer. The PHA may charge to the Contractor any additional cost of inspection or test when work is not ready at the time specified by the Contractor for inspection or test, or when prior rejection makes reinspection or retest necessary. The PHA shall perform all inspections and tests in a manner that will not unnecessarily delay the work. Special, full size, and performance tests shall be performed as described in the contract.

- (f) The PHA may conduct routine inspections of the construction site on a daily basis.
- (g) The Contractor shall, without charge, replace or correct work found by the PHA not to conform to contract requirements, unless the PHA decides that it is in its interest to accept the work with an appropriate adjustment in contract price. The Contractor shall promptly segregate and remove rejected material from the premises.
- (h) If the Contractor does not promptly replace or correct rejected work, the PHA may (1) by contract or otherwise, replace or correct the work and charge the cost to the Contractor, or (2) terminate for default the Contractor's right to proceed.
- (i) If any work requiring inspection is covered up without approval of the PHA, it must, if requested by the Contracting Officer, be uncovered at the expense of the Contractor. If at any time before final acceptance of the entire work, the Construction PHA considers it necessary or advisable, to examine work already completed by removing or tearing it out, the Contractor, shall on request, promptly furnish all necessary facilities, labor, and material. If such work is found to be defective or nonconforming in any material respect due to the fault of the Contractor or its subcontractors, the Contractor shall defray all the expenses of the examination and of satisfactory reconstruction. If, however, such work is found to meet the requirements of the contract, the Contracting Officer shall make an equitable adjustment to cover the cost of the examination and reconstruction, including, if completion of the work was thereby delayed, an extension of time.
- (j) The Contractor shall notify the Contracting Officer, in as to the date when in its opinion all or a designated portion of the work will be substantially completed and ready for inspection. If the Architect determines that the state of preparedness is as represented, the PHA will promptly arrange for the inspection. Unless otherwise specified in the contract, the PHA shall accept, as soon as practicable after completion and inspection, all work required by the contract or that portion of the work the Contracting Officer determines and designates can be accepted separately. Acceptance shall be final and conclusive except for latent defects, fraud, gross mistakes amounting to fraud, or the PHA's right under any warranty or guarantee.

21. Use and Possession Prior to Completion

- (a) The PHA shall have the right to take possession of or use any completed or partially completed part of the work. Before taking possession of or using any work, the Contracting Officer shall furnish the Contractor a list of items of work remaining to be performed or corrected on those portions of the work that the PHA intends to take possession of or use. However, failure of the Contracting Officer to list any item of work shall not relieve the Contractor of responsibility for complying with the terms of the contract. The PHA's possession or use shall not be deemed an acceptance of any work under the contract.
- (b) While the PHA has such possession or use, the Contractor shall be relieved of the responsibility for (1) the loss of or damage to the work resulting from the PHA's possession or use, notwithstanding the terms of the clause entitled Permits and Codes herein; (2) all maintenance costs on the areas occupied; and, (3) furnishing heat, light, power, and water used in the areas

occupied without proper remuneration therefore. If prior possession or use by the PHA delays the progress of the work or causes additional expense to the Contractor, an equitable adjustment shall be made in the contract price or the time of completion, and the contract shall be modified in writing accordingly.

22. Warranty of Title

The Contractor warrants good title to all materials, supplies, and equipment incorporated in the work and agrees to deliver the premises together with all improvements thereon free from any claims, liens or charges, and agrees further that neither it nor any other person, firm or corporation shall have any right to a lien upon the premises or anything appurtenant thereto.

23. Warranty of

- (a) In addition to any other warranties in this contract, the Contractor warrants, except as provided in paragraph (j) of this clause, that work performed under this contract conforms to the contract requirements and is free of any defect in equipment, material, or workmanship performed by the Contractor or any subcontractor or supplier at any tier. This warranty shall continue for a period of _____ (one year unless otherwise indicated) from the date of final acceptance of the work. If the PHA takes possession of any part of the work before final acceptance, this warranty shall continue for a period of (one year unless otherwise indicated) from the date that the PHA takes possession.
- (b) The Contractor shall remedy, at the Contractor's writing, expense, any failure to conform, or any defect. In addition, the Contractor shall remedy, at the Contractor's expense, any damage to PHA-owned or controlled real or personal property when the damage is the result of—
- (1) The Contractor's failure to conform to contract requirements; or
 - (2) Any defects of equipment, material, workmanship or design furnished by the Contractor.
- (c) The Contractor shall restore any work damaged in fulfilling the terms and conditions of this clause. The Contractor's warranty with respect to work repaired or replaced will run for (one year unless otherwise indicated) from the date of repair or replacement.
- (d) The Contracting Officer shall notify the Contractor, in writing, within a reasonable time after the discovery of any failure, defect or damage.
- (e) If the Contractor fails to remedy any failure, defect, or damage within a reasonable time after receipt of notice, the PHA shall have the right to replace, repair or otherwise remedy the failure, defect, or damage at the Contractor's expense.
- (f) With respect to all warranties, express or implied, from subcontractors, manufacturers, or suppliers for work performed and materials furnished under this contract, the Contractor shall:
- (1) Obtain all warranties that would be given in normal commercial practice;
 - (2) Require all warranties to be executed in writing, for the benefit of the PHA; and,
 - (3) Enforce all warranties for the benefit of the PHA.
- (g) In the event the Contractor's warranty under paragraph (a) of this clause has expired, the PHA may bring suit at its own expense to enforce a subcontractor's, manufacturer's or supplier's warranty.

- (h) Unless a defect is caused by the negligence of the Contractor or subcontractor or supplier at any tier, the Contractor shall not be liable for the repair of any defect of material or design furnished by the PHA nor for the repair of any damage that results from any defect in PHA furnished material or design.
- (i) Notwithstanding any provisions herein to the contrary, the establishment of the time periods in paragraphs (a) and (c) above relate only to the specific obligation of the Contractor to correct the work, and have no relationship to the time within which its obligation to comply with the contract may be sought to be enforced, nor to the time within which proceedings may be commenced to establish the Contractor's liability with respect to its obligation other than specifically to correct the work.
- (j) This warranty shall not limit the PHA's rights under the Inspection and Acceptance of Construction clause of this contract with respect to latent defects, gross mistakes or fraud.

24. Prohibition Against Liens

The Contractor is prohibited from placing a lien on the PHA's property. This prohibition shall apply to all subcontractors at any tier and all materials suppliers.

Administrative Requirements

25. Contract Period

this contract within **60 calendar days** of the effective date of the contract, or within the time schedule established in the notice to proceed issued by the Contracting Officer.

26. Order of Provisions

accordance with the terms and conditions of the In the event of a conflict between these General Conditions and the Specifications, the General Conditions shall prevail. In the event of a conflict between the contract and any applicable state or local law or regulation, the state or local law or regulation shall prevail; provided that such state or local law or regulation does not conflict with, or is less restrictive than applicable federal law, regulation, or Executive Order. In the event of such a conflict, applicable federal law, regulation, and Executive Order shall prevail.

27. Payments

- (a) The PHA shall pay the Contractor the price as provided in this contract.
- (b) The PHA shall make progress payments approximately every 30 days as the work proceeds, on estimates of work accomplished which meets the standards of quality established under the contract, as approved by the Contracting Officer. The PHA may, subject to written determination and approval of the Contracting Officer, make more frequent payments to contractors which are qualified small businesses.
- (c) Before the first progress payment under this contract, the Contractor shall furnish, in such detail as requested by the Contracting Officer, a breakdown of the total contract price showing the amount included therein for each principal category of the work, which shall substantiate the payment amount requested in order to provide a

basis for determining progress payments. The breakdown shall be approved by the Contracting Officer and must be acceptable to HUD. If the contract covers more than one project, the Contractor shall furnish a separate breakdown for each. The values and quantities employed in making up this breakdown are for determining the amount of progress payments and shall not be construed as a basis for additions to or deductions from the contract price. The Contractor shall prorate its overhead and profit over the construction period of the contract.

- (d) The Contractor shall submit, on forms provided by the PHA, periodic estimates showing the value of the work performed during each period based upon the approved submitted not later than _____ days in advance of the date set for payment and are subject to correction and revision as required. The estimates must be approved by the Contracting Officer with the concurrence of the Architect prior to payment. If the contract covers more than one project, the Contractor shall furnish a separate progress payment estimate for each.
- (e) Along with each request for progress payments and the required estimates, the Contractor shall furnish the following certification, or payment shall not be made: I hereby certify, to the best of my knowledge and belief, that:
 - (1) The amounts requested are only for performance in accordance with the specifications, terms, and conditions of the contract;
 - (2) Payments to subcontractors and suppliers have been made from previous payments received under the contract, and timely payments will be made from the proceeds of the payment covered by this certification, in accordance with subcontract agreements; and,
 - (3) This request for progress payments does not include any amounts which the prime contractor intends to withhold or retain from a subcontractor or supplier in subcontract.

Name:

Title:

Date:

- (f) Except as otherwise provided in State law, the PHA shall retain ten (10) percent of the amount of progress payments until completion and acceptance of all work under the contract; except, that if upon completion of 50 percent of the work, the Contracting Officer, after consulting with the Architect, determines that the Contractor's performance and progress are satisfactory, the PHA may make the remaining payments in full for the work subsequently completed. If the Contracting Officer subsequently determines that the Contractor's performance and progress are unsatisfactory, the PHA shall reinstate the ten (10) percent (or other percentage as provided in State law) retainage until such time as the Contracting Officer determines that performance and progress are satisfactory.
- (g) The Contracting Officer may authorize material delivered on the site and preparatory work done to be taken into consideration when computing progress payments.

Material delivered to the Contractor at locations other than the site may also be taken into consideration if the Contractor furnishes satisfactory evidence that (1) it has acquired title to such material; (2) the material is properly stored in a bonded warehouse, storage yard, or similar suitable place as may be approved by the Contracting Officer; (3) the material is insured to cover its full value; and (4) the material will be used to perform this contract. Before any progress payment which includes delivered material is made, the Contractor shall furnish such documentation as the Contracting Officer may require to assure the protection of the PHA's interest in such materials. The Contractor shall remain responsible for such stored material notwithstanding the transfer of title to the PHA.

- (h) All material and work covered by progress payments made shall, at the time of payment become the sole property of the PHA, but this shall not be construed as (1) relieving the Contractor from the sole responsibility for all and work upon which payments have been made or the restoration of any damaged work; or, (2) waiving the right of the PHA to require the fulfillment of all of the terms of the contract. In the event the work of the Contractor has been damaged by other contractors or persons other than employees of the PHA in the course of their employment, the Contractor shall restore such damaged work without cost to the PHA and to seek redress for its damage only from those who directly caused it.
- (i) The PHA shall make the final payment due the Contractor under this contract after (1) completion and final acceptance of all work; and (2) presentation of release of all claims against the PHA arising by virtue of this contract, other than claims, in stated amounts, that the Contractor has specifically excepted from the operation of the release. Each such exception shall embrace no more than one claim, the basis and scope of which shall be clearly defined. The amounts for such excepted claims shall not be included in the request for final payment. A release may also be required of the assignee if the Contractor's claim to amounts payable under this contract has been assigned.
- (j) Prior to making any payment, the Contracting Officer may require the Contractor to furnish receipts or other evidence of payment from all persons performing work and supplying material to the Contractor, if the Contracting Officer determines such evidence is necessary to substantiate claimed costs.
- (k) The PHA shall not; (1) determine or adjust any claims for payment or disputes arising there under between the Contractor and its subcontractors or material suppliers; or, (2) withhold any moneys for the protection of the subcontractors or material suppliers. The failure or refusal of the PHA to withhold moneys from the Contractor shall in nowise impair the obligations of any or sureties under any bonds furnished under this contract.

28. Contract Modifications

- (a) Only the Contracting Officer has authority to modify any term or condition of this contract. Any contract modification shall be authorized in writing.
- (b) The Contracting Officer may modify the contract unilaterally (1) pursuant to a specific authorization stated in a contract clause (e.g., Changes); or (2) for administrative matters which do not change the rights or

responsibilities of the parties (e.g., change in the PHA address). All other contract modifications shall be in the form of supplemental agreements signed by the Contractor and the Contracting Officer.

- (c) When a proposed modification requires the approval of HUD prior to its issuance (e.g., a change order that exceeds the PHA's approved threshold), such modification shall not be effective until the required approval is received by the PHA.

29. Changes

- (a) The Contracting Officer may, at any time, without notice to the sureties, by written order designated or indicated to be a change order, make changes in the work within the general scope of the contract including changes:
 - (1) In the specifications (including drawings and designs);
 - (2) In the method or manner of performance of the work;
 - (3) PHA-furnished facilities, equipment, materials, material services, or site; or,
 - (4) Directing the acceleration in the performance of the work.
- (b) Any other written order or oral order (which, as used in this paragraph (b), includes direction, instruction, interpretation, or determination) from the Contracting Officer that causes a change shall be treated as a change order under this clause; provided, that the Contractor gives the Contracting Officer written notice stating (1) the date, circumstances and source of the order and (2) that the Contractor regards the order as a change order.
- (c) Except as provided in this clause, no order, statement or conduct of the Contracting Officer shall be treated as a change under this clause or entitle the Contractor to an equitable adjustment.
- (d) If any change under this clause causes an increase or decrease in the Contractor's cost of, or the time required for the performance of any part of the work under this contract, whether or not changed by any such order, the Contracting Officer shall make an equitable adjustment and modify the contract in writing. However, except for an adjustment based on defective specifications, no proposal for any change under paragraph (b) above shall be allowed for any costs incurred more than 20 days (5 days for oral orders) before the Contractor gives written notice as required. In the case of defective specifications for which the PHA is responsible, the equitable adjustment shall include any increased cost reasonably incurred by the Contractor in attempting to comply with the defective specifications.
- (e) The Contractor must assert its right to an adjustment under this clause within 30 days after (1) receipt of a written change order under paragraph (a) of this clause, or (2) the furnishing of a written notice under paragraph (b) of this clause, by submitting a written statement surety describing the general nature and the amount of the proposal. If the facts justify it, the Contracting Officer may extend the period for submission. The proposal may be included in the notice required under paragraph (b) above. No proposal by the Contractor for an equitable adjustment shall be allowed if asserted after final payment under this contract.
- (f) The Contractor's written proposal for equitable adjustment shall be submitted in the form of a lump sum proposal supported with an itemized breakdown of all increases and decreases in the contract in at least the following details:

- (1) Direct Costs. Materials (list individual items, the quantity and unit cost of each, and the aggregate cost); Transportation and delivery costs associated with materials; Labor breakdowns by hours or unit costs (identified with specific work to be performed); Construction equipment exclusively necessary for the change; Costs of preparation and/ or revision to shop drawings resulting from the change; Worker's Compensation and Public Liability Insurance; Employment taxes under FICA and FUTA; and, Bond Costs when size of change warrants revision.
- (2) Indirect Costs. Indirect costs may include overhead, general and administrative expenses, and fringe benefits not normally treated as direct costs.
- (3) Profit. The amount of profit shall be negotiated and may vary according to the nature, extent, and complexity of the work required by the change. The allowability of the direct and indirect costs shall be determined in accordance with the Contract Cost Principles and Procedures for Commercial Firms in Part 31 of the Federal Acquisition Regulation (48 CFR 1-31), as implemented by HUD Handbook 2210.18, in effect on the date of this contract. The Contractor shall not be allowed a profit on the profit received by any subcontractor. Equitable adjustments for deleted work shall include a credit for profit and may include a credit for indirect costs. On proposals covering both increases and decreases in the amount of the contract, the application of indirect costs and profit shall be on the net-change in direct costs for the Contractor or subcontractor performing the work.
- (g) The Contractor shall include in the proposal its request for time extension (if any), and shall include sufficient information and dates to demonstrate whether and to extent the change will delay the completion of the contract in its entirety.
- (h) The Contracting Officer shall act on proposals within 30 days after their receipt, or notify the Contractor of the date when such action will be taken.
- (i) Failure to reach an agreement on any proposal shall be a dispute under the clause entitled Disputes herein. Nothing in this clause, however, shall excuse the Contractor from proceeding with the contract as changed.
- (j) Except in an emergency endangering life or property, no change shall be made by the Contractor without a prior order from the Contracting Officer.

30. Suspension of Work

- (a) The Contracting Officer may order the Contractor in writing to suspend, delay, or interrupt all or any part of the work of this contract for the period of time that the Contracting Officer determines appropriate for the convenience of the PHA.
- (b) If the performance of all or any part of the work is, for an unreasonable period of time, suspended, delayed, or interrupted (1) by an act of the Contracting Officer in the administration of this contract, or (2) by the Contracting Officer's failure to act within the time specified (or within a reasonable time if not specified) in this contract an adjustment shall be made for any increase in the cost of performance of the contract (excluding profit) necessarily caused by such unreasonable suspension, delay, or interruption and the contract modified in writing accordingly. However, no adjustment shall be made under this clause for any suspension, delay, or interruption to the extent that performance would have

been so suspended, delayed, or interrupted by any other cause, including the fault or negligence of the Contractor or for which any equitable adjustment is provided for or excluded under any other provision of this contract.

- (c) A claim under this clause shall not be allowed (1) for any costs incurred more than 20 days before the Contractor shall have notified the Contracting Officer in writing of the act or failure to act involved (but this requirement shall not apply as to a claim resulting from a suspension order); and, (2) unless the claim, in an amount stated, is asserted in writing as soon as practicable after the termination of the suspension, delay, or interruption, but not later than the date of final payment under the contract.

31. Disputes

- (a) "Claim," as used in this clause, means a written demand or written assertion by one of the contracting parties seeking, as a matter of right, the payment of money in a sum certain, the adjustment or interpretation of contract terms, or other relief arising under or relating to the contract. A claim arising under the contract, unlike a claim relating to the contract, is a claim that can be resolved under a contract clause that provides for the relief sought by the claimant. A voucher, invoice, or other routine request for payment that is not in dispute when submitted is not a claim. The submission may be converted to a claim by complying with the requirements of this clause, if it is disputed either as to liability or amount or is not acted upon in a reasonable time.
- (b) Except for disputes arising under the clauses entitled Labor Standards - Davis Bacon and Related Acts, herein, all disputes arising under or relating to this contract, what including any claims for damages for the alleged breach thereof which are not disposed of by agreement, shall be resolved under this clause.
- (c) All claims by the Contractor shall be made in writing and submitted to the Contracting Officer for a written decision. A claim by the PHA against the Contractor shall be subject to a written decision by the Contracting Officer.
- (d) The Contracting Officer shall, within 60 (unless otherwise indicated) days after receipt of the request, decide the claim or notify the Contractor of the date by which the decision will be made.
- (e) The Contracting Officer's decision shall be final unless the Contractor (1) appeals in writing to a higher level in the PHA in accordance with the PHA's policy and procedures, (2) refers the appeal to an independent mediator or arbitrator, or (3) files suit in a court of competent jurisdiction. Such appeal must be made within (30 unless otherwise indicated) days after receipt of the Contracting Officer's decision.
- (f) The Contractor shall proceed diligently with performance of this contract, pending final resolution of any request for relief, claim, appeal, or action arising under or relating to the contract, and comply with any decision of the Contracting Officer.

32. Default

- (a) If the Contractor refuses or fails to prosecute the work, or any separable part thereof, with the diligence that will insure its completion within the time specified in this contract, or any extension thereof, or fails to complete said work within this time, the Contracting Officer may, by written notice to the Contractor, terminate the right to

proceed with the work (or separable part of the work) that has been delayed. In this event, the PHA may take over the work and complete it, by contract or otherwise, and may take possession of and use any materials, equipment, and plant on the work site necessary for completing the work. The Contractor and its sureties shall be liable for any damage to the PHA resulting from the Convenience Contractor's refusal or failure to complete the work within the specified time, whether or not the Contractor's right to proceed with the work is terminated. This liability includes any increased costs incurred by the PHA in completing the work.

- (b) The Contractor's right to proceed shall not be terminated or the Contractor charged with damages under this clause if—
- (1) The delay in completing the work arises from unforeseeable causes beyond the control and without the fault or negligence of the Contractor. Examples of such causes include (i) acts of God, or of the public enemy, (ii) acts of the PHA or other governmental entity in either its sovereign or contractual capacity, (iii) acts of another contractor in the performance of a contract with the PHA, (iv) fires, (v) floods, (vi) epidemics, (vii) quarantine restrictions, (viii) strikes, (ix) freight embargoes, (x) unusually severe weather, or (xi) delays of subcontractors or suppliers at any tier arising from unforeseeable causes beyond the control and without the fault or negligence of both the Contractor and the subcontractors or suppliers; and
- (2) The Contractor, within days (10 days unless otherwise indicated) from the beginning of such delay (unless extended by the Contracting Officer) notifies the Contracting Officer in writing of the causes of delay. The Contracting Officer shall ascertain the facts and the extent of the delay. If, in the judgment of the Contracting Officer, the findings of fact warrant such action, time for completing the work shall be extended by written modification to the contract. The findings of the Contracting Officer shall be reduced to a written decision which shall be subject to the provisions of the Disputes clause of this contract.
- (c) If, after termination of the Contractor's right to proceed, it is determined that the Contractor was not in default, or that the delay was excusable, the rights and obligations of the parties will be the same as if the termination had been for convenience of the PHA.

33. Liquidated Damages

- (a) If the Contractor fails to complete the work within the time specified in the contract, or any extension, as specified in the clause entitled Default of this contract, the Contractor shall pay to the PHA as liquidated damages, the sum of **\$200 per day per dwelling for each day of delay**. If different completion dates are Contracting Officer. specified in the contract for separate parts or stages of the work, the amount of liquidated damages shall be assessed on those parts or stages which are delayed. To the extent that the Contractor's delay or nonperformance is excused under another clause in this contract, liquidated damages shall not be due the PHA. The Contractor remains liable for damages caused other than by delay.
- (b) If the PHA terminates the Contractor's right to proceed, the resulting damage will consist of liquidated damages until such reasonable time as may be required for final

completion of the work together with any increased costs occasioned the PHA in completing the work.

- (c) If the PHA does not terminate the Contractor's right to proceed, the resulting damage will consist of liquidated damages until the work is completed or accepted.

34. Termination for

- (a) The Contracting Officer may terminate this contract in whole, or in part, whenever the Contracting Officer determines that such termination is in the best interest of the PHA. Any such termination shall be effected by delivery to the Contractor of a Notice of Termination specifying the extent to which the performance of the work under the contract is terminated, and the date upon which such termination becomes effective.
- (b) If the performance of the work is terminated, either in whole or in part, the PHA shall be liable to the Contractor for reasonable and proper costs resulting from such termination upon the receipt by the PHA of a properly presented claim setting out in detail: (1) the total cost of the work performed to date of termination less the total amount of contract payments made to the Contractor; (2) the cost (including reasonable profit) of settling and paying claims under subcontracts and material orders for work performed and materials and supplies delivered to the site, payment for which has not been made by the PHA to the Contractor or by the Contractor to the subcontractor or supplier; (3) the cost of preserving and protecting the work already performed until the PHA or assignee takes possession thereof or assumes responsibility therefore; (4) the actual or estimated cost of legal and accounting services reasonably necessary to prepare and present the termination claim to the PHA; and (5) an amount constituting a reasonable profit on the value of the work performed by the Contractor.
- (c) The Contracting Officer will act on the Contractor's claim within days (60 days unless otherwise indicated) of receipt of the Contractor's claim.
- (d) Any disputes with regard to this clause are expressly made subject to the provisions of the Disputes clause of this contract.

35. Assignment of Contract

The Contractor shall not assign or transfer any interest in this contract; except that claims for monies due or to become due from the PHA under the contract may be assigned to a bank, trust company, or other financial institution. Such assignments of claims shall only be made with the written concurrence of the Contracting Officer. If the Contractor is a partnership, this contract shall inure to the benefit of the surviving or remaining member(s) of such partnership as approved by the

36. Insurance

- (a) Before commencing work, the Contractor and each subcontractor shall furnish the PHA with certificates of insurance showing the following insurance is in force and will insure all operations under the Contract:
- (1) Workers' Compensation, in accordance with state or Territorial Workers' Compensation laws.
- (2) Commercial General Liability with a combined single limit for bodily injury and property damage of not less than \$ 1 million occurrence, \$2 million aggregate

per occurrence to protect the Contractor and each subcontractor against claims for bodily injury or death and damage to the property of others. This shall cover the use of all equipment, hoists, and vehicles on the site(s) not covered by Automobile Liability under (3) below. If the Contractor has a "claims made" policy, then the following additional requirements apply: the policy must provide a "retroactive date" which must be on or before the execution date of the Contract; and the extended reporting period may not be less than five years following the completion date of the Contract.

- (3) Automobile Liability on owned and non-owned motor vehicles used on the site(s) or in connection therewith for a combined single limit for bodily injury and property damage of not less than \$ 50 K per occurrence.
- (b) Before commencing work, the Contractor shall furnish the PHA with a certificate of insurance evidencing that Builder's Risk (fire and extended coverage) Insurance on all work in place and/or materials stored at the building site(s), including foundations and building equipment, is in force. The Builder's Risk Insurance shall be for the benefit of the Contractor and the PHA as their interests may appear and each shall be named in the policy or policies as an insured. The Contractor in installing equipment supplied by the PHA shall carry insurance on such equipment from the time the Contractor takes possession thereof until the Contract work is accepted by the PHA. The Builder's Risk Insurance need not be carried on excavations, piers, footings, or foundations until such time as work on the superstructure is started. It

need not be carried on landscape work. Policies shall furnish coverage at all times for the full cash value of all completed construction, as well as materials in place and/or stored at the site(s), whether or not partial payment has been made by the PHA. The Contractor may terminate this insurance on buildings as of the date taken over for occupancy by the PHA. The Contractor is not required to carry Builder's Risk Insurance for modernization work which does not involve structural alterations or additions and where the PHA's existing fire and extended coverage policy can be endorsed to include such work.

- (c) All insurance shall be carried with companies which are financially responsible and admitted to do business in the State in which the project is located. If any such insurance is due to expire during the construction period, the Contractor (including subcontractors, as applicable) shall not permit the coverage to lapse and shall furnish evidence of coverage to the Contracting Officer. All certificates of insurance, as evidence of coverage, shall provide that no coverage may be canceled or non-renewed by the insurance company until at least 30 days prior written notice has been given to the Contracting Officer.

37. Subcontracts

- (a) Definitions. As used in this contract -

(1) "Subcontract" means any contract, purchase order, or other purchase agreement, including modifications and change orders to the foregoing, entered into by a subcontractor to furnish supplies, materials, equipment, and services for the performance of the prime contract or a subcontract.

(2) "Subcontractor" means any supplier, vendor, or firm that furnishes supplies, materials, equipment, or services to or for the Contractor or another subcontractor.

- (b) The Contractor shall not enter into any subcontract with any subcontractor who has been temporarily denied participation in a HUD program or who has been suspended or debarred from participating in contracting programs by any agency of the United States Government or of the state in which the work under this contract is to be performed.
- (c) The Contractor shall be as fully responsible for the acts or omissions of its subcontractors, and of persons either directly or indirectly employed by them as for the acts or omissions of persons directly employed by the
- (d) The Contractor shall insert appropriate clauses in all subcontracts to bind subcontractors to the terms and conditions of this contract insofar as they are applicable to the work of subcontractors.
- (e) Nothing contained in this contract shall create any contractual relationship between any subcontractor and the PHA or between the subcontractor and HUD.

38. Subcontracting with Small and Minority Firms, Women's Business Enterprise, and Labor Surplus Area Firms

The Contractor shall take the following steps to ensure that, whenever possible, subcontracts are awarded to small business firms, minority firms, women's business enterprises, and labor surplus area firms:

- (a) Placing qualified small and minority businesses and women's business enterprises on solicitation lists;
- (b) Ensuring that small and minority businesses and women's business enterprises are solicited whenever they are potential sources;
- (c) Dividing total requirements, when economically feasible, into smaller tasks or quantities to permit maximum participation by small and minority businesses and women's business enterprises;
- (d) Establishing delivery schedules, where the requirements of the contract permit, which encourage participation by small and minority businesses and women's business enterprises; and
- (e) Using the services and assistance of the U.S. Small Business Administration, the Minority Business Development Agency of the U.S. Department of Commerce, and State and local governmental small business agencies.

39. Equal Employment Opportunity

During the performance of this contract, the Contractor/Seller agrees as follows:

- (a) The Contractor/Seller shall not discriminate against any employee or applicant for employment because of race color, religion, sex, sexual orientation, gender identity, disability, or national origin.
- (b) The Contractor/Seller shall take affirmative action to ensure that applicants are employed, and that employees are treated during employment without regard to their race, color, religion, sex, sexual orientation, gender identity, disability, or national origin. Such action shall include, but not be limited to, (1) employment, (2) upgrading demotion, (4) transfer, (5) recruitment or recruitment advertising, (6) layoff or termination, (7) rates of pay or other forms of compensation, and (8) selection for training, including apprenticeship

(c) The Contractor/Seller agrees to post in conspicuous places available to employees and applicants for employment the notices to be provided by the Contracting Officer setting forth the provisions of this nondiscrimination clause.

(d) The Contractor/Seller shall, in all solicitations or advertisements for employees placed by or on behalf of the Contractor/Seller, state that all qualified applicants will receive consideration for employment without regard to race, color, religion, sex, or national origin.

(e) The Contractor/Seller shall send, to each labor union or representative of workers with which it has a collective bargaining agreement or other contract or understanding, the notice to be provided by the Contracting Officer advising the labor union or workers' representative of the Contractor's commitments under this clause, and post copies of the notice in conspicuous places available to employees and applicants for employment.

(f) The Contractor/Seller shall comply with Executive Order 11246, as amended, and the rules, regulations, and orders of the Secretary of Labor.

(g) The Contractor/Seller shall furnish all information and reports required by Executive Order 11246, as amended, Section 503 of the Rehabilitation Act of 1973, as amended, and by rules, regulations, and orders of the Secretary of Labor, or pursuant thereto. The Contractor/Seller shall permit access to its books, records, and accounts by the Secretary of Labor for purposes of investigation to ascertain compliance with such rules, regulations, and orders.

(h) In the event of a that the Contractor/Seller is in noncompliance with the nondiscrimination clauses of this contract or with any of such rules, regulations, or orders, this contract may be canceled, terminated or suspended in whole or in part and the contractor/seller may be declared ineligible for further Government contracts in accordance with procedures authorized in Executive Order 11246 of September 24, 1965, and such other sanctions may be imposed and remedies invoked as provided in Executive Order 11246 of September 24, 1965, or by rule, regulation, or order of the Secretary of Labor, or as otherwise provided by law.

(i) The contractor/seller will include the provisions of paragraphs (a) through (h) in every subcontract or purchase order unless exempted by rules, regulations, or orders of the Secretary of Labor issued pursuant to section 204 of Executive Order 11246 of September 24, 1965, so that such provisions will be binding upon each sub[contractor/seller] or vendor. The [contractor/seller] will take such action with respect to any subcontract or purchase order as may be directed by the Secretary of Labor as a means of enforcing such provisions in cluding sanctions for noncompliance: Provided, however, that in the event the [contractor/seller] becomes involved in, or is threatened with, litigation with a subcontractor or vendor as a result of such direction, the [contractor/seller] may request the United States to enter into such litigation to protect the interests of the United States.

(j) Compliance with the requirements of this clause shall be to the maximum extent consistent with, but not in derogation of, compliance with section 7(b) of the Indian Self-Determination and Education Assistance Act and the Indian Preference clause of this contract.

40. Employment, Training, and Contracting Opportunities for Low-Income Persons, Section 3 of the Housing and Urban Development Act of 1968.

(a) The work to be performed under this contract is subject to the

requirements of Section 3 of the Housing and Urban Development Act of 1968, as amended, 12 U.S.C. 1701u (section

3). The purpose of section 3 is to ensure that employment and other economic opportunities generated by HUD assistance or HUD-assisted projects covered by Section 3, shall, to the greatest extent feasible, be directed to low- and very low-income persons, particularly persons who are recipients of HUD assistance for housing.

(b) The parties to this contract agree to comply with HUD's regulations in 24 CFR Part 75, which implement Section 3. As evidenced by their execution of this contract, the parties to this contract certify that they are under no contractual or other impediment that would prevent them from complying with the Part 75 regulations.

(c) The contractor agrees to send to each labor organization or representative of workers with which the contractor has a collective bargaining agreement or other understanding, if any, a notice advising the labor organization or workers' representative of the contractor's commitments under this section 3 clause and will post copies of the notice in conspicuous places at the work site where both employees and applicants for training and employment positions can see the notice. The notice shall describe the Section 3 prioritization requirements and shall state the minimum percentages of labor hour requirements established in the Benchmark Notice (FR-6085-N-04).

(d) The contractor agrees to include this section 3 clause in every subcontract subject to compliance with regulations in 24 CFR Part 75, and agrees to take appropriate action, as provided in an applicable provision of the subcontract or in this section 3 clause, upon a finding that the subcontractor is in violation of the regulations in 24 CFR Part 75. The contractor will not subcontract with any subcontractor where the contractor has notice or knowledge that the subcontractor has been found in violation of the regulations in 24 CFR Part 75.

(e) Noncompliance with HUD's regulations in 24 CFR Part 75 may result in sanctions, termination of this contract for default, and debarment or suspension from future HUD assisted contracts.

(f) Contracts, subcontracts, grants, or subgrants subject to Section 7(b) of the Indian Self-Determination and Education Assistance Act (25 U.S.C. 5307(b)) or subject to tribal preference requirements as authorized under 101(k) of the Native American Housing Assistance and Self-Determination Act (25 U.S.C. 4111(k)) must provide preferences in employment, training, and business opportunities to Indians and Indian organizations, and are therefore not subject to the requirements of 24 CFR Part 75.

41. Interest of Members of Congress

No member of or delegate to the Congress of the United States of America shall be admitted to any share or part of this contract or to any benefit that may arise therefrom.

42. Interest of Members, Officers, or Employees and Former Members, Officers, or Employees

No member, officer, or employee of the PHA, no member of the governing body of the locality in which the project is situated, no member of the governing body of the locality in which the PHA was activated, and no other public official of such locality or localities who exercises any functions or responsibilities with respect to the project, shall, during his or her tenure, or for one year thereafter, have any interest, direct or indirect, in this contract or the proceeds thereof.

43. Limitations on Payments made to Influence Certain Federal Financial Transactions

- (a) The Contractor agrees to comply with Section 1352 of Title 31, United States Code which prohibits the use of Acts Federal appropriated funds to pay any person for influencing or attempting to influence an officer or employee of any agency, a Member of Congress, and officer or employee of Congress, or an employee of a Member of Congress in connection with any of the following covered Federal actions: the awarding of any Federal contract; the making of any Federal grant; the making of any Federal loan; the entering into of any cooperative agreement; or the modification of any Federal contract, grant, loan, or cooperative agreement.
- (b) The Contractor further agrees to comply with the requirement of the Act to furnish a disclosure (OMB Standard Form LLL, Disclosure of Lobbying Activities) if any funds other than Federal appropriated funds (including profit or fee received under a covered Federal transaction) have been paid, or will be paid, to any person for influencing or attempting to influence an officer or employee of any agency, a Member of Congress, an officer or employee of Congress, or an employee of a Member of Congress in connection with a Federal contract, grant, loan, or cooperative agreement.

44. Royalties and Patents

The Contractor shall pay all royalties and license fees. It shall defend all suits or claims for infringement of any patent rights and shall save the PHA harmless from loss on account thereof; except that the PHA shall be responsible for all such loss when a particular design, process or the product of a particular manufacturer or manufacturers is specified and the Contractor has no reason to believe that the specified design, process, or product is an infringement. If, however, the Contractor has reason to believe that any design, process or product specified is an infringement of a patent, the Contractor shall promptly notify the Contracting Officer. Failure to give such notice shall make the Contractor responsible for resultant loss.

45. Examination and Retention of Contractor's Records

- (a) The PHA, HUD, or Comptroller General of the United States, or any of their duly authorized representatives shall, until 3 years after final payment under this contract, have access to and the right to examine any of the Contractor's directly pertinent books, documents, papers, or other records involving transactions related to this contract for the purpose of making audit, examination, excerpts, and transcriptions.
- (b) The Contractor agrees to include in first-tier subcontracts under this contract a clause substantially the same as paragraph (a) above. "Subcontract," as used in this clause, excludes purchase orders not exceeding \$10,000.
- (c) The periods of access and examination in paragraphs (a) and (b) above for records relating to (1) appeals under the Disputes clause of this contract, (2) litigation or settlement of claims arising from the performance of this contract, or (3) costs and expenses of this contract to which the PHA, HUD, or Comptroller General or any of their duly authorized representatives has taken exception shall continue until disposition of such appeals, litigation, claims, or exceptions.

46. Labor Standards - Davis-Bacon and Related

If the total amount of this contract exceeds \$2,000, the Federal labor standards set forth in the clause below shall apply to the development or construction work to be performed under the contract.

- (a) Minimum Wages.
 - (1) All laborers and mechanics employed under this contract in the development or construction of the project(s) involved will be paid unconditionally and not less often than once a week, and without subsequent deduction or rebate on any account (except such payroll deductions as are permitted by regulations issued by the Secretary of Labor under the Copeland Act (29 CFR Part 3)), the full amount of wages and bona fide fringe benefits (or cash equivalents thereof) due at time of payment computed at rates not less than those contained in the wage determination of the Secretary of Labor which is attached hereto and made a part hereof, regardless of any contractual relationship which may be alleged to exist between the Contractor and such laborers and mechanics. Contributions made or costs reasonably anticipated for bona fide fringe benefits under Section 1(b)(2) of the Davis-Bacon Act on behalf of laborers or mechanics are considered wages paid to such laborers or mechanics, subject to the provisions of 29 CFR 5.5(a)(1)(iv); also, regular contributions made or costs incurred for more than a weekly period (but not less often than quarterly) under plans, funds, or programs which cover the regular weekly period, are deemed to be constructively made or incurred during such weekly period. Such laborers and mechanics shall be paid the appropriate wage rate and fringe benefits in the wage determination for the classification of work actually performed, without regard to skill, except as provided in 29 CFR 5.5(a)(4). Laborers or mechanics performing work in more than one classification may be compensated at the rate specified for each classification for the time actually worked therein; provided, that the employer's payroll records accurately set forth the time spent in each classification in which work is performed. The wage determination (including any additional classification and wage rates conformed under 29 CFR 5.5(a)(1)(ii) and the Davis-Bacon poster (WH-1321) shall

be posted at all times by the Contractor and its subcontractors at the site of the work in a prominent and accessible place where it can be easily seen by the workers.

(2) (i) Any class of laborers or mechanics, including helpers, which is not listed in the wage determination and which is to be employed under the contract shall be classified in conformance with the wage determination. HUD shall approve an additional classification and wage rate and fringe benefits therefor only when all the following criteria have been met: (A) The work to be performed by the classification requested is not performed by a classification in the wage determination; and (B) The classification is utilized in the area by the construction industry; and (C) The proposed wage rate, including any bona fide fringe benefits, bears a reasonable relationship to the wage rates contained in the wage determination.

(ii) If the Contractor and the laborers and mechanics to be employed in the classification (if known), or their representatives, and HUD or its designee agree on the classification and wage rate (including the amount designated for fringe benefits where appropriate), a report of the action taken shall be sent by HUD or its designee to the Administrator of the Wage and Hour Division, Employee Standards Administration, U.S. Department of Labor, Washington, DC 20210. The Administrator, or an authorized representative, will approve, modify, or disapprove every additional classification action within 30 days of receipt and so advise HUD or its designee or will notify HUD or its designee within the 30-day period that additional time is necessary.

(iii) In the event the Contractor, the laborers or mechanics to be employed in the classification or their representatives, and HUD or its designee do not agree on the proposed classification and wage rate (including the amount designated for fringe benefits, where appropriate), HUD or its designee shall refer the questions, including the views of all interested parties and the recommendation of HUD or its designee, to the Administrator of the Wage and Hour Division for determination. The Administrator, or an authorized representative, will issue a determination within 30 days of receipt and so advise HUD or its designee or will notify HUD or its designee within the 30-day period that additional time is necessary.

(iv) The wage rate (including fringe benefits where appropriate) determined pursuant to subparagraphs (a)(2)(ii) or (iii) of this clause shall be paid to all workers performing work in the classification under this contract from the first day on which work is performed in classification.

(3) Whenever the minimum wage rate prescribed in the contract for a class of laborers or mechanics includes a fringe benefit which is not expressed as an hourly rate, the Contractor shall either pay the benefit as stated in the wage determination or shall pay another bona fide fringe benefit or an hourly cash equivalent thereof.

(4) If the Contractor does not make payments to a trustee or other third person, the Contractor may consider as part of the wages of any laborer or mechanic the

amount of any costs reasonably anticipated in providing bona fide fringe benefits under a plan or program; provided, that the Secretary of Labor has found, upon the written request of the Contractor, that the applicable standards of the Davis-Bacon Act have been met. The Secretary of Labor may require the Contractor to set aside in a separate account assets for the meeting of obligations under the plan or program.

(b) Withholding of funds. HUD or its designee shall, upon its own action or upon written request of an authorized representative of the Department of Labor, withhold or cause to be withheld from the Contractor under this contract or any other Federal contract with the same prime Contractor, or any other Federally-assisted contract subject to Davis-Bacon prevailing wage requirements, which is held by the same prime Contractor, so much of the accrued payments or advances as may be considered necessary to pay laborers and mechanics, including apprentices, trainees, and helpers, employed by the Contractor or any subcontractor the full amount of wages required by the contract. In the event of failure to pay any laborer or mechanic, including any apprentice, trainee, or helper, employed or working in the construction or development of the project, all or part of the wages required by the contract, HUD or its designee may, after written notice to the Contractor, take such action as may be necessary to cause the suspension of any further payment, advance, or guarantee of funds until such violations have ceased. HUD or its designee may, after written notice to the Contractor, disburse such amounts withheld for and on account of the Contractor or subcontractor to the respective employees to whom they are due.

(c) Payrolls and basic records.

(1) Payrolls and basic records relating thereto shall be maintained by the Contractor during the course of the work and preserved for a period of three years thereafter for all laborers and mechanics working in the construction or development of the project. Such records shall contain the name, address, and social security number of each such worker, his or her correct classification, hourly rates of wages paid (including rates of contributions or costs anticipated for bona fide fringe benefits or cash equivalents thereof of the types described in section 1(b)(2)(B) of the Davis-Bacon Act), daily and weekly number of hours worked, deductions made, and actual wages paid. Whenever the Secretary of Labor has found, under 29 CFR 5.5(a)(1)(iv), that the wages of any laborer or mechanic include the amount of costs reasonably anticipated in providing benefits under a plan or program described in section 1(b)(2)(B) of the Davis-Bacon Act, the Contractor shall maintain records which show that the commitment to provide such benefits is enforceable, that the plan or program is financially responsible, and that the plan or program has been communicated in writing to the laborers or mechanics affected, and records which show the costs anticipated or the actual cost incurred in providing such benefits. Contractors employing apprentices or trainees under approved programs shall maintain written evidence of the registration of apprenticeship programs and certification of trainee programs, the registration of the apprentices and trainees, and the ratios and wage rates prescribed in the applicable programs.

(2) (i) The Contractor shall submit weekly for each week in which any contract work is performed a copy of all payrolls to the Contracting Officer for transmission to HUD or its designee. The payrolls submitted shall set out accurately and completely all of the information required to be maintained under subparagraph (c)(1) of this clause. This information may be submitted in any form desired. Optional Form WH-347 (Federal Stock Number 029-005-00014-1) is available for this purpose and may be purchased from the Superintendent of Documents, U.S. Government Printing Office, Washington, D.C. 20402. The Contractor is responsible for the submission of copies of payrolls by all subcontractors. (Approved by the Office of Management and Budget under OMB Control Number 1214-0149.)

(ii) Each payroll submitted shall be accompanied by a "Statement of Compliance," signed by the Contractor or subcontractor or his or her agent who pays or supervises the payment of the persons employed under the contract and shall certify the following:

- (A) That the payroll for the payroll period contains the information required to be maintained under paragraph (c) (1) of this clause and that such information is correct and complete;
 - (B) That each laborer or mechanic (including each helper, apprentice, and trainee) employed on the contract during the payroll period has been paid the full weekly wages earned, without rebate, either directly or indirectly, and that no deductions have been made either directly or indirectly from the full wages earned, other than permissible deductions as set forth in 29 CFR Part 3; and
 - (C) That each laborer or mechanic has been paid not less than the applicable wage rates and fringe benefits or cash equivalents for the classification of work performed, as specified in the applicable wage determination incorporated into the contract.
- (iii) The weekly submission of a properly executed certification set forth on the reverse side of Optional Form WH-347 shall satisfy the requirements for submission of the "Statement of Compliance" required by subparagraph (c)(2)(ii) of this clause.
- (iv) The falsification of any of the above certifications may subject the Contractor or subcontractor to civil or criminal prosecution under Section 1001 of Title 18 and Section 3729 of Title 31 of the United States Code.

(3) The Contractor or subcontractor shall make the records required under subparagraph (c)(1) available for inspection, copying, or transcription by authorized representatives of HUD or its designee, the Contracting Officer, or the Department of Labor and shall permit such representatives to interview employees during working hours on the job. If the Contractor or subcontractor fails to submit the required records or to make them available, HUD or its designee may, after written notice to the Contractor, take such action as may be necessary to suspension of any further payment, advance, or guarantee of funds. Furthermore, failure to submit the required records upon request or to

make such records available may be grounds for debarment action pursuant to 29 CFR 5.12.

- (d) (1) Apprentices. Apprentices will be permitted to work at less than the predetermined rate for the work they performed when they are employed pursuant to and individually registered in a bona fide apprenticeship program registered with the U.S. Department of Labor, Employment and Training Administration, Office of Apprenticeship and Training, Employer and Labor Services (OATELS), or with a State Apprenticeship Agency recognized by OATELS, or if a person is employed in his or her first 90 days of probationary employment as an apprentice in such an apprenticeship program, who is not individually registered in the program, but who has been certified by OATELS or a State Apprenticeship Agency (where appropriate) to be eligible for probationary employment as an apprentice. The allowable ratio of apprentices to journeymen on the job site in any craft classification shall not be greater than the ratio permitted to the Contractor as to the entire work force under the registered program. Any worker listed on a payroll at an apprentice wage rate, who is not registered or otherwise employed as stated in this paragraph, shall be paid not less than the applicable wage rate on the wage determination for the classification of work actually performed. In addition, any apprentice performing work on the job site in excess of the ratio permitted under the registered program shall be paid not less than the applicable wage rate on the wage determination for the work actually performed. Where a contractor is performing construction on a project in a locality other than that in which its program is registered, the ratios and wage rates (expressed in percentages of the journeyman's hourly rate) specified in the Contractor's or subcontractor's registered program shall be observed. Every apprentice must be paid at not less than the rate specified in the registered program for the apprentice's level of progress, expressed as a percentage of the journeyman hourly rate specified in the applicable wage determination. Apprentices shall be paid fringe benefits in accordance with the provisions of the apprenticeship program. If the apprenticeship program does not specify fringe benefits, apprentices must be paid the full amount of fringe benefits listed on the wage determination for the applicable classification. If the Administrator of the Wage and Hour Division determines that a different practice prevails for the applicable apprentice classification, fringes shall be paid in accordance with that determination. In the event OATELS, or a State Apprenticeship Agency recognized by OATELS, withdraws approval of an apprenticeship program, the Contractor will no longer be permitted to utilize apprentices at less than the applicable predetermined rate for the work performed until an acceptable program is approved.

(2) Trainees. Except as provided in 29 CFR 5.16, trainees will not be permitted to work at less than the predetermined rate for the work performed unless they are employed pursuant to and individually registered in a program which has received prior approval, evidenced by formal certification by the U.S. cause the Department of Labor, Employment and Training Administration. The ratio of trainees to journeymen on the job site shall not be greater than permitted under

the plan approved by the Employment and Training Administration. Every trainee must be paid at not less than the rate specified in the approved program for the trainee's level of progress, expressed as a percentage of the journeyman hourly rate specified in the applicable wage determination. Trainees shall be paid fringe benefits in accordance with the provisions of the trainee program. If the trainee program does not mention fringe benefits, trainees shall be paid the full amount of fringe benefits listed in the wage determination unless the Administrator of the Wage and Hour Division determines that there is an apprenticeship program associated with the corresponding journeyman wage rate in the wage determination which provides for less than full fringe benefits for apprentices. Any employee listed on the payroll at a trainee rate who is not registered and participating in a training plan approved by the Employment and Training Administration shall be paid not less than the applicable wage rate in the wage determination for the classification of work actually performed. In addition, any trainee performing work on the job site in excess of the ratio permitted under the registered program shall be paid not less than the applicable wage rate in the wage determination for the work actually performed. In the event the Employment and Training Administration withdraws approval of a training program, the Contractor will no longer be permitted to utilize trainees at less than the applicable predetermined rate for the work performed until an acceptable program is approved.

- (3) Equal employment opportunity. The utilization of apprentices, trainees, and journeymen under this clause shall be in conformity with the equal employment opportunity requirements of Executive Order 11246, as amended, and 29 CFR Part 30.
- (e) Compliance with Copeland Act requirements. The Contractor shall comply with the requirements of 29 CFR Part 3, which are hereby incorporated by reference in this contract.
- (f) Contract termination; debarment. A breach of this contract clause may be grounds for termination of the contract and for debarment as a Contractor and a subcontractor as provided in 29 CFR 5.12.
- (g) Compliance with Davis-Bacon and related Act requirements. All rulings and interpretations of the Davis-Bacon and related Acts contained in 29 CFR Parts 1, 3, and 5 are herein incorporated by reference in this contract.
- (h) Disputes concerning labor standards. Disputes arising out of the labor standards provisions of this clause shall not be subject to the general disputes clause of this contract. Such disputes shall be resolved in accordance with the procedures of the Department of Labor set forth in 29 CFR Parts 5, 6, and 7. Disputes within the meaning of this clause include disputes between the Contractor (or any of its subcontractors) and the PHA, HUD, the U.S. Department of Labor, or the employees or their representatives.
- (i) Certification of eligibility.
 - (1) By entering into this contract, the Contractor certifies that neither it (nor he or she) nor any person or firm who has an interest in the Contractor's firm is a person or firm ineligible to be awarded contracts by the United States Government by virtue of section 3(a) of the Davis-Bacon Act or 29 CFR 5.12(a)(1).

(2) No part of this contract shall be subcontracted to any person or firm ineligible for award of a United States Government contract by virtue of section 3(a) of the Davis-Bacon Act or 29 CFR 5.12(a)(1).

(3) The penalty for making false statements is prescribed in the U. S. Criminal Code, 18 U.S.C. 1001.

- (j) Contract Work Hours and Safety Standards Act. As used in this paragraph, the terms "laborers" and "mechanics" include watchmen and guards.
 - (1) Overtime requirements. No contractor or subcontractor contracting for any part of the contract work which may require or involve the employment of laborers or mechanics, including watchmen and guards, shall require or permit any such laborer or mechanic in any workweek in which the individual is employed on such work to work in excess of 40 hours in such workweek unless such laborer or mechanic receives compensation at a rate not less than one and one-half times the basic rate of pay for all hours worked in excess of 40 hours in such workweek.
 - (2) Violation; liability for unpaid wages; liquidated damages. In the event of any violation of the provisions set forth in subparagraph (j)(1) of this clause, the Contractor and any subcontractor responsible therefor shall be liable for the unpaid wages. In addition, such Contractor and subcontractor shall be liable to the United States (in the case of work done under contract for the District of Columbia or a territory, to such District or to such territory), for liquidated damages. Such liquidated damages shall be computed with respect to each individual laborer or mechanic (including watchmen and guards) employed in violation of the provisions set forth in subparagraph (j)(1) of this clause, in the sum of \$27 for each calendar day on which such individual was required or permitted to work in excess of the standard workweek of 40 hours without payment of the overtime wages required by provisions set forth in subparagraph (j)(1) of this clause. DOL posts current fines at: <https://www.dol.gov/whd/govcontracts/cwhssa.htm#cmp>
 - (3) Withholding for unpaid wages and liquidated damages. HUD or its designee shall upon its own action or upon written request of an authorized representative of the Department of Labor withhold or cause to be withheld, from any moneys payable on account of work performed by the Contractor or subcontractor under any such contract or any Federal contract with the same prime Contractor, or any other Federally-assisted contract subject to the Contract Work Hours and Safety Standards Act, which is held by the same prime Contractor, such sums as may be determined to be necessary to satisfy any liabilities of such Contractor or subcontractor for unpaid wages and liquidated damages as provided in the provisions set forth in subparagraph (j)(2) of this clause.
- (k) Subcontracts. The Contractor or subcontractor shall insert in any subcontracts all the provisions contained in this clause, and such other clauses as HUD or its designee may by appropriate instructions require, and also a clause requiring the subcontractors to include these provisions in any lower tier subcontracts. The prime Contractor shall be responsible for the compliance by any subcontractor or lower tier subcontractor with all these provisions.

47. Non-Federal Prevailing Wage Rates

(a) Any prevailing wage rate (including basic hourly rate and any fringe benefits), determined under State or tribal law to be prevailing, with respect to any employee in any trade or position employed under the contract, is inapplicable to the contract and shall not be enforced against the Contractor or any subcontractor, with respect to employees engaged under the contract whenever such non-Federal prevailing wage rate exceeds:

(1) The applicable wage rate determined by the Secretary of Labor pursuant to the Davis-Bacon Act (40 U.S.C. 3141 et seq.) to be prevailing in the locality with respect to such trade;

(b) An applicable apprentice wage rate based thereon specified in an apprenticeship program registered with the U.S. Department of Labor (DOL) or a DOL-recognized State Apprenticeship Agency; or

(c) An applicable trainee wage rate based thereon specified in a DOL-certified trainee program.

48. Procurement of Recovered Materials.

(a) In accordance with Section 6002 of the Solid Waste Disposal Act, as amended by the Resource Conservation and Recovery Act, the Contractor shall procure items designated in guidelines of the Environmental Protection Agency (EPA) at 40 CFR Part 247 that contain the highest percentage of recovered materials practicable, consistent with maintaining a satisfactory level of competition. The Contractor shall procure items designated in the EPA guidelines that contain the highest percentage of recovered materials practicable unless the Contractor determines that such items: (1) are not reasonably available in a reasonable period of time; (2) fail to meet reasonable performance standards, which shall be determined on the basis of the guidelines of the National Institute of Standards and Technology, if applicable to the item; or (3) are only available at an unreasonable price.

() Paragraph (a) of this clause shall apply to items purchased under this contract where: (1) the Contractor purchases in excess of \$10,000 of the item under this contract; or (2) during the preceding Federal fiscal year, the Contractor: (i) purchased any amount of the items for use under a contract that was funded with Federal appropriations and was with a Federal agency or a State agency or agency of a political subdivision of a State; and (ii) purchased a total of in excess of \$10,000 of the item both under and outside that contract.



HUD INFORMATION BULLETIN 90-23

Page 1 of 2

1. NOTICE AND ASSISTANCE REGARDING PATENT AND COPYRIGHT INFRINGEMENT

- a. The Contractor shall report to the Contracting Officer, promptly and in reasonable written detail, each notice or claim of patent or copyright infringement based on the performance of this contract of which the Contractor has knowledge.
- b. In the event of any claim or suit against the SNRHA on account of any alleged patent or copyright infringement arising out of the performance of this contract or out of the use of any supplies furnished or work or services performed under this contract, the Contractor shall furnish to the SNRHA, when requested by the Contracting Officer, all evidence and information in possession of the contractor pertaining to such suit or claim. Such evidence and information shall be furnished at the expense of the SNRHA except where the contractor has agreed to indemnify the SNRHA.
- c. The Contractor agrees to include, and require inclusion of, this clause in all subcontracts at any tier for supplies or services (including construction and architects-engineer subcontracts) and those for material, expected to exceed the Small Purchases threshold.

2. CLEAN AIR AND WATER CERTIFICATION

The Contractor certifies that:

- a. Any facility to be used in the performance of this proposed contract is _____ / is not _____ listed on the Environmental Protection Agency List of Violating Facilities;
- b. The Offeror will immediately notify the Contracting Officer, before award, of the receipt of any communication for the Administrator, or a designee, or the Environmental Protection Agency, indicating that any facility that the Offeror proposed to use for the performance of the contract is under consideration to be listed on the EPA List of Violating Facilities; and
- c. The Contractor will include a certification substantially the same as this certification, including this paragraph (c) in every nonexempt subcontract.

3. CLEAN AIR AND WATER

"Air Act," as used in this clause, means the Clean Air Act (42 U.S.C. 7401 et seq.).

"Clean Air standards," as used in this clause, means:

- (1) Any enforceable rules, regulations, guidelines, standards, limitations, orders, controls, prohibitions, work practices, or other requirements combined in, issued under, or otherwise adopted under the Air Act or Executive Order 11738.
- (2) An applicable implementation plan as described in Section 1109d of the Air Act (41 U.S.C. 7401d)
- (3) An approved implementation procedure or plan under section 111(c) or section 111(d) of the Air Act (42 U.S.C. 7411(c) or (d)); or
- (4) An approved implementation procedure under section 1129(d) of the Air Act (42 U.S.C. 7412(d))



HUD INFORMATION BULLETIN 90-23

Page 2 of 2

"Clean water standards," as used in this clause, means any enforceable limitation, control, condition, prohibition, standard, or other requirement promulgated under the Water Act or contained in a permit issued to a discharger by the Environmental Protection Agency or by a State under an approved program, as authorized by section 402 of the Water Act (33 U.S.C.1342), or by local government to ensure compliance with pretreatment regulations as required by section 307 of the Water Act (33 U.S.C. 1317)

"Compliance," as used in this clause, means compliance with:

- (1) Clean air or water standards; or
- (2) A schedule or plan ordered or approved by a court of competent jurisdiction, the Environmental Protection Agency, or an air or water pollution control agency under the requirements of the Air Act or Water Act and related regulations.

"Facility," as used in this clause, means any building, plant, installation, structure, mine, vessel or other floating craft, location, or site of operations, owned, leased, or supervised by a Contractor or subcontract, used in the performance of a contract or subcontract. When a location or site shall be deemed a facility except when the Administrator, or a designee, or the Environmental Protection Agency, determines that independent facilities are co-located in one geographical area.

"Water Act," as used in this clause, means Clean Water Act (33 U.S.C. 1251 et seq.).

b. The Contractor agrees:

- (1) To comply with all the requirements of section 114 of the Clean Air Act (42 U.S.C. 7414) and section 308 of the Clean Water Act (33 U.S.C. 1318) relating to inspection, monitoring, entry, reports, and information, as well as other requirement specified in section 114 and section 308 of the Air Act and the Water Act, and all regulations and guidelines issued to implement those acts before the award of this contract;
- (2) That no portion of the work as required by this prime contract will be performed in a facility listed on the Environmental Protection Agency List of Violating Facilities on the date when this contract was awarded unless and until the EPA eliminates the name of the facility from the listing;
- (3) To use best efforts to comply with clean air standards and clean water standards at the facility in which the contract is being performed; and
- (4) To insert the substance of this clause into any nonexempt subcontract, including this subparagraph(b)(4).

4. ENERGY POLICY AND CONSERVATION ACT

The Contractor must meet the mandatory energy efficiency standards as required by the Energy Policy and Conservation Act (Pub.L.94-16). The "Covered product" shall meet the highest energy efficiency requirements in accordance with industry performance standards. "Covered product" means a consumer product such as central air conditions, freezers, furnaces, and water heaters. Copies of standards can be obtained from the list identified in the SNRHA's project manual, dated December 1989, page 01090-4 under the trade association names and titles section.

Davis-Bacon Key Points

1. The Davis-Bacon Act is the federal regulation regarding wage rates that must be paid on projects that include federal funds. The Davis-Bacon Act was enacted in 1931 and it applies to contracts in excess of \$2,000.00. As this project is funded with federal funds you must follow federal Davis-Bacon regulations not State regulations therefore “Prevailing Wages” do not apply here.
2. Wage Determination:
 - a. Must be posted at the job site in plain view, in an easily accessible area, so all employees working on the project have access to it.
 - b. Should you have need of a classification that is not listed on the wage determination then an Additional Classification Request must be submitted for DOL approval. Should the DOL not approve the rate listed and determines a higher rate must be paid then the contractor will be responsible for the difference in pay retroactive back to the first day work was performed under this classification. The SNRHA will not reimburse the contractor for this cost. The Additional Classification Request must also be posted on the job site in an easily accessible area so the employees working under this classification will be aware of the wage rate to be paid for their classification.
 - c. The Construction Inspector for this project will be conducting Employee Interviews so the employees need to know their correct classification and their rate of pay. The Inspector may even ask to see their paystubs so they should have that as well.
3. Certified Payroll Reports:
 - a. Must be submitted EVERY week beginning one week after the project starts.
 - b. Certified payroll reports require an original, “wet” signature to be valid therefore certified payroll reports may not be emailed or faxed in.
 - c. Certified payroll reports are to be signed by the Owner, President, CEO or CFO of the company. If the company wants anyone other than the Owner, President, CEO or CFO of the company to sign their certified payroll reports then an Authorization to Sign Form listing who is authorized to sign the certified payroll reports must be submitted and that form must be signed by the Owner, President, CEO or CFO of the company to be valid.

- d. You must have your certified payroll reports submitted up to point of billing. If your certified payroll reports are not received it could hold up the processing of your payment.
 - e. Supervisors, Foreman, Journeyman classifications are not recognized by the Department of Labor (DOL). So they must be listed simply as the classification for the work they are performing.
 - f. If you have Supervisors or Superintendents who only supervise (they do not do any physical work on the project) then they should not be listed on your certified payroll reports. But if they are working on the project and they spend at least 20% of their time for the work week working on this project then they must be listed on the payroll as whatever work they are performing.
 - g. If the Owner of the company is working on the project then he also must be listed on the certified payroll reports as whatever classification they're working under and they also must listed as "Owner" under their classification. They need to show hours worked but they do NOT have to list the pay they received unless they are the only one working on the project. If so then they MUST list what they earned on this project.
 - h. If your employees have any deductions to their pay other than Federal Taxes, Social Security or Medicare then a deduction authorization form, signed and dated by the employee, listing what each deduction is for, the exact amount of the deduction and the time frame the deduction is taken (hourly, weekly, monthly, etc.) must be submitted for our records.
 - i. An Employee List must be submitted with each contractor and subcontractors certified payroll reports. The Employee List must detail each employee's full name, complete Social Security Number, complete mailing address and a good contact phone number for every employee working on the project.
4. If you have apprentices working on the project they must be enrolled in a bonafied, state approved apprenticeship program and documentation to that affect must be submitted with the first certified payroll report that the apprentice appears on.

A copy of the Wage Determination, Additional Classification Request Form and WH347 Payroll Form were included in your bid documents. Should you ever have any questions regarding your certified payroll reports please feel free to contact me.

PAYROLL

(For Contractor's Optional Use; See Instructions at www.dol.gov/whd/forms/wh347instr.htm)



Rev. Dec. 2008

Persons are not required to respond to the collection of information unless it displays a currently valid OMB control number.

OMB No.: 1215-0149
Expires: 12/31/2011

NAME OF CONTRACTOR OR SUBCONTRACTOR ADDRESS

PAYROLL NO. FOR WEEK ENDING PROJECT AND LOCATION PROJECT OR CONTRACT NO.

(1) NAME AND INDIVIDUAL IDENTIFYING NUMBER (e.g., LAST FOUR DIGITS OF SOCIAL SECURITY NUMBER) OF WORKER	(2) NO. OF WITH-HOLDING EXEMPTIONS	(3) WORK CLASSIFICATION	OT. OR ST.	(4) DAY AND DATE							(5) TOTAL HOURS	(6) RATE OF PAY	(7) GROSS AMOUNT EARNED	(8) DEDUCTIONS					(9) NET WAGES PAID FOR WEEK
				HOURS WORKED EACH DAY										FICA	WITH- HOLDING TAX	OTHER	TOTAL DEDUCTIONS		
			O																
			S																
			O																
			S																
			O																
			S																
			O																
			S																
			O																
			S																
			O																
			S																
			O																
			S																

While completion of Form WH-347 is optional, it is mandatory for covered contractors and subcontractors performing work on Federally financed or assisted construction contracts to respond to the information collection contained in 29 C.F.R. §§ 3.3, 5.5(a). The Copeland Act (40 U.S.C. § 3145) contractors and subcontractors performing work on Federally financed or assisted construction contracts to "furnish weekly a statement with respect to the wages paid each employee during the preceding week." U.S. Department of Labor (DOL) regulations at 29 C.F.R. § 5.5(a)(3)(ii) require contractors to submit weekly a copy of all payrolls to the Federal agency contracting for or financing the construction project, accompanied by a signed "Statement of Compliance" indicating that the payrolls are correct and complete and that each laborer or mechanic has been paid not less than the proper Davis-Bacon prevailing wage rate for the work performed. DOL and federal contracting agencies receiving this information review the information to determine that employees have received legally required wages and fringe benefits.

Public Burden Statement

We estimate that it will take an average of 55 minutes to complete this collection, including time for reviewing instructions, searching existing data sources, gathering and maintaining the data needed, and completing and reviewing the collection of information. If you have any comments regarding these estimates or any other aspect of this collection, including suggestions for reducing this burden, send them to the Administrator, Wage and Hour Division, U.S. Department of Labor, Room S3502, 200 Constitution Avenue, N.W. Washington, D.C. 20210

Date _____

I, _____ (Name of Signatory Party) _____ (Title)

do hereby state:

(1) That I pay or supervise the payment of the persons employed by

_____ on the _____ (Contractor or Subcontractor) _____; that during the payroll period commencing on the _____ (Building or Work) _____ day of _____, _____, and ending the _____ day of _____, _____, all persons employed on said project have been paid the full weekly wages earned, that no rebates have been or will be made either directly or indirectly to or on behalf of said

_____ from the full _____ (Contractor or Subcontractor) _____ weekly wages earned by any person and that no deductions have been made either directly or indirectly from the full wages earned by any person, other than permissible deductions as defined in Regulations, Part 3 (29 C.F.R. Subtitle A), issued by the Secretary of Labor under the Copeland Act, as amended (48 Stat. 948, 63 Stat. 108, 72 Stat. 967; 76 Stat. 357; 40 U.S.C. § 3145), and described below:

(2) That any payrolls otherwise under this contract required to be submitted for the above period are correct and complete; that the wage rates for laborers or mechanics contained therein are not less than the applicable wage rates contained in any wage determination incorporated into the contract; that the classifications set forth therein for each laborer or mechanic conform with the work he performed.

(3) That any apprentices employed in the above period are duly registered in a bona fide apprenticeship program registered with a State apprenticeship agency recognized by the Bureau of Apprenticeship and Training, United States Department of Labor, or if no such recognized agency exists in a State, are registered with the Bureau of Apprenticeship and Training, United States Department of Labor.

(4) That:

(a) WHERE FRINGE BENEFITS ARE PAID TO APPROVED PLANS, FUNDS, OR PROGRAMS

— in addition to the basic hourly wage rates paid to each laborer or mechanic listed in the above referenced payroll, payments of fringe benefits as listed in the contract have been or will be made to appropriate programs for the benefit of such employees, except as noted in section 4(c) below.

(b) WHERE FRINGE BENEFITS ARE PAID IN CASH

— Each laborer or mechanic listed in the above referenced payroll has been paid, as indicated on the payroll, an amount not less than the sum of the applicable basic hourly wage rate plus the amount of the required fringe benefits as listed in the contract, except as noted in section 4(c) below.

(c) EXCEPTIONS

EXCEPTION (CRAFT)	EXPLANATION

REMARKS:

NAME AND TITLE	SIGNATURE
----------------	-----------

THE WILLFUL FALSIFICATION OF ANY OF THE ABOVE STATEMENTS MAY SUBJECT THE CONTRACTOR OR SUBCONTRACTOR TO CIVIL OR CRIMINAL PROSECUTION. SEE SECTION 1001 OF TITLE 18 AND SECTION 231 OF TITLE 31 OF THE UNITED STATES CODE.

How to Correctly Fill Out a WH-347 Payroll Form

The completion of the WH-347 Payroll Form is optional; contractors may utilize their own payroll system as long as it conforms to the WH-347 Payroll Form and contains all the necessary information. If you utilize WH-347 Payroll Form as a pdf, saving it electronically aids in making any needed corrections.

Check one of the boxes and list name of contractor or subcontractor

The last day of the payroll period.

Fill out completely with contractor or subcontractor address

U.S. Department of Labor
Employment Standards Administration
Wage and Hour Division

PAYROLL
(For Contractor's Optional Use; See Instructions at www.dol.gov/esa/whd/forms/wh347instr.htm)
Persons are not required to respond to the collection of information unless it displays a currently valid OMB control number.

U.S. Wage and Hour Division
Rev. Dec. 2008

NAME OF CONTRACTOR OR SUBCONTRACTOR

Sample Construction Company

ADDRESS 385 West Drive, Madison WI 53703

OMB No. 1215-0149
Expires: 12/31/2011

PAYROLL NO
8

FOR WEEK ENDING
04/24/2010

PROJECT AND LOCATION
Robin Street Apartments, Delafield WI 53018

PROJECT OR CONTRACT NO.
3000

(1) NAME AND INDIVIDUAL IDENTIFYING NUMBER (e.g., LAST FOUR DIGITS OF SOCIAL SECURITY NUMBER OF WORKER)	(2) NO. OF EMPLOYERS-EXEMPTIONS	(3) WORK CLASSIFICATION	(4) DAY AND DATE							(5) TOTAL HOURS	(6) RATE OF PAY	(7) GROSS AMOUNT EARNED	(8) DEDUCTIONS					(9) NET WAGES PAID FOR WEEK		
			Mon	Tue	Wed	Thu	Fri	Sat	Sun				FICA	WITH-HOLDING TAX	State with-holding tax	Medicare	OTHER		TOTAL DEDUCTIONS	
			18	19	20	21	22	23	24				HOURS WORKED EACH DAY							
Alex Driver - #####	2	Power Equipment Operator Bull Dozer Group						2.00		2.00			\$1,422.84	\$161.00	\$185.15	\$156.97	\$50.31	\$85.00	\$2,121.43	\$1,374.03
					9.00	8.00	3.50	6.00		27.50			\$2,012.46							

Payrolls must be numbered sequentially and should be based on the weeks worked under a contract.

Type the word "Final" when the last payroll is submitted for the project.

Indicate the days and dates of the pay period. (should match week ending directly above)

The name and location of project.

The prime contractor should include the project number as listed in the loan

List each worker's name.

Only laborers and mechanics performing construction work under the contract should be listed.

Please note: Business Owners need only include their name, work classification including "owner" and the daily total hours worked.

Specify the job classification located in the contract wage decision and/or the corresponding job title.

List hourly wage rate and fringes paid in cash (not those paid to plans)



Specify the net amount paid to the employee for the pay

(For Contractor's Optional Use; See Instructions at www.dol.gov/esa/whd/forms/wh347instr.htm)

Persons are not required to respond to the collection of information unless it displays a currently valid OMB control number.

Company Name: _____ ADDRESS: 385 West Drive, Madison WI 53703

FOR WEEK ENDING: 04/23/2010 PROJECT AND LOCATION: Robin Street Apartments, Delafield WI 53018 PROJECT OR CONTRACT NUMBER: 3000

NAME AND INDIVIDUAL IDENTIFYING NUMBER (e.g., LAST FOUR DIGITS OF SOCIAL SECURITY NUMBER OF WORKER)	NO. OF EMPLOYER EMPLOYEES	WORK CLASSIFICATION	(4) DAY AND DATE							(5) TOTAL HOURS	(6) RATE OF PAY	(7) GROSS AMOUNT EARNED	(8) DEDUCTIONS				TOTAL DEDUCTIONS	NET WAGES PAID FOR WEEK
			Sun	Mon	Tue	Wed	Thu	Fri	Sat				FICA	WITHH.				
			18	19	20	21	22	23	24									
Alex Driver - #####	2	Power Equipment Bull Dozer Group 2						2.00	2.00	\$62.83	\$1,422.84	\$161.00				\$538.43	\$1,374.03	
Jason Worker - #####	2	General Laborer						4.00	4.00	\$19.25	\$77.00	\$136.06				\$47.71	\$1,233.07	
Shawn Worker - #####	3	Carpenter						1.50	1.50	\$60.19	\$90.28	\$121.00	\$121.00	\$128.35	\$47.19	\$47.19	\$1,406.18	
		Apprentice Carpenter 1st 6 mo. at 40%						40.00	40.00	\$30.52	\$1,220.80	\$85.18	\$105.41	\$90.50	\$26.62	\$307.71	\$757.01	
		Plumber						20.00	20.00	\$67.88	\$1,357.60							
Roy Wrench - #####	5	Steamfitter						20.00	20.00	\$69.13	\$1,382.60	\$163.46	\$147.11	\$118.51	\$51.08	\$480.16	\$1,563.04	
Bart Turner - #####	1	Power Equipment Rotary Drill Group 4						24.00	24.00	\$60.80	\$1,459.20	\$112.00	\$142.48	\$122.33	\$35.98	\$415.93	\$1,023.27	

Must accurately reflect overtime and straight time hours worked under the contract.

Specify the total overtime and straight time hours worked on the project.

Specify the gross earnings for the hours worked under the contract.

While completion of Form WH-347 is optional, it is mandatory for covered contractors and subcontractors performing work on Federally financed or assisted construction contracts to respond to (40 U.S.C. § 3145) contractors and subcontractors performing work on Federally financed or assisted construction contracts to furnish weekly a statement with respect to the wages paid each week. 29 C.F.R. § 5.5(a)(3)(ii) require contractors to submit weekly a copy of all payrolls to the Federal agency contracting for or financing the construction project, accompanied by a signed "Statement of Compliance" certifying that the wages paid are not less than the proper Davis-Bacon prevailing wage rate for the work performed. DOL and federal contracting agencies receiving this information review the information for compliance with the Davis-Bacon Act.

Public Burden Statement

This estimate that we will take no action if you fail to complete this collection. It includes time for reviewing instructions, searching existing data sources, gathering and maintaining the data needed, and reviewing and reporting the collection of information. If you have comments on this estimate that you would like to submit to the Office of Management and Budget, Paperwork Project Director, Washington, DC 20503, you should submit them by February 1, 2010.

If part of a worker's weekly wage was earned on projects other than the project described on this payroll, enter the gross amount earned on this contract in the top half of column 7. Enter the gross amount earned during the week for all projects in the bottom half.

Alex Driver worked 29.5 hours on this contract and 12.5 hours on another contract. The gross wages earned on this project, \$1,422.84, is entered in the top half of column 7. The gross wages earned on all projects, \$2,012.46, is entered in the

(1) NAME AND INDIVIDUAL IDENTIFYING NUMBER (e.g., LAST FOUR DIGITS OF SOCIAL SECURITY NUMBER OF WORKER)	(2) NO OF EXEMPTIONS	(3) WORK CLASSIFICATION	(4) DAY AND DATE							TOTAL HOURS	RATE OF PAY	GROSS AMOUNT EARNED		DEDUCTIONS					TOTAL DEDUCTIONS	NET WAGES PAID FOR WEEK
			Sun	Mon	Tue	Wed	Thu	Fri	Sat			TOTAL GROSS AMOUNT EARNED	FICA	WITH- HOLDING TAX	State with- holding tax	Medicare	OTHER			
			18	19	20	21	22	23	24											
Alex Driver - #####	2	Power Equipment Bull Dozer Group 2						2.00		2.00	\$62.83	\$1,422.84		\$185.15	\$156.97	\$50.31	\$85.00	\$638.43	\$1,374.03	
					8.00			3.50	8.00	27.50	\$73.20	\$2,012.46								
Jason Worker - #####	2	General Laborer							4.00	4.00	\$170.78	\$1,700.78		\$156.47	\$132.66	\$42.52		\$467.71	\$1,233.07	
				8.00	8.00	8.00	8.00	8.00		40.00	\$170.78	\$1,700.78								
Sharon Wood - #####	3	Carpenter						1.50		1.50	\$60.19	\$1,887.49		\$154.77	\$128.35	\$47.19		\$481.31	\$1,406.18	
				8.00	8.00	8.00	8.00	8.00		40.00	\$30.52	\$1,887.49								
Reggie Tree - #####	1	Apprentice Carpenter 1st 6 mo at 40%								40.00	\$32.72	\$1,064.72		\$105.41	\$90.50	\$26.62		\$307.71	\$757.01	
				8.00	8.00	8.00	8.00	8.00		40.00	\$12.21	\$1,064.72								
Roy Wrench - #####	5	Plumber							4.00	4.00	\$67.88	\$1,004.80								
				8.00					4.00	20.00	\$35.28	\$1,004.80								
Roy Wrench - #####	5	Steamfitter							4.00	4.00	\$69.13	\$1,038.40		\$147.11	\$118.51	\$51.08		\$480.16	\$1,563.04	
				8.00	8.00			4.00		20.00	\$34.41	\$2,043.20								
Bart Turner - #####	1	Power Equipment Rotary Drill Group 4							8.00	8.00	\$60.80	\$719.28		\$142.48	\$122.33	\$35.98		\$315.53	\$1,023.27	
				8.00	8.00				8.00	24.00	\$29.97	\$1,439.20								

If an employee performs multiple work classifications under the contract, use two or more lines to distinguish the different job classifications, hours worked, and hourly wage earned for each.

Combine the two classifications when recording the gross amount earned for this pay period, deductions, and net wages.

A registered apprentice performing work under a contract must be reported. The payroll must include the current pay scale & provide a copy of the apprenticeship agreement.

PAYROLL
 Optional Use; See instructions at www.dol.gov/esa/whd/forms/wh347

Provide explanation of "other" deductions on signatory page.



Address: 385 West Drive, Madison WI 53703
 PROJECT AND LOCATION: Robin Street Apartments, Delafield WI 53018
 PROJECT OR CONTRACT NO: 3000
 Expires: 12/31/2011

(1) NAME AND INDIVIDUAL IDENTIFYING NUMBER (e.g., LAST FOUR DIGITS OF SOCIAL SECURITY NUMBER OF WORKER)	(2) NO. OF DAYS EXEMPTED	(3) WORK CLASSIFICATION	(4) DAY AND DATE							(5) TOTAL HOURS	(6) RATE OF PAY	(7) GROSS AMOUNT EARNED	(8) DEDUCTIONS					(9) NET WAGES PAID FOR WEEK	
			Sun	Mon	Tue	Wed	Thu	Fri	Sat				FICA	WITH-HOLDING TAX	State with-holding tax	Medicare	OTHER		TOTAL DEDUCTIONS
			18	19	20	21	22	23	24										
Alex Driver - #####	2	Power Equipment Bull Dozer Group 2						2.00	2.00	\$62.83	\$1,422.84	\$161.00	\$185.15	\$156.97	\$50.31	\$85.00	\$638.43	\$1,374.03	
Jason Worker - #####	2	General Laborer			8.00	8.00	5.00	6.00	4.00	\$49.20	\$1,700.78	\$136.06	\$156.47	\$132.66	\$42.52		\$467.71	\$1,233.07	
Sharon Wood - #####	3	Carpenter						1.50	1.50	\$60.19	\$1,887.49	\$151.00	\$154.77	\$128.35	\$47.19		\$481.31	\$1,406.18	
Reggie Tree - #####	1	Apprentice Carpenter 1st 6 mo. at 40%			8.00	8.00	8.00	8.00	40.00	\$32.72	\$1,064.72	\$85.18	\$105.41	\$90.50	\$26.62		\$307.71	\$757.01	
Roy Wrench - #####	5	Plumber						4.00	20.00	\$67.88	\$1,004.80								
Roy Wrench - #####	5	Steamfilter			8.00	8.00	4.00		20.00	\$69.13	\$1,038.40	\$163.46	\$147.11	\$118.51	\$51.08		\$480.16	\$1,563.04	
Bart Turner - #####	1	Power Equipment Rotary Drill Group 4			8.00	8.00		8.00	24.00	\$60.80	\$719.28	\$115.14	\$142.48	\$122.33	\$35.98		\$415.93	\$1,023.27	

Fringe benefits are not paid as cash to Bart Turner: explanation is included under "(c) exceptions" on signatory page.

While completion of Form 40 U.S.C. § 3145) certifies that the contractor or mechanic has been paid...

For generally financed or assisted construction contracts to respond to the information collection contained in 29 C.F.R. §§ 3.2, 6.5(a). The Copeland Act requires the contractor or financing the construction project, accompanied by a signed "Statement of Compliance" indicating that the payrolls are correct and complete and that each laborer or subcontracting agencies receiving this information review the information to determine that employees have received legally required wages and fringe benefits.

We estimate that it will take approximately 15 minutes to search existing data sources, gathering and maintaining the data needed, and completing and reviewing the collection of information. If you have any comments regarding these estimates or any other aspect of this collection, including suggestions for reducing this burden, send them to the Administrator, Wage and Hour Division, ESA, U.S. Department of Labor, Room 33502, 200 Constitution Avenue, N.W. Washington, D.C. 20210

Date 04/28/2010

I, Tiffany Payer Payroll Supervisor
(Name of Signatory Party) (Title)

do hereby state:

(1) That I pay or supervise the payment of the persons employed by
Sample Construction Company on the
(Contractor or Subcontractor)
Robin Street Apartments, Delafield WA; that during the payroll period commencing on the
(Building or Work)
18 day of 4, 2010, and ending the 24 day of 4, 2010,
all persons employed on said project have been paid the full weekly wages earned, that no rebates have
been or will be made either directly or indirectly to or on behalf of said
Sample Construction Company
(Contractor or Subcontractor)

weekly wages earned by any person and that no deductions have been made either directly or indirectly
from the full wages earned by any person, other than permissible deductions as defined in Regulations, Part
3 (29 C.F.R. Subtitle A), issued by the Secretary of Labor under the Copeland Act, as amended (48 Stat. 948,
63 Stat. 108, 72 Stat. 967; 76 Stat. 357; 40 U.S.C. § 3145), and described below:

Alex Driver - ##### - other deductions - \$55 for child support

Explanation of "other"

(2) That any payrolls otherwise under this contract required to be submitted for the above period are
correct and complete; that the wage rates for laborers or mechanics contained therein are not less than the
applicable wage rates contained in any wage determination incorporated into the contract; that the
classifications set forth therein for each laborer or mechanic conform with the work he performed.

(3) That any apprentices employed in the above period are duly registered in a bona fide
apprenticeship program registered with a State apprenticeship agency recognized by the Bureau of
Apprenticeship and Training, United States Department of Labor, or if no such recognized agency exists in a
State, are registered with the Bureau of Apprenticeship and Training, United States Department of Labor.

(4) That:

(a) WHERE FRINGE BENEFITS ARE PAID TO APPROVED PLANS, FUNDS, OR PROGRAMS

- In addition to the basic hourly wage rates paid to each laborer or mechanic listed in
the above referenced payroll, payments of fringe benefits as listed in the contract
have been or will be made to appropriate programs for the benefit of such
employees, except as noted in section 4(c) below.

(b) WHERE FRINGE BENEFITS ARE PAID IN CASH

- Each laborer or mechanic listed in the above referenced payroll has been paid,
as indicated on the payroll, an amount not less than the sum of the applicable
basic hourly wage rate plus the amount of the required fringe benefits as listed
in the contract, except as noted in section 4(c) below.

(c) EXCEPTIONS

EXCEPTION (CRAFT)	EXPLANATION
Power Equipment Rotary Drill Group 4	paid directly to plan: health & dental at \$12.50 per hour and Pension at \$6.25 per hour
REMARKS	
NAME AND TITLE Robert Sample, Owner	SIGNATURE
THE WILLFUL FALSIFICATION OF ANY OF THE ABOVE STATEMENTS MAY SUBJECT THE CONTRACTOR OR SUBCONTRACTOR TO CIVIL OR CRIMINAL PROSECUTION. SEE SECTION 1601 OF TITLE 18 AND SECTION 331 OF TITLE 41 OF THE UNITED STATES CODE.	

Explanation of exception to fringe benefits

**U.S. DEPARTMENT OF HOUSING AND URBAN DEVELOPMENT
REPORT OF ADDITIONAL CLASSIFICATION AND RATE**

HUD FORM 4230A

OMB Approval Number 2501-0011
(Exp. 01/31/2010)

1. FROM (name and address of requesting agency)	2. PROJECT NAME AND NUMBER
	3. LOCATION OF PROJECT (City, County and State)

4. BRIEF DESCRIPTION OF PROJECT	5. CHARACTER OF CONSTRUCTION <input type="checkbox"/> Building <input type="checkbox"/> Residential <input type="checkbox"/> Heavy <input type="checkbox"/> Other (specify) <input type="checkbox"/> Highway
---------------------------------	---

6. WAGE DECISION NO. (include modification number, if any) <input type="checkbox"/> COPY ATTACHED	7. WAGE DECISION EFFECTIVE DATE
--	---------------------------------

8. WORK CLASSIFICATION(S)	HOURLY WAGE RATES	
	BASIC WAGE	FRINGE BENEFIT(S) (if any)

9. PRIME CONTRACTOR (name, address)	10. SUBCONTRACTOR/EMPLOYER, IF APPLICABLE (name, address)
-------------------------------------	---

Check All That Apply:

- The work to be performed by the additional classification(s) is not performed by a classification in the applicable wage decision.
- The proposed classification is utilized in the area by the construction industry.
- The proposed wage rate(s), including any bona fide fringe benefits, bears a reasonable relationship to the wage rates contained in the wage decision.
- The interested parties, including the employees or their authorized representatives, agree on the classification(s) and wage rate(s).
- Supporting documentation attached, including applicable wage decision.

Check One:

- Approved, meets all criteria. DOL confirmation requested.**
- One or more classifications fail to meet all criteria as explained in agency referral. DOL decision requested.**

<div style="display: flex; justify-content: space-between;"> <div style="width: 45%; text-align: center;"> <p>_____</p> <p>Agency Representative (Typed name and signature)</p> </div> <div style="width: 45%; text-align: center;"> <p>_____</p> <p>Date</p> </div> </div> <div style="display: flex; justify-content: center; margin-top: 20px;"> <p>_____</p> <p>Phone Number</p> </div>	<p>FOR HUD USE ONLY LR2000:</p> <p>Log in:</p> <p>Log out:</p>
--	--



SOUTHERN NEVADA REGIONAL HOUSING AUTHORITY
340 N. 11TH STREET SUITE 150
LAS VEGAS, NV 89101-3611

EMPLOYEE LIST

<u>NAME</u>	<u>FULL SSN</u>	<u>ADDRESS</u>	<u>PHONE</u>
1.			
2.			
3.			
4.			
5.			
6.			
7.			
8.			
9.			
10.			
11.			
12.			
13.			
14.			
15.			

(Contractor)

By: _____

Title: _____



AUTHORIZATION FOR DEDUCTIONS

Plan/Program Name	Plan/Program Type	Deduction Amount	Deduction Interval	Deduction Duration

The undersigned authorizes the above as noted to be deducted from their wages. It is understood that these deductions:

- a.) Are in the interest of me the employee
- b.) Are not a condition of my employment
- c.) Provide no direct or indirect financial benefit accruing to the employer
- d.) Are not otherwise forbidden by law

OR: (Check if applicable)

_____ I certify that I do NOT make any payments to any approved fringe benefit plan, fund or program of any kind

Company Name

Company Representative Signature

Employee Signature

Company Representative Printed Name

Employee Printed Name

Company Representative Title

Date

Date



AUTHORIZATION TO SIGN FOR CONTRACTOR

TO: **SOUTHERN NEVADA REGIONAL HOUSING AUTHORITY**
PROJECT NAME: _____
ADDRESS: _____
IFB / RFQ #: _____
DATE: _____

In connection with the construction of _____

this is to authorize _____

whose official signature appears below, to sign for and in the name of this company, the following documents:

- _____ Schedule of Amounts of Contract Payments
- _____ Progress Schedule
- _____ Periodical Estimates of Partial Payments and Related Paper
- _____ Change Order
- _____ Certified Payroll

Authorized Person's Signature

Authorized Person's Printed Name

Authorized Person's Title

Authorized By Signature

Authorized By Printed Name

Title

Company Name

Subscribed and sworn to before me this _____ day of _____, 20__.

My commission expires: _____

Signature: _____

**EXHIBIT C
CERTIFICATION FOR APPLICABLE FRINGE BENEFIT PAYMENTS**

PROJECT NAME: _____

**Classification/ Fringe
Benefits Provided**

**Name, Address and Telephone Number
of Plan/Fund/Program**

1)

Health & Welfare

Pension

Vacation

Apprenticeship/Training

Other:

2)

Health & Welfare

Pension

Vacation

Apprenticeship/Training

Other:

3)

Health & Welfare

Pension

Vacation

Apprenticeship/Training

Other:

OR: (Check if applicable.)

I certify that I do not make payments to approved fringe benefit plans, funds, or programs.

Contractor/Subcontractor (Name of Firm)

by

Signature

Date

Title



MAR 22 2013

MEMORANDUM NO. 213

TO: ALL CONTRACTING AGENCIES OF THE FEDERAL
GOVERNMENT AND THE DISTRICT OF COLUMBIA

FROM: 
MARY BETH MAXWELL
Acting Deputy Administrator

SUBJECT: Application of the Davis-Bacon and Related Acts requirement that wage rates for additional classifications, when “conformed” to an existing wage determination, bear a “reasonable relationship” to the wage rates in that wage determination

This Memorandum is notification from the Department of Labor’s Wage and Hour Division (WHD) of the proper application of the Davis-Bacon and Related Acts (DBRA) requirements for wage rates for additional classifications that are “conformed” to an existing wage determination by agency contracting officers. The regulations at 29 C.F.R. § 5.5(a)(1)(ii)(A) provide that contracting officers shall approve an additional classification and its proposed wage rate in conformance with an existing wage determination only when the work to be performed by the proposed classification is not performed by a classification in the wage determination and the proposed wage rate bears a “reasonable relationship” to the wages rates in the wage determination. Although this Memorandum primarily focuses on the “reasonable relationship” requirement, it is essential at the threshold to reiterate that a conformance is not appropriate when the work of the proposed classification is already performed by a classification on the wage determination. The conformance process is narrow in scope and has the limited purpose of establishing a new classification when it is necessary to do so because work needed to perform the contract is not performed by an existing classification. *See Cambridge Plaza*, ARB Case No. 07-102 (ARB Oct. 29, 2009). Accordingly, the WHD will not add a new classification through a conformance action unless the first criterion for issuance of a conformance is satisfied, i.e., the proposed work in question is not performed by any classification in the existing wage determination. 29 C.F.R. § 5.5(a)(1)(ii)(A)(1).

In those circumstances in which the duties of the proposed classification are not performed by any classification in the existing wage determination, the WHD will consider whether the proposed wage rate bears a “reasonable relationship” to the wage rates in the wage determination. In the past, WHD has generally approved proposed wage rates for a conformed skilled craft and a power equipment operator when such rates were not less than the rate for the lowest classification in the respective category on the contract wage determination. The practice of using the lowest rate in the relevant category as a benchmark also occurred on occasion with laborers and truck drivers. In keeping with the remedial purpose of the DBRA and the governing

regulations, the wage rate of the lowest skilled craft, laborer, power equipment operator, or truck driver classification on the contract wage determination has no longer been an automatic benchmark when reviewing conformance requests. WHD's approach of not using the lowest wage rate as a benchmark has been progressively implemented over the last year.

The Conformance Process

In accordance with 29 C.F.R. § 5.5(a)(1)(ii)(A), the contracting officer shall require that any class of laborers or mechanics which is not listed in the wage determination and which is to be employed under the contract shall be classified in conformance with the wage determination. The contracting officer shall approve an additional classification and a wage rate (including fringe benefits) for the classification only when the following criteria have been met:

- (1) The work to be performed by the classification requested is not performed by a classification in the wage determination; and
- (2) The classification is utilized in the area by the construction industry; and
- (3) The proposed wage rate, including any bona fide fringe benefits, bears a reasonable relationship to the wage rates contained in the wage determination.

Further, if the contractor, the laborers or mechanics (if known) to be employed in the classification or their representatives, and the contracting agency agree on the classification and wage rate proposed, a report of the action taken is sent by the contracting officer to the Administrator of WHD for approval, denial, or modification. The Administrator (or an authorized representative) shall respond within 30 days of receipt, or the contracting officer will be notified that more time is necessary. *See* 29 C.F.R. § 5.5(a)(1)(ii)(B). In the event that the contractor, the laborers or mechanics (if known) to be employed in the classification or their representatives, and the contracting agency do not agree on the classification and wage rate proposed, the contracting officer shall refer the questions, including the views of all interested parties and the recommendation of the contracting officer, to the Administrator of WHD for determination. The Administrator (or an authorized representative) shall issue a determination within 30 days of receipt and so advise the contracting officer, or the contracting officer will be notified that more time is necessary. *See* 29 C.F.R. § 5.5(a)(1)(ii)(C).

"Reasonable Relationship"

WHD previously typically approved conformance requests from contracting officers for wage rates (including fringe benefits) for skilled classifications and power equipment operators by automatically using as a benchmark the lowest rate for a skilled classification or power equipment operator, respectively, in the applicable wage determination. The practice of using the lowest rate in the relevant category as a benchmark also occurred on occasion with laborers and truck drivers. WHD has concluded, however, that it better reflects the regulatory requirement that "the proposed wage rate, including any bona fide fringe benefits, bears a reasonable relationship to the wage rates contained in the wage determination" to consider the entirety of the rates within the relevant category on the wage determination and to not generally use as a benchmark the lowest rate within that category. The regulation at 29 C.F.R. §

5.5(a)(1)(ii)(A)(3) requires that the proposed wage rate bear a reasonable relationship to the “wage rates” on the wage determination and not to a particular rate or the lowest rate.

The category in which the requested additional classification falls is relevant to the reasonable relationship analysis. As background, classifications in wage determinations fall into four general categories: skilled crafts, laborers, power equipment operators, and truck drivers. To determine a “reasonable relationship,” the requested additional classification is compared to the classifications on the applicable wage determination within the same category. A proposed skilled craft classification is compared to skilled classifications in the wage determination; a proposed laborer classification is compared to existing laborer classifications; a proposed power equipment operator classification is compared to existing power equipment operator classifications; and a proposed truck driver classification is compared to existing truck driver classifications. *See Mistick Construction*, ARB Case No. 02-004 (June 24, 2003); *Tower Construction*, WAB Case No. 94-17 (Feb. 28, 1995).¹ Thus, when considering a conformance request for a skilled classification, WHD generally considers the entirety of the rates for the skilled classifications on the applicable wage determination and looks to where the proposed wage rate falls within the rates listed on the wage determination. Occasionally, however, a wage determination may contain some wage rates for laborer classifications that are higher than some wage rates for the skilled classifications or power equipment operators (likely because the laborers’ rates reflect union prevailing rates and the skilled crafts’ or power equipment operators’ rates reflect weighted average prevailing rates). On such occasions, the contracting officer should look to those skilled classifications whose rates are higher than the laborer classifications’ rates. *See M.Z. Contractors Co.*, WAB Case No. 92-06 (Aug. 25, 1992). If, however, most of the skilled classifications’ or power equipment operators’ rates are lower than the laborer classifications’ rates, then it may be reasonable to propose a rate that reflects the skilled classifications’ rates even if they are lower than the laborer classifications’ rates.

Additionally, whether the wage rates in the applicable category (skilled craft, laborer, power equipment operator, truck driver) in the wage determination are predominantly union prevailing wage rates or predominantly weighted average prevailing wage rates should be considered when proposing rates for an additional classification. For example, if a wage determination contains predominantly union prevailing wage rates for skilled classifications, it typically would be appropriate to look to the union sector skilled classifications in the wage determination and the rates for those classifications when proposing a wage rate for the additional classification. Conversely, if a wage determination contains predominantly weighted average prevailing wage rates for skilled classifications, it typically would be appropriate to look to the weighted average/non-union sector skilled classifications in the wage determination and the rates for those classifications when proposing a wage rate for the additional classification. If the wage rates in the applicable category are roughly half union prevailing rates and half weighted average prevailing rates, it would typically be appropriate to look to the lowest union rate and the highest weighted average rate (assuming the union rates are higher than the weighted average rates) when proposing a wage rate.

¹ Copies of Administrative Review Board (ARB) and Wage Appeals Board (WAB) decisions can be obtained from: www.oalj.dol.gov/libdba.htm.

While the majority of conformance requests are within the skilled classification category, the governing regulations and the principles outlined in this Memorandum apply to the other categories of workers – laborers, power equipment operators, and truck drivers. To meet the “reasonable relationship” test for a conformed power equipment operator or truck driver classification, the proposed wage rate should bear a reasonable relationship to the entirety of rates within the respective classification, and in particular to the union or weighted average rates in the classification (assuming union or weighted average rates prevail for the classification). When a conformance for a laborer classification is requested, WHD generally continues to use the common laborer rate already existing in the wage determination as a benchmark for the proposed rate.

Each conformance request and corresponding wage determination involves particular circumstances and therefore should be evaluated as such. The full range of wage rates on the wage determination for the appropriate category should be reviewed in the manner discussed above. When seeking conformed classifications and wage rates, the contractor and the contracting officer should not rely on a wage determination or conformance granted to another party regardless of the similarity of the work in question. *See, e.g., Inland Waters Pollution Control, Inc.*, WAB Case No. 94-12 (Sept. 30, 1994). Moreover, the contractor and the contracting officer should not prospectively rely on WHD’s prior approval of rates for application to a contract performed at the same location. *See E&M Sales, Inc.*, WAB Case No. 91-17 (Oct. 4, 1991). Although atypical, use of the “lowest skilled” rate may of course be appropriate when that rate in fact bears a reasonable relationship to the wage rates contained in the wage determination for the appropriate category. *See, e.g., Tower Construction*, WAB Case No. 94-17 (Feb. 28, 1995) (conformed wage rate, which equaled lowest skilled rate on wage determination, was reasonable).

In sum, contracting agencies should take the following steps when proposing a wage rate for a classification to be conformed to an existing wage determination:

- First, the contracting agency should determine the category (skilled crafts, laborers, power equipment operators, or truck drivers) of the classification which is being conformed.
- Second, the contracting agency should determine for that category whether union or weighted average/non-union sector rates prevail in the existing wage determination.
- Third, after reviewing the entirety of the rates within the appropriate sector in the applicable category, the contracting agency should determine a rate that bears a reasonable relationship to those rates on the wage determination.
- Fourth, the contracting agency should determine whether any of the considerations identified in this Memorandum apply (or whether any other relevant considerations apply). For example, if the classification being conformed is a skilled classification and some of the wage rates for skilled classifications in the wage determination are lower than the rates for laborer classifications, then the contracting agency should use those existing skilled classification rates that are higher than the laborer rates to determine the

proposed rate. And if the classification which is being conformed is a laborer classification, the proposed wage rate should generally use the existing common laborer wage rate as a benchmark.

Conclusion

The WHD Administrator has historically maintained broad discretion under the regulations to make determinations regarding proposed wage rates for additional classifications that are conformed to existing wage determinations. This broad discretion has been confirmed by the ARB and its predecessors, as illustrated by the decisions cited in this Memorandum, among others. In exercising that discretion, WHD ensures that wage rates (including fringe benefits) for the classification to be conformed bear a reasonable relationship to the range of rates for the classifications in the wage determination in the same category (skilled classifications, power equipment operators, laborers, and truck drivers), and not automatically to the lowest rate in the applicable category. Consistent with the governing regulations, contracting agencies should ensure that they request wage rates (including fringe benefits) for additional classifications in accordance with the principles set forth in this Memorandum. By following the guidance in this AAM, contracting agencies and contractors will benefit by receiving approvals from WHD that ensure consistency in conformed wage rates and increase efficiencies in government.

In conjunction with the guidance provided in this AAM, WHD has posted on www.dol.gov/whd/govcontracts/dbra.htm a series of frequently asked questions that include examples which will provide additional guidance regarding the reasonable relationship requirement in the conformance process. WHD also is updating its Prevailing Wage Resource Book and will provide compliance assistance on DBRA conformances at future Prevailing Wage Conferences. In addition, WHD's Branch of Construction Wage Determinations is available to assist with any questions.

"General Decision Number: NV20240042 01/05/2024

Superseded General Decision Number: NV20230042

State: Nevada

Construction Type: Residential
RESIDENTIAL CONSTRUCTION PROJECTS (consisting of single family homes and apartments up to and including 4 stories).

County: Clark County in Nevada.

Note: Contracts subject to the Davis-Bacon Act are generally required to pay at least the applicable minimum wage rate required under Executive Order 14026 or Executive Order 13658. Please note that these Executive Orders apply to covered contracts entered into by the federal government that are subject to the Davis-Bacon Act itself, but do not apply to contracts subject only to the Davis-Bacon Related Acts, including those set forth at 29 CFR 5.1(a)(1).

<p>If the contract is entered into on or after January 30, 2022, or the contract is renewed or extended (e.g., an option is exercised) on or after January 30, 2022:</p>	<ul style="list-style-type: none"> . Executive Order 14026 generally applies to the contract. . The contractor must pay all covered workers at least \$17.20 per hour (or the applicable wage rate listed on this wage determination, if it is higher) for all hours spent performing on the contract in 2024.
<p>If the contract was awarded on or between January 1, 2015 and January 29, 2022, and the contract is not renewed or extended on or after January 30, 2022:</p>	<ul style="list-style-type: none"> . Executive Order 13658 generally applies to the contract. . The contractor must pay all covered workers at least \$12.90 per hour (or the applicable wage rate listed on this wage determination, if it is higher) for all hours spent performing on that contract in 2024.

The applicable Executive Order minimum wage rate will be adjusted annually. If this contract is covered by one of the Executive Orders and a classification considered necessary for performance of work on the contract does not appear on this wage determination, the contractor must still submit a conformance request.

Additional information on contractor requirements and worker protections under the Executive Orders is available at <http://www.dol.gov/whd/govcontracts>.

Modification Number Publication Date
0 01/05/2024

ELEC0357-004 09/01/2023

<https://sam.gov/wage-determination/NV20240042/0>

	Rates	Fringes
ELECTRICIAN (Including Low Voltage Wiring).....	\$ 53.83	24.04

 ELEV0018-002 01/01/2023

	Rates	Fringes
ELEVATOR MECHANIC.....	\$ 63.95	37.335+a+b

FOOTNOTE:

a. PAID VACATION: Employer contributes 8% of regular hourly rate as vacation pay credit for employees with more than 5 years of service, and 6% for 6 months to 5 years of service.

b. PAID HOLIDAYS: New Years Day, Memorial Day, Independence Day, Labor Day, Veterans Day, Thanksgiving Day, Friday after Thanksgiving, and Christmas Day.

 ENGI0012-006 10/01/2022

	Rates	Fringes
POWER EQUIPMENT OPERATOR		
(6) Loader.....	\$ 50.77	30.85
(8) Paver (Asphalt, Aggregate, and Concrete)....	\$ 51.27	30.85

 LABO0169-002 10/01/2022

	Rates	Fringes
LABORER		
(3) Mason Tender-Cement/Concrete.....	\$ 30.30	15.02
(4) Pipelayer.....	\$ 30.55	15.02

 SUNV2014-028 09/08/2016

	Rates	Fringes
CARPENTER, Includes Drywall Hanging, Form Work, and Batt Insulation.....	\$ 16.64 **	0.00
CEMENT MASON/CONCRETE FINISHER...	\$ 17.00 **	0.00
FLOOR LAYER: SOFT FLOORS.....	\$ 28.26	12.11
GLAZIER.....	\$ 22.61	0.00
HVAC MECHANIC (HVAC Duct and Unit Installation Only).....	\$ 15.00 **	0.00
IRONWORKER, REINFORCING.....	\$ 15.21 **	0.00
IRONWORKER, STRUCTURAL.....	\$ 22.09	0.00
LABORER: Common or General.....	\$ 15.65 **	0.00
OPERATOR: Backhoe/Excavator/Trackhoe.....	\$ 20.16	0.00

OPERATOR: Bobcat/Skid Steer/Skid Loader.....	\$ 24.11	0.00
PAINTER (Brush and Roller).....	\$ 18.76	0.00
PAINTER: Spray.....	\$ 19.18	0.00
PLUMBER.....	\$ 18.94	0.00
ROOFER.....	\$ 18.50	0.00
TILE SETTER.....	\$ 29.22	0.00

WELDERS - Receive rate prescribed for craft performing operation to which welding is incidental.

=====
** Workers in this classification may be entitled to a higher minimum wage under Executive Order 14026 (\$17.20) or 13658 (\$12.90). Please see the Note at the top of the wage determination for more information. Please also note that the minimum wage requirements of Executive Order 14026 are not currently being enforced as to any contract or subcontract to which the states of Texas, Louisiana, or Mississippi, including their agencies, are a party.

Note: Executive Order (EO) 13706, Establishing Paid Sick Leave for Federal Contractors applies to all contracts subject to the Davis-Bacon Act for which the contract is awarded (and any solicitation was issued) on or after January 1, 2017. If this contract is covered by the EO, the contractor must provide employees with 1 hour of paid sick leave for every 30 hours they work, up to 56 hours of paid sick leave each year. Employees must be permitted to use paid sick leave for their own illness, injury or other health-related needs, including preventive care; to assist a family member (or person who is like family to the employee) who is ill, injured, or has other health-related needs, including preventive care; or for reasons resulting from, or to assist a family member (or person who is like family to the employee) who is a victim of, domestic violence, sexual assault, or stalking. Additional information on contractor requirements and worker protections under the EO is available at <https://www.dol.gov/agencies/whd/government-contracts>.

Unlisted classifications needed for work not included within the scope of the classifications listed may be added after award only as provided in the labor standards contract clauses (29CFR 5.5 (a) (1) (iii)).

The body of each wage determination lists the classification and wage rates that have been found to be prevailing for the cited type(s) of construction in the area covered by the wage determination. The classifications are listed in alphabetical order of ""identifiers"" that indicate whether the particular rate is a union rate (current union negotiated rate for local), a survey rate (weighted average rate) or a union average rate (weighted union average rate).

Union Rate Identifiers

A four letter classification abbreviation identifier enclosed in dotted lines beginning with characters other than ""SU"" or ""UAVG"" denotes that the union classification and rate were prevailing for that classification in the survey. Example: PLUM0198-005 07/01/2014. PLUM is an abbreviation identifier of the union which prevailed in the survey for this classification, which in this example would be Plumbers. 0198 indicates the local union number or district council number where applicable, i.e., Plumbers Local 0198. The next number, 005 in the example, is an internal number used in processing the wage determination. 07/01/2014 is the effective date of the most current negotiated rate, which in this example is July 1, 2014.

Union prevailing wage rates are updated to reflect all rate changes in the collective bargaining agreement (CBA) governing this classification and rate.

Survey Rate Identifiers

Classifications listed under the ""SU"" identifier indicate that no one rate prevailed for this classification in the survey and the published rate is derived by computing a weighted average rate based on all the rates reported in the survey for that classification. As this weighted average rate includes all rates reported in the survey, it may include both union and non-union rates. Example: SULA2012-007 5/13/2014. SU indicates the rates are survey rates based on a weighted average calculation of rates and are not majority rates. LA indicates the State of Louisiana. 2012 is the year of survey on which these classifications and rates are based. The next number, 007 in the example, is an internal number used in producing the wage determination. 5/13/2014 indicates the survey completion date for the classifications and rates under that identifier.

Survey wage rates are not updated and remain in effect until a new survey is conducted.

Union Average Rate Identifiers

Classification(s) listed under the UAVG identifier indicate that no single majority rate prevailed for those classifications; however, 100% of the data reported for the classifications was union data. EXAMPLE: UAVG-OH-0010 08/29/2014. UAVG indicates that the rate is a weighted union average rate. OH indicates the state. The next number, 0010 in the example, is an internal number used in producing the wage determination. 08/29/2014 indicates the survey completion date for the classifications and rates under that identifier.

A UAVG rate will be updated once a year, usually in January of each year, to reflect a weighted average of the current negotiated/CBA rate of the union locals from which the rate is based.

WAGE DETERMINATION APPEALS PROCESS

1.) Has there been an initial decision in the matter? This can

<https://sam.gov/wage-determination/NV20240042/0>

be:

- * an existing published wage determination
- * a survey underlying a wage determination
- * a Wage and Hour Division letter setting forth a position on a wage determination matter
- * a conformance (additional classification and rate) ruling

On survey related matters, initial contact, including requests for summaries of surveys, should be with the Wage and Hour National Office because National Office has responsibility for the Davis-Bacon survey program. If the response from this initial contact is not satisfactory, then the process described in 2.) and 3.) should be followed.

With regard to any other matter not yet ripe for the formal process described here, initial contact should be with the Branch of Construction Wage Determinations. Write to:

Branch of Construction Wage Determinations
 Wage and Hour Division
 U.S. Department of Labor
 200 Constitution Avenue, N.W.
 Washington, DC 20210

2.) If the answer to the question in 1.) is yes, then an interested party (those affected by the action) can request review and reconsideration from the Wage and Hour Administrator (See 29 CFR Part 1.8 and 29 CFR Part 7). Write to:

Wage and Hour Administrator
 U.S. Department of Labor
 200 Constitution Avenue, N.W.
 Washington, DC 20210

The request should be accompanied by a full statement of the interested party's position and by any information (wage payment data, project description, area practice material, etc.) that the requestor considers relevant to the issue.

3.) If the decision of the Administrator is not favorable, an interested party may appeal directly to the Administrative Review Board (formerly the Wage Appeals Board). Write to:

Administrative Review Board
 U.S. Department of Labor
 200 Constitution Avenue, N.W.
 Washington, DC 20210

4.) All decisions by the Administrative Review Board are final.

=====

END OF GENERAL DECISION"



SUBCONTRACTORS LIST

NAME	(MBE/WBE)	TRADE	ADDRESS	PHONE
------	-----------	-------	---------	-------

1.

2.

3.

4.

5.

6.

7.

8.

9.

10.

(Prime Contractor)

By: _____

Title: _____



SUBCONTRACTOR AFFIRMATIVE ACTION

Page 1 of 2

Instructions when submitting a Subcontractor for approval under a Federally funded project, to ensure that Affirmative Action measures were taken to comply with the Equal Opportunity Executive Order 11246.

When selecting a Subcontractor, the General Contractor is to comply with the following:

1. Bid Form - line 6
2. General Conditions of the Contract for Construction (HUD-5370) Sections 37, 38 and 39
3. Supplementary General Conditions to Construction Contract and Specifications. All Sections on "Equal Employment Opportunity"

Date: _____ Project No.: _____

(Project Name)

(Project Location)

Gentlemen:

In selecting the Subcontractor listed below, a minimum number of _____ similar subcontracting firms were contacted to submit a bid. The highlights of the Subcontractor selection will be listed below:

1. Scope of work (state kind of work, if for labor, or material, or both, and give specification reference).

2. Date Bid advertised: _____

a. Method of advertisement: _____

3. Last day Bids accepted: _____



SUBCONTRACTOR AFFIRMATIVE ACTION

Page 2 of 2

4. List of firms submitting bid (Please note the minority or women owned firms):

a. Attach the bid form(s), and a copy of the bid security deposit(s) used, for each submitted bid.

5. In your opinion, was the above procedure a "Good faith effort" in selecting a minority or women owned subcontracting firms?

Please submit this form and the requested forms along with the "Request for Acceptance of Subcontractor" for each Subcontractor you will be using.

(Prime Contractor)

By: _____

Title: _____



SUGGESTED AFFIRMATIVE ACTION PLAN FOR UTILIZATION OF PROJECT AREA BUSINESSES

Number Of All Contracts Proposed: _____

Name Of Company: _____

Dollar Value Of All Contracts Proposed: _____

Project: _____

To The Greatest Extent Feasible, Contracts Will Be Awarded Through Negotiation Or Bid To Qualified Project Area Businesses.

Goal Of These Contracts For Project Area Businesses:

PROPOSED TYPE OF CONTRACT	APPROX. COST	PROPOSED TYPE OF CONTRACT	APPROX. COST

Outline The Program To Achieve These Goals For Economically And Socially Disadvantaged:

(INSERT THIS DOCUMENT IN BID DOCUMENTS AND WITH BID) DATE: _____



SOUTHERN NEVADA REGIONAL HOUSING AUTHORITY CERTIFICATION REGARDING DRUG-FREE WORKPLACE REQUIREMENTS

Page 1 of 2

- A. The Southern Nevada Regional Housing Authority certifies that it will, or will continue to provide a drug free workplace by:
- a) Publishing a statement notifying employees that the unlawful manufacture, distribution, dispensing, possession, or use of a controlled substance is prohibited in the grantee's workplace and specifying the actions that will be taken against employees for violation of such prohibition;
 - b) Establishing an ongoing drug-free awareness program to inform employees about:
 - (1) The dangers of drug abuse in the workplace;
 - (2) The grantee's policy of maintaining a drug-free workplace;
 - (3) Any available drug counseling, rehabilitation, and employee assistance programs; and
 - (4) The penalties that may be imposed upon employees for drug abuse violations occurring in the workplace;
 - c) Making it a requirement that each employee to be engaged in the performance of the grant be given a copy of the statement required by paragraph (a);
 - d) Notifying the employee in the statement required by paragraph (a) that, as a condition of employment under the grant, the employee will:
 - (1) Abide by the terms of the statement; and
 - (2) Notify the employer in writing of his or her conviction for a violation of a criminal drug statute occurring in the workplace no later than five calendar days after such conviction;
 - e) Notifying HUD in writing, within ten calendar days after receiving notice under subparagraph (d)(2) from an employee or otherwise receiving actual notice of such conviction. Employers of convicted employees must provide notice, including position title, to every grant officer or other designee on whose grant activity the convicted employee was working, unless the Federal agency has designated a central point for the receipt of such notices. Notice shall include the identification number (s) of each affected grant;
 - f) Taking one of the following actions, within 30 calendar days of receiving notice under subparagraph (d)(2), with respect to any employee who is so convicted:
 - (1) Taking appropriate personnel action against such an employee, up to and including termination, consistent with the requirements of the Rehabilitation Act of 1973, as amended; or



**SOUTHERN NEVADA REGIONAL HOUSING AUTHORITY
CERTIFICATION REGARDING DRUG FREE WORKPLACE REQUIREMENTS**

Page 2 of 2

- (2) Requiring such employee to participate satisfactorily in a drug abuse assistance or rehabilitation program approved for such purposes by a Federal, State, or local health, law enforcement, or other appropriate agency;
 - g) Making a good faith effort to continue to maintain a drug-free workplace through implementation of paragraphs (a),(b),(c),(d),(e), and (f).
- B. The Grantee may insert in the space provided below the site(s) for the performance of work done in connection with the specific grant.

Place of performance (street, address, city, county, state, zip code)

By:

General Contractor

ATTEST



NON-COLLUSIVE AFFIDAVIT

State of (NEVADA)

County of (CLARK)

_____, being first duly sworn, deposes and says:

That he/she is _____ the party making the foregoing proposal or bid, and that such proposal or bid is genuine and not collusive or; that said bidder has not colluded, conspired, connived or agreed, directly or indirectly, with any bidder or person, to put in a sham bid or to refrain from bidding, and has not in any manner, directly or indirectly sought by agreement or collusion, or communication or conference, with any person, to fix the bid price of affiant or of any other bidder, to fix overhead, profit or cost element of said bid price, or that of any other bidder or to secure any advantage against the Housing Authority or any person interested in the proposed contract; and that all statements in said bid proposal or bid are true.

Signature of:

(Bidder, if the bidder is an Individual)

(Partner, if the bidder is a Partnership)

(Officer, if the bidder is a Corporation)

Subscribed and sworn to before me this _____ day of _____, 20_____.

My Commission Expires: _____
(Date)

Notary Public



AUTHORIZATION TO RELEASE INFORMATION

Date: _____

Attn: Linda Simpson
Contracts Administrator
Southern Nevada Regional Housing Authority (SNRHA)

RE: References

To Whom It May Concern:

We, _____, are currently participating as the Contractor or Subcontractor with _____ in responding to the noted Solicitation Invitation for Bids (IFB), Request for Proposals, (RFP), or Request for Quotes (RFQ), with the Southern Nevada Regional Housing Authority (SNRHA).

We understand the Housing Authority is assessing the contract performance records of the Bidder/Contractor and its proposed Subcontractor(s). To facilitate and enhance the performance assessment process, we are signing this Authorization to Release Information granting our permission to release and discuss our company's present and past performance information with SNRHA Procurement and Contracts Department during the Evaluation/Selection process.

By signing below I attest I am the individual who has the authority to sign for and legally bind the company. I authorize and acknowledge both the release and discussion of present and past performance information with the SNRHA as indicated above.

Company Name: _____

Signature: _____ Title: _____

Printed Name: _____

License or DUN Number: _____



SNRHA CONTRACT NO. [Click Here and Type
CLICK HERE AND TYPE TYPE OF SERVICE
\(CONSTRUCTION SERVICES\)](#)

CONTRACT BETWEEN

THE SOUTHERN NEVADA REGIONAL HOUSING AUTHORITY
AND
[CLICK HERE AND TYPE COMPANY](#)

INTRODUCTION

This [Click Here and Type](#) Contract (the "Contract") by and between the Southern Nevada Regional Housing Authority, a Nevada non-profit corporation (hereinafter "SNRHA") and [Click Here and Type COMPANY NAME](#) (hereinafter "the Contractor") is hereby entered into this _____ day of _____, 20____ (the "Effective Date").

1.0 Definitions

- 1.1 Invitation For Bids ("IFB").** A competitive solicitation process conducted by the SNRHA wherein an award is generally made to the responsive and responsible bidder that submits the lowest proposed cost.
- 1.2 Purchasing Manager ("SNRHA PM").** The SNRHA Purchasing Manager.
- 1.3 Days.** All references to "days" shall be calendar days; in the case that the last day referenced falls on a Saturday, Sunday or legal holiday, then the period of time shall be automatically extended to include the next work day.
- 1.4 Appendices.** The following documents are included in the Contract as individually noted exhibits and shall be incorporated herein and made a part of this Contract by reference as if fully set forth herein:
- 1.4.1 Appendix No. A:** form HUD-5370 EZ OR 5370 HUD General Conditions of the Contract for Construction, Public Housing Programs and any amendments thereto;
 - 1.4.2 Appendix No. B:** Section 3 Clause and Contractor Initial Response
 - 1.4.3 Appendix No. C:** form HUD-4230A, Report of Additional Classification and Rate;
 - 1.4.4 Appendix No. D:** form HUD-51000 (7/97), Schedule of Amounts for Contract Payments;
 - 1.4.5 Appendix No. E:** form HUD-51001, (3/92), Periodic Estimate of Partial Payment;
 - 1.4.6 Appendix No. F:** form HUD-51002, (3/92), Schedule of Change Orders;
 - 1.4.7 Appendix No. G:** form HUD-51003, (3/92) Schedule of Materials Stored;
 - 1.4.8 Appendix No. H:** form HUD-51004, (3/92), Summary of Materials Stored;



1.4.9 Appendix No. I: form SNRHA Subcontractor/Supplier Final Waiver of Mechanics Lien.

1.5 The following, each of which was either issued by the SNRHA as a part of the competitive solicitation and/or which was completed and returned by the Contractor in response to the solicitation (copies are not included under any of the appendices but are included herein by reference and are included within the solicitation file):

1.5.1 Current City of Las Vegas Business License;

1.5.2 Current State of Nevada Contractor's License;

1.5.3 Current Insurance Certificate/Endorsement (naming the SNRHA as "additional insured");

1.5.4 GSA Debarred and HUD Limited Denial of Participations Certifications;

1.5.5 Profile of Firm Form;

1.5.6 Subcontractors Exceeding 5% and 1% Listings;

1.5.7 Subcontractors List;

1.5.8 Subcontractor's Affirmative Action Form;

1.5.9 Certification for Business Concerns Seeking Section 3 Preference in Contracting and Demonstration of Capability;

1.5.10 Contractor's and Subcontractor's Non-Conclusive Affidavits;

1.5.11 Technical Specifications included as part of Bid Package [Click Here and Type IFB NO.;](#)

1.5.12 Summary of Work included as part of Bid Package [Click Here and Type IFB NO.;](#)

1.6 Priority. In the case of any discrepancy between this Contract and any of the above noted documents, Appendix A shall control. In the case of any discrepancy between this Contract and Appendices B-G, the requirement(s) listed within the body of this Contract shall first take precedence, then the requirement(s) listed within each appendix shall take precedence in the order they are listed above.

2.0 Term of Contract. Services pursuant to this Contract (the "Services") shall begin upon Contractor's receipt of the written Notice to Proceed by SNRHA, pursuant to Section 5 of Appendix A. Notwithstanding the continuation of any warranties contained herein, this Contract shall terminate pursuant to Sections 32 or 34 of Appendix A, or upon Final Completion (as described in Section 3.2.3.2).

3.0 Services and Payment

3.1 Scope of Services. The Contractor shall furnish all labor, material, equipment and services, and perform and complete rehabilitation services of [Click Here and Type DESCRIPTION OF PROJECT](#), located at the following location:

[Click Here and Type PROPERTY ADDRESS OR DESCRIPTION](#)

in accordance with this Agreement and IFB No. [Click Here and Type IFB NO.](#) prepared by the SNRHA and any duly executed Addenda to this Agreement. Said labor, materials, equipment and services shall be provided on the dates and times determined by the SNRHA at the above-stated



SNRHA communities and/or facilities. In addition, the SNRHA shall retain the right to implement and/or enforce any item issued as a part of IFB No. [Click Here and Type IFB NO..](#)

3.2 Cost/Value of Services

3.2.1 Labor Costs. The Contractor shall not pay wages that are less than the highest wage required by either of the following:

3.2.1.1 The wage determination rates listed in IFB No. [Click Here and Type IFB NO.](#)

3.2.1.2 Appendix A.

3.2.2 Contract Value. The SNRHA shall pay the Contractor for the performance of the Contract, in current funds, subject to additions and deductions as provided in the Technical Specifications, not-to-exceed ("NTE") the sum of:

[\\$Click Here and Type AMOUNT](#)

Contractor exceeds the above-stated NTE amount at its own risk.

3.2.3 Time for Performance. The Contractor hereby agrees to commence work under this Contract upon receipt of a written Notice to Proceed ("NTP"), submitted by SNRHA. The Contractor shall complete the project within [Click Here and Type WRITTEN NUMBER OF DAYS \(Click Here and Type NUMERICAL DIGIT\)](#) calendar days thereafter, pursuant to Section 25 of Appendix A.

3.2.3.1 Delays/Time Extensions. Time extensions for performance may be granted by the SNRHA PM and SNRHA Executive Director pursuant to Section 32 of Appendix A. Any time extension shall be granted by written modification to this Contract.

3.2.3.2 Final Completion. Pursuant to Section 20 of Appendix A, the Contractor shall notify the SNRHA PM, in writing, as to the date when in its opinion the work is substantially complete and ready for inspection. Upon receipt of such notification, SNRHA shall conduct an inspection of the work within ten (10) days. SNRHA and/or the A/E shall promptly advise the Contractor, in writing, of any remaining final punch list items following such inspection. The Contractor shall notify SNRHA in writing when all punch list items have been completed and all clean-up has been done. SNRHA will then conduct a final inspection within ten (10) days of receipt of such notification. Performance shall be considered complete upon the Contractor's receipt from SNRHA of written acceptance of the work and SNRHA's receipt from the Contractor of the following:

3.2.3.2.1 Certificate of Occupancy issued by the responsible local agency;

3.2.3.2.2 One original and two notarized copies of the Contractor's lien release (in the form attached as Appendix H), including certifications that:



SNRHA CONTRACT NO. [Click Here and Type](#)
CLICK HERE AND TYPE TYPE OF SERVICE
(CONSTRUCTION SERVICES)

- 3.2.3.2.2.1 the work was completed in accordance with the Technical Specifications, including any modifications to this Contract;
 - 3.2.3.2.2.2 the total amount due the Contractor and a separately stated amount for each unsettled claim against the SNRHA;
 - 3.2.3.2.2.3 documentation noting that the SNRHA is released of all claims, other than those stated in the Contractor's release;
 - 3.2.3.2.2.4 wages paid to laborers were paid as required herein; and
 - 3.2.3.2.2.5 all guaranties and warranties contained herein are assigned to the SNRHA.
- 3.2.4 **Liquidated Damages.** Pursuant to Section 33 of Appendix A, the Contractor agrees to pay to the SNRHA, the sum of [Click Here and Type](#) per day as fixed, agreed, liquidated damages for each consecutive calendar day beyond the time for performance as provided in Section 3.2.3, provided this Contract is not terminated pursuant to Section 11, until Final Completion is achieved.
- 3.2.5 **Non-Escalation.** Unless otherwise specified within the RFP/IFB documents, the unit prices reflected in this Contract shall remain firm with no provision for price increases during the term of the Contract.

4.0 Billing Procedure

- 4.1 To receive payment for Services rendered pursuant to this Contract, the Contractor shall:
 - 4.1.1 Comply with Section 27 of Appendix A.
 - 4.1.2 Submit a fully completed Periodic Estimate for Partial Payment form (form HUD-51001, attached as Appendix D), showing the value of the work performed each period based upon the approved breakdown of the contract price. The approved breakdown of the contract price is reflected in the Schedule of Amounts for Contract Payment (form HUD-51000, attached as Appendix C) which was previously submitted by the Contractor and approved by SNRHA. Such estimates shall be submitted not later than thirty (30) days of completing the work and shall be subject to corrections and revisions by the SNRHA.
 - 4.1.3 Submit all certified payroll reports up to the date of the work being billed and as detailed in Section 46 of Appendix A.
 - 4.1.4 Progress payments must be approved by the SNRHA PM and the SNRHA Executive Director with the concurrence of the Architect/Engineer ("A/E") prior to payment.
 - 4.1.5 Progress payment requests shall be delivered to the attention of:

Southern Nevada Regional Housing Authority
Attn: Accounts Payable
P.O. Box 1897
Las Vegas, NV 89125



- 4.1.6** The Contractor shall complete and submit the following forms as required with each request for progress payment(s):
- 4.1.6.1** Schedule for Change Orders (form HUD-51002)
 - 4.1.6.2** Schedule for Materials Stored (form HUD-51003)
 - 4.1.6.3** Summary of Materials Stored (form HUD-51004)
- 4.1.7** The SNRHA will pay each properly completed invoice received on a Net/30 basis. Any invoice received that is not properly completed will not be paid unless and/or until the Contractor complies with the applicable provisions of this contract.
- 4.1.8** Final payment will be made by SNRHA upon receipt of the Contractor's release as required by Section 3.2.3.2, all required payroll reports have been received and any wage discrepancies have been resolved by the Contractor.
- 5.0 Contractor's Obligations.** Pursuant to this Contract, the Contractor agrees to provide the specific construction obligations detailed in Appendix A and the Technical Specifications issued by the SNRHA included in IFB No. [Click Here and Type IFB NO.](#) and herein.
- 5.1** The Contractor agrees not to accept or perform any assigned work initiated by a contract amendment or change order without the prior written approval of the SNRHA PM and the SNRHA Executive Director.
- 5.1.1 Change Order Requests:** The Contractor acknowledges, by signature below, that change order requests will not be summarily approved. All change order requests must be submitted to SNRHA for approval, prior to undertaking the additional work, in accordance with Section 29 of Appendix A, and the Additional Clauses and Requirements section included in IFB No. [Click Here and Type IFB NO.](#)
 - 5.1.2 Minimum Rates of Pay.** The Contractor shall pay not less than the wages required under the wage determination rates included in IFB No. [Click Here and Type IFB NO.](#) and Section 46 of Appendix A, and any amendments thereto.
- 5.2 Supervision and Oversight.** The Contractor shall be solely responsible for providing supervision and oversight to all of the Contractor's personnel and any subcontractors that are assigned to the SNRHA work pursuant to this Contract.
- 5.3 Qualified Personnel.** The Contractor warrants and represents that it will assign only qualified personnel to perform the Services. For the purposes of this Contract, the term "qualified personnel" shall mean those personnel that are experienced and/or trained in the manner generally accepted within the Contractor's Industry.
- 5.4 Compliance with Federal and State Laws.** All work performed by the Contractor, pursuant to this Contract, shall be done in accordance with all applicable federal, state and local laws, regulations, codes and ordinances.
- 5.5 Licensing.** The Contractor shall provide SNRHA with copies of any required current City, State and/or Federal licenses. Failure to maintain these licenses in a current status during the term(s) of this Contract shall constitute a material breach thereof.
- 5.6 Permits.** Unless otherwise stated in the Contract documents, all local, state or federal permits which may be required to provide the Services ensuing from award of this Contract, whether or



not known to either the SNRHA or the Contractor at the time of the Contract execution, shall be the sole responsibility of the Contractor including any and all costs therefore.

- 5.7 Government Standards.** It is the responsibility of the Contractor to ensure that all items and Services proposed conform to all local, state and federal law concerning safety (e.g., OSHA and NIOSH) and environmental control (e.g., EPA and Clark County Pollution Regulations) and any other enacted ordinance, code, law or regulation. The Contractor shall be responsible for all costs incurred for compliance with any such possible ordinance, code, law or regulation. No time extensions shall be granted or financial consideration given to the Contractor for time or monies lost due to violations of any such ordinance, code, law or regulations that may occur.
- 5.8 Freight-On Bill and Delivery.** All costs submitted by the Contractor shall reflect the cost of delivering the proposed items and/or Services to the location(s) specified within the RFP/IFB documents or within the Contract.
- 5.9 Work on SNRHA Property.** If the Contractor's work under the Contract involves operations by the Contractor on SNRHA premises, the Contractor shall take all necessary precautions to prevent the occurrence of any injury to persons or property during the progress of such work.
- 5.10 Subcontractors.** Unless otherwise stated within the RFP/IFB/bid documents, the Contractor may not use any subcontractors to accomplish any portion of the Services required by this Contract without the prior written permission of the SNRHA PM.
- 5.11 Salaries and Expenses Relating to the Contractor's Employees.** Unless otherwise stated within the RFP/IFB documents, the Contractor shall pay all salaries and expenses of, and all federal Social Security taxes, federal and state unemployment taxes, and any similar taxes relating to its employees used in the performance of the Contract. The Contractor further agrees to comply with all federal, state and local wage and hour laws and all licensing laws applicable to its employees or other personnel furnished under this Contract.
- 5.12 Communication.** If during the period of the Contract, it is necessary that the SNRHA place toll or long distance telephone calls or facsimiles in connection with the Contractor's performance of the Contract (for complaints, adjustments, shortages, failure to deliver, etc.), it is understood that the Contractor may, at the discretion of the SNRHA, bear the charge or expense for all such calls and/or facsimiles.
- 5.13 Access to Records.** Both parties hereby agree that the Contractor will make available to the SNRHA, HUD, the Comptroller General of the United States, or any of their duly authorized representatives (including retained auditors), any books, documents, papers, and records of the Contractor which are directly pertinent to this Contract for the purpose of making audit, examination, excerpts and transcriptions.
- 5.14 Record Retention.** The Contractor shall retain all such records pertaining to this Contract for a period of not less than three (3) years after final payment or the completion of any Services provided pursuant to this Contract, whichever occurs later.
- 5.15 Backorders**
- 5.15.1** The Contractor must notify the SNRHA PM within ten (10) days of the following:
- 5.15.1.1** Any and all backordered materials;
 - 5.15.1.2** Any delay in the Contractor's performance; and



5.15.1.3 The estimated date for delivery or performance.

5.16 Inspections. Pursuant to Sections 3 and 20 of Appendix A, the Contractor shall permit SNRHA and/or the A/E to conduct periodic inspections of the work. Any deficiencies noted by SNRHA and/or the A/E during inspections shall be disclosed to the Contractor in writing within [Click Here and Type WRITTEN NUMBER OF DAYS \(Click Here and Type NUMERICAL DIGIT \)](#) days of discovery, and the Contractor shall remedy such deficiency within [Click Here and Type WRITTEN NUMBER OF DAYS \(Click Here and Type NUMERICAL DIGIT \)](#) days of notification of such from SNRHA and/or the A/E.

5.17 Progress Meetings. The Contractor shall attend progress meetings as required by SNRHA according to the schedule SNRHA will provide. Progress meetings shall be used to discuss work progress, payments, problems or deficiencies noted during inspections, overdue reports, the status of the construction schedule, and any other matters relevant to this Contract.

6.0 Insurance Requirements

6.1 The Contractor shall maintain insurance coverage during the effective term(s) of this Contract as provided in Section 36 of Appendix A and Section 4 of the Conditions of Form of Bid included in IFB No. [Click Here and Type IFB NO.](#)

6.2 The Contractor shall provide the SNRHA with current certificate(s)/endorsement(s) evidencing the insurance coverage referenced above. Failure to maintain the above-referenced insurance coverage, including naming the SNRHA as an additional insured (where appropriate) during the term(s) of this Contract shall constitute a material breach thereof.

6.3 Insurance certificate(s)/endorsement(s) shall be delivered to:

**Purchasing Manager
Contracts & Purchasing
Southern Nevada Regional Housing Authority
Post Office Box 1897
Las Vegas, NV 89125**

7.0 Indemnification

7.1 The Contractor shall protect, indemnify and hold the SNRHA, its officers, employees, and agents harmless from and defend against any and all claims, damages, losses, suits, actions, decrees, judgments, attorney's fees, court costs and other expenses of any kind or character which the SNRHA, its officers, employees, agents, consulting engineers or other retained consultants may suffer, or which may be sought against, recovered from or obtainable against the SNRHA, its officers, employees, and agents, based upon the Contractor's actions or failure to act during the performance of the Contractor's duties hereunder, or as a result of any work performed by the Contractor, regardless of when such claims shall arise. The Contractor's duty to indemnify SNRHA shall apply regardless of whether or not the event which gave rise to such a claim was caused, in part, by SNRHA.

7.2 Any money due by the Contractor under and by virtue of this Contract which is considered necessary by the SNRHA for such purpose, may be retained by the SNRHA for its protection; or in case no money is due, its surety may be held until all such claims, damages, losses, suits, actions, decrees, judgments, attorney's fees and court costs and other expenses of any kind or character as aforesaid shall have been settled and suitable evidence to that effect furnished to the SNRHA provided, however, that money due the Contractor will not be withheld when the Contractor produces satisfactory evidence that it is adequately protected by applicable public liability and property damage insurance;



- 7.3** The Contractor shall, at its own expense, defend the SNRHA, its officers, employees, and agents, against any and all claims, suits or actions which may be brought against them, or any of them, as a result of, or by reason of, or arising out of, or on account of, or in consequence of any act or failure to act the consequences of which the Contractor has indemnified the SNRHA, its officers, employees, and agents against. If the Contractor fails to do so, the SNRHA shall have the right, but not the obligation, to defend the same and to charge all direct and incidental costs of such defense to the Contractor including attorney's fees and court costs.
- 7.4** The Contractor guarantees the payment of all claims for materials, supplies and labor, and all other claims against it or any subcontractor, in connection with the Contract.
- 7.5** The Contractor shall provide that any authorized contractual arrangement with a subcontractor shall be in conformance with the terms of this Contract including the indemnity provisions of this Section 8.

8.0 Financial Viability and Regulatory Compliance

- 8.1** The Contractor warrants and represents that its corporate entity is in good standing with all applicable federal, state and local licensing authorities and that it possesses all requisite licenses to perform the Services required by this Contract. The Contractor further warrants and represents that it owes no outstanding federal, state or local taxes or business assessments.
- 8.2** Contractor agrees to promptly disclose to the SNRHA any IRS liens or insurance or licensure suspension or revocation that may adversely affect its capacity to perform the Services required by this Contract. The failure by the Contractor to disclose such issue to the SNRHA in writing within five (5) days of Contractor's receipt of such notification will constitute a material breach of this Contract.
- 8.3** The Contractor further agrees to promptly disclose to the SNRHA any change of its ownership and/or any declaration of bankruptcy that the Contractor may undergo during the term(s) of this Contract. The failure of the Contractor to disclose any change of its ownership and/or its declaration of bankruptcy within five (5) days of said actions shall constitute a material breach of this Contract.

9.0 Disputes

- 9.1** All disputes arising under or relating to this Contract, except for disputes relating to Labor Standards - Davis Bacon and Related Acts, shall be disposed of in accordance with Section 31 of Appendix A.

10.0 Breach. Pursuant to 24 CFR 85.36(i), as issued by the Office of the Secretary, HUD, the SNRHA and the Contractor each agree to comply with the following provisions:

- 10.1 Termination For Cause and Convenience.** SNRHA may terminate this Contract for cause, pursuant to Section 32 of Appendix A. SNRHA may also terminate this Contract for convenience pursuant to Section 34 of Appendix A. Any termination notice shall state the following:
- 10.1.1** whether the Contract is being terminated for convenience or cause;
 - 10.1.2** whether the Contract is terminated in whole or in part;
 - 10.1.3** if terminated for cause, the acts or omissions constituting the material breach, the SNRHA PM's determination that failure to perform is not excusable, SNRHA's right to



charge excess costs of re-procurement to the Contractor, and the Contractor's appeal rights;

10.1.4 effective date of termination;

10.1.5 if applicable, the Contractor's right to proceed under the non-terminated portion of the Contract; and

10.1.6 any special instructions.

10.2 Prior to termination, the SNRHA may choose, at its sole discretion, to warn the Contractor, verbally or in writing, of any issue of non-compliance or unsatisfactory performance. Such warning may include placing the Contractor on probation, thereby giving the Contractor a certain period of time to correct the deficiencies or potentially suffer termination. The SNRHA shall maintain in the Contract file a written record of any such warning detailing all pertinent information. If the Contractor does not agree with such action, the Contractor shall have ten (10) days from receipt of such verbal or written warning to dispute or protest such action in writing; if it does not do so within the 10-day period, it shall have no recourse but to accept the SNRHA's position on the issue. The written protest must detail all pertinent information pertaining to the dispute, including any justification detailing the SNRHA's alleged incorrect action(s).

10.3 After termination, if the Contractor does not agree with the SNRHA's justification for the termination, the Contractor shall have ten (10) days from the date of termination to dispute such action in writing.

10.4 Any protest or dispute submitted by the Contractor under this Section shall thereafter be conducted in accordance with Section 9.1 herein.

10.5 All rights and remedies granted to SNRHA herein and any other rights and remedies which SNRHA may have at law and in equity are hereby declared to be cumulative and not exclusive. The fact that SNRHA may have exercised any remedy without terminating this Contract shall not impair SNRHA's rights thereafter to terminate or to exercise any other remedy herein granted, or to which SNRHA may be otherwise entitled.

11.0 Applicable Federal Law. Pursuant to 24 CFR 85.36(i), as issued by the Office of the Secretary, HUD, the SNRHA and the Contractor each agree to comply with the following provisions:

11.1 Executive Order 11246. For all construction contracts awarded in excess of \$10,000, both parties hereby agree to comply with "Executive Order 11246 of September 24, 1965, entitled "Equal Employment Opportunity," as amended by Executive Order 11375 of October 13, 1967, and as supplemented in Department of Labor Regulations (41 CFR Chapter 60).

11.2 Copeland "Anti-Kickback" Act. For all construction or repair contracts awarded, both parties hereby agree to comply with the Copeland "Anti-Kickback" Act (18 U.S.C. 874) as supplemented in Department of Labor Regulations (29 CFR Part 3).

11.3 Mandatory Section 3 Requirements: The SNRHA has adopted a scale (See Appendix B) for hiring that is used on all construction, service and professional contracts that contain a labor component as referenced HUD Act of 1968, as amended, 12 U. S. C. 1701u. All Section 3 covered contracts shall include the following clause (referred as to the Section 3 Clause):

11.3.1 The work to be performed under this contract is subject to the requirements of Section 3 of the Housing and Urban Development Act of 1968, as amended, 12 U.S.C. 1701u (Section 3). The purpose of Section 3 is to ensure that employment and other economic opportunities generated by HUD assistance or HUD-assisted projects covered by



Section 3, shall, to the greatest extent feasible, be directed to low- and very low-income persons, particularly persons who are recipients of HUD assistance for housing.

- 11.3.2 The parties to this contract agree to comply with HUD's regulations in 24 CFR part 135, which implement Section 3. As evidenced by their execution of this contract, the parties to this contract certify that they are under no contractual or other impediment that would prevent them from complying with the part 135 regulations.
- 11.3.3 The contractor agrees to send to each labor organization or representative or workers with which the contractor has a collective bargaining agreement or other understanding, if any, a notice advising the labor organization or workers' representative of the contractor's commitments under this Section 3 clause, and will post copies of the notice in conspicuous places at the work site where both employees and applicants for training and employment positions can see the notice. The notice shall describe the Section 3 preference, shall set forth minimum number and job titles subject to hire, availability of apprenticeship and training positions, the qualifications for each; and the name and location of the person(s) taking applications for each of the positions; and the anticipated date the work shall begin.
- 11.3.4 The contractor agrees to include this Section 3 clause in every subcontract subject to compliance with regulations in 24 CFR part 135, and agrees to take appropriate action, as provided in an applicable provision of the subcontract or in this Section 3 clause, upon a finding that the subcontractor is in violation of the regulations in 24 CFR part 135. The contractor will not subcontract with any subcontractor where the contractor has notice or knowledge that the subcontractor has been found in violation of the regulations in 24 CFR part 135.
- 11.3.5 The contractor will certify that any vacant employment positions, including training positions, that are filled (1) after the contractor is selected but before the contract is executed, and (2) with persons other than those to whom the regulations of 24 CFR part 135 require employment opportunities to be directed, were not filled to circumvent the contractor's obligations under 24 CFR part 135.
- 11.3.6 Noncompliance with HUD's regulations in 24 CFR part 135 may result in sanctions, termination of this contract for default, and debarment or suspension from future HUD assisted contracts.
- 11.3.7 With respect to work performed in connection with Section 3 covered Indian housing assistance, Section 7(b) of the Indian Self-Determination and Education Assistance Act (25 U.S.C. 450e) also applies to the work to be performed under this contract. Section 7(b) requires that to the greatest extent feasible (i) preference and opportunities for training and employment shall be given to Indians, and (ii) preference in the award of contracts and subcontracts shall be given to Indian organizations and Indian-owned Economic Enterprises. Parties to this contract that are subject to the provisions of Section 3 to the maximum extent feasible, but not in derogation of compliance with Section 7(b).
- 11.4 **Davis-Bacon Act.** For all construction contracts awarded in excess of \$2,000 when required by Federal Grant Program legislation, both parties hereby agree to comply with the Davis-Bacon Act (40 U.S.C. 276a to 276a-7) as supplemented in Department of Labor Regulations (29 CFR Part 5).



- 11.5 Sections 103 and 107 of the Contract Work Hours and Safety Standards Act.** For all construction contracts awarded in excess of \$2,000 and for other contracts, which involve the employment of mechanics or laborers awarded in excess of \$2,500, both parties hereby agree to comply with the Sections 103 and 107 of the Contract Work Hours and Safety Act (40 U.S.C. 327-330) as supplemented in Department of Labor Regulations (29 CFR Part 5).
- 11.6 Clean Air Act.** For all contracts in excess of \$100,000, both parties hereby agree to comply with all applicable standards, orders or requirements issued under Section 306 of the Clean Air Act (42 U.S.C. 1857(h), Section 508 of the Clean Water Act (33 U.S.C. 1368), Executive Order 11738, and Environmental Protection Agency regulations (40 CFR Part 15).
- 11.7 Energy Policy and Conservation Act.** Both parties hereby agree to comply with all mandatory standards and policies relating to energy efficiency, which are contained in the state energy conservation plan issued in compliance with the Energy Policy and Conservation Act (Pub. L. 94-163, 89 Stat. 871).
- 11.8 Additional Federally Required Orders/Directives.** Both parties agree that they will comply with the following laws and directives, where applicable:
- 11.8.1** Executive Order 11061, as amended, which directs the Secretary of HUD to take all action which is necessary and appropriate to prevent discrimination by agencies that utilize federal funds.
- 11.8.2** Public Law 88-352, Title VI of the Civil Rights Act of 1964, which provides that no person in the United States shall, on the basis of race, color, national origin or sex, be excluded from participation in, denied the benefits of, or subjected to discrimination under any program or activity which receives federal financial assistance. The SNRHA hereby extends this requirement to the Contractor and its private contractors. Specific prohibited discriminatory actions and corrective action are described in Chapter 2, Subtitle C, Title V of the Anti-Drug Abuse Act of 1988 (42 U.S.C. 1901 et. seq.).
- 11.8.3** Public Law 90-284, Title VIII of the Civil Rights Act of 1968, popularly known as the Fair Housing Act, which provides for fair housing throughout the United States and prohibits any person from discriminating in the sale or rental of housing, the financing of housing or the provision of brokerage services, including in any way making unavailable or denying a dwelling to any person because of race, color, religion, sex or national origin. Pursuant to this statute, the SNRHA requires that the Contractor administer all programs and activities, which are related to housing and community development in such a manner as to affirmatively further fair housing.
- 11.8.4** The Age Discrimination Act of 1975, which prohibits discrimination on the basis of age.
- 11.8.5** Anti-Drug Abuse Act of 1988 (42 U.S.C. 11901 et. seq.).
- 11.8.6** HUD Information Bulletin 909-23 which is the following:
- 11.8.6.1** Notice of Assistance Regarding Patent and Copyright Infringement;
- 11.8.6.2** Clean Air and Water Certification; and
- 11.8.6.3** Energy Policy and Conservation Act.
- 11.8.7** That the funds that are provided by the SNRHA and HUD hereunder shall not be used, directly or indirectly, to employ, award a Contract to, or otherwise engage the services of any debarred, suspended or ineligible Contractor.



- 11.8.8** That none of the personnel who are employed in the administration of the work required by this Contract shall, in any way or to any extent, be engaged in the conduct of political activities in violation of Title V, Chapter IS, of the United States Code.
- 11.8.9** That neither party has colluded, conspired, connived or agreed, directly or indirectly, with any bidder or person, to put in a sham bid or to refrain from bidding, and has not in any manner, directly or indirectly, sought by agreement or collusion, or communication or conference, with any person, to fix the bid price of affiant or of any other bidder, to fix overhead, profit or cost element of said bid price, or that of any other bidder, or to secure any advantage against either party or any person interested in the proposed Contract; and that all statements in said proposal or bid are true.
- 11.8.10** The mention herein of any statute or Executive Order is not intended as an indication that such statute or Executive Order is necessarily applicable nor is the failure to mention any statute or Executive Order intended as an indication that such statute or Executive Order is not applicable. In this connection, therefore, each provision of law and each clause, which is required by law to be inserted in this Contract, shall be deemed to have been inserted herein, and this Contract shall be read and enforced as though such provision or clause had been physically inserted herein. If, through mistake or otherwise, any such provision is not inserted or is inserted incorrectly, this Contract shall forthwith be physically amended to make such insertion or correction upon the application of either part.
- 11.9 Rights in Data and Patent Rights (Ownership and Proprietary Interest).** SNRHA shall have exclusive ownership of, all proprietary interest in, and the right to full and exclusive possession of all information, materials, and documents discovered or produced by Contractor pursuant to the terms of this Contract, including but not limited to reports, memoranda or letters concerning the research and reporting tasks of this Contract.
- 12.0 Debarment and Suspension.** Contractor agrees, by submitting this bid, to include this clause without modification in all lower tier transactions, solicitations, bids, contracts and subcontracts.
- 12.1** By execution of this Contract with the SNRHA, the Contractor hereby certifies that neither it nor its principals are presently debarred, suspended, proposed for debarment, declared ineligible, or voluntarily excluded from participation in this transaction by any federal department or agency. This certification is made pursuant to the regulations implementing Executive Order 12549, Debarment and Suspension, 28 C.F.R. pt. 67 § 67.510, as published as pt. VII of the May 26, 1988, Federal Register (pp. 19610-19211), and any relevant program-specific regulations.
- 12.2** Contractor acknowledges and agrees that, pursuant to Federal Acquisition Regulation ("FAR") 9.406-2, the SNRHA has discretion to suspend and/or debar contractor from conducting future business with the SNRHA for contractor's commission of the offenses outlined in FAR 9.406-2, including, but not limited to, violation of any applicable Federal law, commission of fraud, embezzlement and/or theft, receipt of stolen property, use of inappropriate construction materials, repeated contract violations and recurrent re-inspections. The SNRHA's right to suspend and/or debar contractor is in addition to the SNRHA's right to assess the monetary penalties outlined in Section 12.2.1.
- 12.2.1** Contractor acknowledges and agrees that the SNRHA may assess a monetary penalty for a third, and any subsequent, inspection caused by Contractor's negligence or willful disregard in failing to complete Contractor's scope of work by the initial, or secondary, inspection date assigned by the SNRHA or any other local or state governing body. The penalty for a third, and any subsequent, inspection shall be a \$200 re-inspection appointment fee plus a \$75 per hour services fee plus any overtime fees, if applicable.



The monetary penalty shall be paid by Contractor to the SNRHA, or deducted by the SNRHA from the contractor's owed balance under the contract.

13.0 Lobbying Certification. By execution of this Contract with the SNRHA the Contractor thereby certifies, to the best of his or her knowledge and belief, that:

- 13.1** No federal appropriated funds have been paid or will be paid, by or on behalf of the undersigned, to any person for influencing or attempting to influence an officer or employee of an agency, a Member of Congress, an officer or employee of Congress, or an employee of a Member of Congress in connection with the awarding of any federal contract, the making of any federal loan, the entering into of any cooperative agreement, or modification of any federal contract, grant, loan, or cooperative agreement.
- 13.2** If any funds other than federal appropriated funds have been paid or will be paid to any person for influencing or attempting to influence an officer or employee of an agency, a Member of Congress, an officer or employee of Congress, or an employee of a Member of Congress in connection with this federal contract, grant, loan, or cooperative agreement, the Contractor shall complete and submit Standard Form – LLL, Disclosure Form to Report Lobbying, in an accordance with its instructions.
- 13.3** The Contractor shall require that the language of this certification be included in the award documents for all subawards at all tiers (including subcontracts, subgrants, and contracts under grants, loans, and cooperative agreements) and that all subrecipients shall certify and disclose accordingly.

14.0 Miscellaneous Provisions

- 14.1 Notices, Invoices and Reports.** Except as otherwise provided in this Contract, all notices, reports, records or other communications that are required or permitted to be given to the parties under this Contract shall be sufficient in all respects if given in writing and delivered in person, by facsimile, by overnight courier or by registered or certified mail, postage prepaid, return receipt requested, to the receiving party at the following address:

If to SNRHA:

 Southern Nevada Regional Housing Authority
 340 North 11th Street, Suite 100
 Las Vegas, NV 89101
 Phone and Email _____

If to Contractor:

Title
Company
Address
Phone and Email

or such other address as such party may have given to the other parties by notice pursuant to this Section. Notice shall be deemed given on (i) the date such notice is personally delivered, (ii) three (3) days after the mailing if sent by certified or registered mail, (iii) one (1) business day after the date of delivery to the overnight courier if sent by overnight courier, or (iv) the next succeeding business day after transmission by facsimile, provided that any fax delivery is followed up with another method of notice listed in this Section within one (1) business day of sending the facsimile.



- 14.2 Taxes.** All persons doing business with the SNRHA are hereby made aware that the SNRHA is exempt from paying Nevada State Sales and Use Taxes and Federal Excise Taxes. A letter of Tax Exemption will be provided upon request.
- 14.3 Officials, Agents and Employees of the SNRHA Not Personally Liable.** It is agreed by and between the parties hereto that in no event shall any official, officer, employee, or agent of the SNRHA in any way be personally liable or responsible for any covenant or agreement herein contained whether expressed or implied, nor for any statement, representation or warranty made herein or in any connection with this Contract.
- 14.4 Assignment.** Except pursuant to Section 35 of Appendix A, the Contractor shall not assign or transfer any interest in this Contract.
- 14.5 Entire Agreement; Amendment.** This Contract (including all Appendices attached hereto or other documents included by reference herein) constitutes the entire contract between the parties hereto and may not be modified except by an instrument in writing signed by the party to be charged. This Contract may be amended, supplemented or modified only by a written instrument duly executed by or on behalf of each party hereto.
- 14.6 Governing Law; Venue.** The laws of the State of Nevada shall govern the validity, construction and effect of this Contract, unless such laws are superseded by, or in conflict with applicable federal laws and/or federal regulations. Each party irrevocably submits to the exclusive jurisdiction of any federal or state court located in Clark County, Nevada in any action, suit or proceeding arising out of or relating to this Contract, and agrees that any such action, suit or proceeding shall be brought only in such court.
- 14.7 Attorney's Fees.** In the event that litigation is commenced by one party hereto against the other in connection with the enforcement of any provision of this Contract, the prevailing party shall be paid by the losing party all court costs and other expenses of such litigation, including reasonable attorneys' fees. The amount so allowed as attorneys' fees shall be taxed to the losing party as costs of the suit, unless prohibited by law.
- 14.8 Severability.** If any provision of this Contract or any portion or provision hereof applicable to any particular situation or circumstance is held invalid, the remainder of this Contract or the remainder of such provision (as the case may be), and the application thereof to other situations or circumstances shall not be affected thereby.
- 14.9 Waiver of Breach.** A waiver of either party of any terms or conditions of this Contract in any instance shall not be deemed or construed as a waiver of such term or condition for the future, or of any subsequent breach thereof. All remedies, rights, undertakings, obligations, and agreements contained in this Contract shall be cumulative and none of them shall limit any other remedy, right, obligation or agreement of either party.
- 14.10 Time of the Essence.** Time is of the essence for performance of this Contract.
- 14.11 Payment and Performance Bonds.** If the Contract Value as provided in Section 3.2.2 exceeds \$100,000, the Contractor shall furnish bonds covering faithful performance of the Contract and payment obligations arising thereunder. Bonds may be obtained through the Contractor's usual source and the cost thereof shall be included in the Contract Value. The amount of each bond shall be equal to one hundred percent (100%) of the Contract Value. In addition:
- 14.11.1** The bond must be approved and reviewed by the SNRHA PM;
- 14.11.2** The bond must name the Southern Nevada Regional Housing Authority as obligee;



SNRHA CONTRACT NO. [Click Here and Type](#)
[CLICK HERE AND TYPE TYPE OF SERVICE](#)
(CONSTRUCTION SERVICES)

14.11.3 The Contractor shall deliver the required bonds to SNRHA before the commencement of any work pursuant to this Contract.

14.12 Limitation of Liability. In no event shall the SNRHA be liable to the Contractor for any indirect, incidental, consequential or exemplary damages.

15.0 Certifications. The undersigned representatives of each party acknowledge by signature below that they have reviewed the foregoing and understand their respective obligations as defined herein. This Contract may be signed in counterparts.

[CLICK HERE AND TYPE COMPANY NAME](#)

By: _____ Date: _____
[CLICK HERE AND TYPE NAME](#)
[CLICK HERE AND TYPE TITLE](#)

SOUTHERN NEVADA REGIONAL HOUSING AUTHORITY

By: _____ Date: _____
CHAD WILLIAMS
EXECUTIVE DIRECTOR

Sample



ATTACHMENT D

SNRHA'S SECTION 3 CLAUSE AND CONTRACTOR INITIAL RESPONSE FORM

(Complete and return under Tab 7 of your Bid Submittal)

**SOUTHERN NEVADA REGIONAL HOUSING AUTHORITY
24 CFR PART 75 - SNRHA SECTION 3 CLAUSE**

This contract is subject to the following conditions under Section 2 of the Housing and Urban Development Act of 1968, as amended, 12 U.S.C. 1701u (Section 3)

- A. The work to be performed under this contract is subject to the requirements of Section 3 of the Housing and Urban Development Act of 1968, as amended, 12 U.S.C. 1701u (Section 3). The purpose of Section 3 is to ensure that employment and other economic opportunities generated by HUD assistance or HUD-assisted projects covered by Section 3, shall, to the greatest extent feasible, be directed to low- and very low-income persons, particularly persons who are recipients of HUD assistance for housing.
- B. The parties to this contract agree to comply with HUD's regulations in 24 CFR Part 75, which implement Section 3. As evidenced by their execution of this contract, the parties to this contract certify that they are under no contractual or other impediment that would prevent them from complying with the part 135 regulations.
- C. The contractor agrees to send to each labor organization or representative or workers with which the contractor has a collective bargaining agreement or other understanding, if any, a notice advising the labor organization or workers' representative of the contractor's commitments under this Section 3 clause, and will post copies of the notice in conspicuous places at the work site where both employees and applicants for training and employment positions can see the notice. The notice shall describe the Section 3 preference, shall set forth minimum number and job titles subject to hire, availability of apprenticeship and training positions, the qualifications for each; and the name and location of the person(s) taking applications for each of the positions; and the anticipated date the work shall begin.
- D. The contractor agrees to include this Section 3 clause in every subcontract subject to compliance with regulations in 24 CFR Part 75, and agrees to take appropriate action, as provided in an applicable provision of the subcontract or in this Section 3 clause, upon a finding that the subcontractor is in violation of the regulations in 24 CFR Part 75. The contractor will not subcontract with any subcontractor where the contractor has notice or knowledge that the subcontractor has been found in violation of the regulations in 24 CFR Part 75.
- E. The contractor will certify that any vacant employment positions, including training positions, that are filled (1) after the contractor is selected but before the contract is executed, and (2) with persons other than those to whom the regulations of 24 CFR Part 75 require employment opportunities to be directed, were not filled to circumvent the contractor's obligations under 24 CFR Part 75.
- F. Noncompliance with HUD's regulations in 24 CFR Part 75 may result in sanctions, termination of this contract for default, and debarment or suspension from future HUD assisted contracts.
- G. With respect to work performed in connection with Section 3 covered Indian housing assistance, Section 7(b) of the Indian Self-Determination and Education Assistance Act (25 U.S.C. 450e) also applies to the work to be performed under this contract. Section 7(b) requires that to the greatest extent feasible (i) preference and opportunities for training and employment shall be given to Indians, and (ii) preference in the award of contracts and subcontracts shall be given to Indian organizations and Indian-owned Economic Enterprises. Parties to this contract that are subject to the provisions of Section 3 to the maximum extent feasible, but not in derogation of compliance with Section 7(b).

ACKNOWLEDGE ACCEPTANCE & RECEIPT:

PRINT NAME

DATE

SIGNATURE

SECTION 3 – CONTRACTOR INITIAL RESPONSE

Company Name (Contractor)

Contact Person

Address

City

State

Zip Code

Phone

Fax

E-mail

SECTION 3 COMMITMENT

To meet the requirements of Section 3 of the Housing Act of 1968 [12 U.S.C. 1701u], as amended, the terms of the contract, and pursuant to Southern Nevada Regional Housing Authority's (SNRHA's) policies outlined in the Section 3 Policy dated July 13, 2016, please answer the following questions;

- Do you expect to create any new full time employment opportunities during the period while under contract with SNRHA? _____
- If **yes**, of the full time employment opportunities that are created, how many will result in the direct hiring of Section 3 eligible SNRHA's Public Housing residents, Housing Choice Voucher participants and/or low income persons within Clark County (determined by HUD's criteria for low income)? _____
- If **no**, what is your plan to create other employment and training opportunities in order to comply with Section 3 requirements?

Upon award of the contract, the contractor will meet with SNRHA to develop the Section 3 Plan specific to the contract, including scheduled progress and compliance deadlines.

Signature

Date



24 CFR PART 135 - SNRHA SECTION 3 CLAUSE
(SNRHA BOARD APPROVED JUNE 15, 2017)

This contract is subject to the following conditions under Section 2 of the Housing and Urban Development Act of 1968, as amended, 12 U.S.C. 1701u (Section 3)

- A. The work to be performed under this contract is subject to the requirements of Section 3 of the Housing and Urban Development Act of 1968, as amended, 12 U.S.C. 1701u (Section 3). The purpose of Section 3 is to ensure that employment and other economic opportunities generated by HUD assistance or HUD-assisted projects covered by Section 3, shall, to the greatest extent feasible, be directed to low- and very low-income persons, particularly persons who are recipients of HUD assistance for housing.
- B. The parties to this contract agree to comply with HUD's regulations in 24 CFR Part 135, which implement Section 3. As evidenced by their execution of this contract, the parties to this contract certify that they are under no contractual or other impediment that would prevent them from complying with the part 135 regulations.
- C. The contractor agrees to send to each labor organization or representative or workers with which the contractor has a collective bargaining agreement or other understanding, if any, a notice advising the labor organization or workers' representative of the contractor's commitments under this Section 3 clause, and will post copies of the notice in conspicuous places at the work site where both employees and applicants for training and employment positions can see the notice. The notice shall describe the Section 3 preference, shall set forth minimum number and job titles subject to hire, availability of apprenticeship and training positions, the qualifications for each; and the name and location of the person(s) taking applications for each of the positions; and the anticipated date the work shall begin.
- D. The contractor agrees to include this Section 3 clause in every subcontract subject to compliance with regulations in 24 CFR Part 135, and agrees to take appropriate action, as provided in an applicable provision of the subcontract or in this Section 3 clause, upon a finding that the subcontractor is in violation of the regulations in 24 CFR Part 135. The contractor will not subcontract with any subcontractor where the contractor has notice or knowledge that the subcontractor has been found in violation of the regulations in 24 CFR Part 135.
- E. The contractor will certify that any vacant employment positions, including training positions, that are filled (1) after the contractor is selected but before the contract is executed, and (2) with persons other than those to whom the regulations of 24 CFR part 135 require employment opportunities to be directed, were not filled to circumvent the contractor's obligations under 24 CFR Part 135.
- F. Noncompliance with HUD's regulations in 24 CFR Part 135 may result in sanctions, termination of this contract for default, and debarment or suspension from future HUD assisted contracts.
- G. With respect to work performed in connection with Section 3 covered Indian housing assistance, Section 7(b) of the Indian Self-Determination and Education Assistance Act (25 U.S.C. 450e) also applies to the work to be performed under this contract. Section 7(b) requires that to the greatest extent feasible (i) preference and opportunities for training and employment shall be given to Indians, and (ii) preference in the award of contracts and subcontracts shall be given to Indian organizations and Indian-owned Economic Enterprises. Parties to this contract that are subject to the provisions of Section 3 to the maximum extent feasible, but not in derogation of compliance with Section 7(b).

ACKNOWLEDGE, ACCEPTANCE AND RECEIPT:

PRINT NAME

DATE

SIGNATURE



SECTION 3 – CONTRACTOR INITIAL RESPONSE
(SNRHA BOARD APPROVED JUNE 15, 2017)

Company Name (Contractor)

Contact Person

Address

City

State

Zip Code

Phone

Fax

E-mail

SECTION 3 COMMITMENT

To meet the requirements of Section 3 of the Housing Act of 1968 [12 U.S.C. 1701u], as amended, the terms of the contract, and pursuant to Southern Nevada Regional Housing Authority's (SNRHA's) policies outlined in the Section 3 Policy dated July 13, 2016, please answer the following questions;

- Do you expect to create any new full time employment opportunities during the period while under contract with SNRHA? _____
- If **yes**, of the full time employment opportunities that are created, how many will result in the direct hiring of Section 3 eligible SNRHA's Public Housing residents, Housing Choice Voucher participants and/or low income persons within Clark County (determined by HUD's criteria for low income)? _____
- If **no**, what is your plan to create other employment and training opportunities in order to comply with Section 3 requirements?

Upon award of the contract, the contractor will meet with SNRHA to develop the Section 3 Plan specific to the contract, including scheduled progress and compliance deadlines.

Signature

Date



ATTACHMENT E

EQUAL EMPLOYMENT OPPORTUNITY (EEO) POLICY

(Place your EEO Policy Under Tab 8 of your Bid)



ATTACHMENT F

SECTION 3 BUSINESS PREFERENCE (OPTIONAL)



**CERTIFICATION FOR BUSINESS CONCERNS SEEKING SECTION 3 PREFERENCE
IN CONTRACTING AND DEMONSTRATION OF CAPABILITY**

(SNRHA BOARD APPROVED JUNE 15, 2017)

NAME OF BUSINESS: _____

ADDRESS OF BUSINESS: _____

TYPE OF BUSINESS: Corporation Partnership Sole Proprietorship Joint Venture

Attached is the following documentation as evidence of status:

FOR BUSINESS CLAIMING STATUS AS A SECTION 3 RESIDENT-OWNED ENTERPRISE

Copy of resident lease Other evidence Copy of evidence of participation in a public assistance program

For the business entity as applicable:

- Copy of Articles of Incorporation
- Assumed Business Name Certificate
- List of owners/stockholder and % of each
- Latest Board minutes appointing officers
- Organization chart with names and titles and brief functional statement
- Certificate of Good Standing
- Partnership Agreement
- Corporation Annual Report
- Additional documentation

**FOR BUSINESS CLAIMING SECTION 3 STATUS BY SUBCONTRACTING 25% OF THE DOLLAR AWARDED
TO QUALIFIED SECTION 3 BUSINESS**

- List of subcontracted Section 3 business and subcontract amount
- Copy of certification from City of Las Vegas or Clark County

**FOR BUSINESS CLAIMING SECTION 3 STATUS, CLAIMING AT LEAST 30% OF THEIR WORKFORCE ARE
CURRENTLY SECTION 3 RESIDENTS OR WERE SECTION 3 ELIGIBLE RESIDENTS WITHIN 3 YEARS OF
DATE OF FIRST EMPLOYMENT WITH THE BUSINESS**

- List of all current full time employees
- PHA Residential lease (less than 3 years from date of employment)
- List of all employees claiming Section 3 status
- Other evidence of Section 3 status (less than 3 years from date of employment)

**EVIDENCE OF ABILITY TO PERFORM SUCCESSFULLY UNDER THE TERMS AND CONDITIONS OF THE
PROPOSED CONTRACT**

- Current financial statement
- Statement of ability to comply
- List of owned equipment
- List of all contracts for the past 2 years with public policy

Corporate Seal

Authorizing Name and Signature

Notary

Title

My term expires: _____



SOUTHERN NEVADA REGIONAL HOUSING AUTHORITY

PREFERENCE FOR SECTION 3 BUSINESS CONCERNS IN CONTRACTING OPPORTUNITIES

The Southern Nevada Regional Housing Authority has established the following priority for preference when providing contracting opportunities to Section 3 Businesses:

Priority 1

Category 1 Business

Business concerns that are 51 percent or more owned by residents of the housing development or developments for which the Section 3-covered assistance is expended, or whose full-time, permanent workforce includes 30% of these persons as employees.

Priority 2

Category 2 Business

Business concerns that are 51% or more owned by residents of the housing developments or developments managed by the HA that is expending the Section 3 covered assistance, or whose full-time, permanent workforce includes 30% of these persons as employees.

Priority 3

Category 3 Business

Business concerns that are 51% or more owned by Section 3 residents in the metropolitan area, or whose permanent, full-time workforce includes no less than 30% Section 3 residents in the metropolitan area or that subcontracts in excess of 25% of the total amount of subcontracts to business concerns identified in Priority 1 and/or Priority 2 of this section.

For Bidding Preference in Awarding Contracts, please see the following Federal Register, Page 33890/Federal Register/Vol. 59. No. 125/Thursday, June 30, 1994/Rules and Regulations

(SNRHA Board Approved June 15, 2017)



Federal Register



EXAMPLES OF SNRHA EFFORTS TO AWARD CONTRACTS TO SECTION 3 BUSINESS CONCERNS

In accordance with 24 C.F.R § 135, SNRHA will utilize the following methods to ensure that effort is made to award contracts to Section 3 business concerns.

1. Utilize procurement procedures that provide contracting preference for Section 3 business concerns for each applicable procurement method authorized in 24 C.F.R. § 85.36(d).
2. Advertise contracting opportunities via newspaper, mailings, posting notices that provide general information about the work to be contracted and where to obtain additional information.
3. In determining the responsibility of potential contractors, SNRHA considers the bidder's record of Section 3 compliance as evidenced by past actions and their current plans for the pending contract.
4. Coordinate pre-bid meetings at which the Section 3 business concerns would be informed in detail of contract requirements and contracting opportunities.
5. Conduct workshops on SNRHA's contracting procedures to include bonding, insurance, and other pertinent requirements biannually in an effort to allow Section 3 business concerns the opportunity to take advantage of any upcoming contracting opportunities.
6. Where appropriate, SNRHA will consider breaking out contract work items into economically feasible units to facilitate participation by Section 3 business concerns.
7. Contact area Chambers of Commerce, business assistance agencies, Minority and Women's Business Enterprise (M/WBE) contractor associations and community organizations to inform them of contracting opportunities.
8. Maintain a list of eligible Section 3 business concerns that are certified by SNRHA; review and credential business concerns no less than annually.
9. Participation in opportunities of the Contracting with Resident Owned Businesses Program provided under 24, C.F.R § 963.
10. Utilize SNRHA' s Section 3 Job Development Fund to develop resources, fund training and allowable business expenses to assist residents interested in starting their own businesses.



EMPLOYEE LIST

NAME

FULL SSN

ADDRESS

PHONE#

1.	_____	_____	_____	_____
2.	_____	_____	_____	_____
3.	_____	_____	_____	_____
4.	_____	_____	_____	_____
5.	_____	_____	_____	_____
6.	_____	_____	_____	_____
7.	_____	_____	_____	_____
8.	_____	_____	_____	_____
9.	_____	_____	_____	_____
10.	_____	_____	_____	_____
11.	_____	_____	_____	_____
12.	_____	_____	_____	_____
13.	_____	_____	_____	_____
14.	_____	_____	_____	_____
15.	_____	_____	_____	_____

(Contractor)

By: _____

Title: _____

Signature

Date

Printed Name



ATTACHMENT G

ADDITIONAL CLAUSES

(Keep for your information)

1. Special Conditions
2. Additional Clauses and Requirements
3. Division 1 Information



SPECIAL CONDITIONS

Page 1 of 2

1. COMMUNICATIONS

- (a) All notices, demands, requests, instructions, approvals, proposals, and claims must be in writing.
- (b) Any notice to or demand upon the contractor shall be sufficiently given if delivered at the office of the contractor stated on the signature page of the Contract or at such other office as he may from time to time designate in writing to the SNRHA or deposited in the United States mail in a sealed postage-prepaid envelope, or if delivered with charges prepaid to any telegraph company for transmission, in each case addressed to such office.
- (c) All papers required to be delivered to the SNRHA or architect shall, unless otherwise specified in writing to the contractor, be delivered to the SNRHA and any notice to or demand upon the SNRHA or architect shall be mailed in a sealed, postage-prepaid envelope, or delivered with charges prepaid to any telegraph company for transmission to the SNRHA at such address, or to such other representatives of the SNRHA or to such other address as the SNRHA may subsequently specify in writing to the Contractor for such purpose.
- (d) Any such notice shall be deemed to have been given as of the time of actual delivery; or, in the case of mailing, when the same should have been received in due course of post; or, in case of telegrams, at the time of actual receipt.

2. JOB OFFICES

- (a) The Contractor must designate an area to serve the posting requirements of this contract. A board (4 X 8) must be in plain view in a well-trafficked area at each site. On this board will be posted EEO and wage information in compliance with the General Conditions of this contract.
- (b) For all jobs over \$500,000.00 the Contractor shall furnish and maintain, during construction of the project, adequate facilities at the site to be designated by the SNRHA for the use of the SNRHA and the Architect, as follows: Development/Modernization Director will state the need.
- (c) The Job Office shall include office space of approximately 12' X 12' with light, heat, cold water, toilet facilities, janitor's service, local telephone, plan tables and plan racks, a desk, chair and one four-drawer file cabinet. The Contractor may, at his option, furnish a Job Office trailer that specifically has been designed for that purpose. The trailer, if used, shall be subject to approval by the SNRHA.
- (d) The Contractor and his subcontractors may maintain such office and storage facilities on the site as may be necessary for the proper conduct of the work. These shall be located so as to cause no interference with any work to be performed on the site. The Architect shall be consulted with regard to locations.
- (e) Upon completion of the project, or as directed by the SNRHA or Engineer, the Contractor shall remove all such temporary structures and facilities from the site, same to become his property, and leave the premises in the condition required by the Contractor.

3. MINIMUM RATES OF PAY

Contractor and all subcontractors must meet current state minimum wage requirements.

Per HUD Labor Relations Department, the Contractor is no longer required to contact three (3) contractors in the area who perform this work and request data on wages paid and number of employees.



SPECIAL CONDITIONS

Page 2 of 2

4. EQUIPMENT FURNISHED BY OTHERS

- (a) The following equipment will be furnished by others but installed by the Contractor:

Not Applicable

- (b) The Contractor shall, at his expense and risk, unload and install equipment, and do any necessary hauling to the places for installation. The Contractor shall furnish the SNRHA with a schedule of his need for equipment sufficiently of such need to enable the SNRHA to obtain delivery under the procurement contracts.
- (c) Where the type of equipment requires rough-in dimensions, the Engineer or SNRHA will furnish them to the Contractor as soon as available.
- (d) When equipment arrives at the delivery point, the Contractor shall promptly unload and transfer it to the project site, unless otherwise permitted or directed. The equipment shall not be unloaded except in the presence of a representative of the SNRHA with whom the Contractor shall jointly determine what, if any, damage has occurred in transit, and the responsibility therefore. Turnover of the equipment to the Contractor shall then be formalized by means of a transfer receipt, executed in triplicate, signed by the representatives of the Contractor and the SNRHA. This document shall show all particulars of the shipment it covers, the number and condition of the items turned over to the Contractor shall be fully responsible for the equipment.
- (e) The Contractor shall inspect all equipment items for latent defects or concealed damage and for shortages, and immediately report all such discrepancies to the SNRHA so that correction or replacement can be obtained.
- (f) The provision to "install" as used in paragraph 4.b. above, covers all operations and materials in connection with this equipment necessary to (1) distribute; (2) uncrate; (3) assemble as may be normally necessary; (4) place in permanent position; (5) connect up; and (6) clean up.
- (g) The Contractor shall deliver all such equipment in whole and satisfactory operating condition. He shall be responsible for actions and costs applicable to final testing, adjusting, and checking for proper performance.

5. PERFORMANCE AND PAYMENT BONDS

The company providing the required performance and payment bonds must be listed in U.S. Treasury Circular No. 570 as a surety approved to issue bonds securing Government contracts in the State of Nevada.



ADDITIONAL CLAUSES AND REQUIREMENTS

Page 1 of 17

1. Contract Change Procedures:

a. **Modifications:**

Changes in the work may be accomplished after execution of the contract for construction, if approved by the SNRHA and provided in the Agreement Between Owner and Contractor, and without invalidating the Contract for construction, by Supplemental Instruction or by Change Order, subject to the limitations stated in this Section and elsewhere in the Contract documents.

(1) **A Modification is a:**

(1.a.) **Supplemental Instruction:** Is an order for a minor change in the work issued by the Architect/Professional, involving no changes in the contract amount or contract time, and or a

(1.b.) **Change Order:** Is a written instrument prepared by the Owner and signed by the Owner, contractor and Architect/Professional, stating their agreement upon a change in the work, which results in a change in the Contract time and/or Contract amount.

(2) Changes in the work shall be performed under applicable provisions of the Contract documents and the Contractor shall proceed promptly, unless otherwise provided in the Supplemental Instruction or Change Order.

(3) If the unit prices are stated in the Contract documents or subsequently agreed upon, and if quantities originally contemplated are so changed in a proposed Change Order that application of such unit prices to quantities or work proposed will cause substantial inequity to the Owner or Contractor, the applicable unit prices shall be equitably adjusted.

(4) The amount of credit to be allowed by the Contractor to the Owner for a deletion or change which results in a net decrease in the Contract sum shall be actual net cost as confirmed by the Owner.

b. **Supplemental Instructions:**

The Architect/Professional has the authority, with the approval of the Owner, to order minor changes in the work not involving adjustment in the Contract sum or extension of the Contract time and not inconsistent with the intent of the Contract documents. Such changes shall be affected by written order and shall be binding on the Owner and Contractor. The Contractor shall carry out such written orders promptly.

c. **Changes Orders:**

(1) **Change Order Request:** The Architect/Professional may request a Change Order Request (COR) from the Contractor, which includes a detailed description of a proposed change in the work, with or without supplementary or revised drawings and specifications. Within seven (7) calendar days of the request, the Contractor shall submit the COR to the Architect/Professional, with a statement describing the reasons for the change and the effect on the Contract amount and Contract time, with full documentation. The Contractors COR will include a description of the effect on work separate or other contractors. After review, the Architect/Professional will submit the COR to the Owner, with recommendations. If necessary, the Change Orders costs will be negotiated between the Contractor and Owner, prior to final approval.



ADDITIONAL CLAUSES AND REQUIREMENTS

Page 2 of 17

- (2) **Change Order:** When the Owner and Contractor agree with the adjustments in the Contract amount and Contract time, or otherwise reach agreement upon the adjustments, such agreement shall be effective immediately and shall be recorded in the Change Order prepared by the Owner and executed by all parties.
- (3) **Change Order Procedures:** The Contractor will submit proposals and/or billings for materials and/or labor for all additional work in strict conformance with all provisions, rates and requirements as set forth in the Prevailing Wage Rates outlined in the Construction Contract Documents. The Contractor will submit proposals and/or billings for materials and/or labor with charges limited to those set forth below:
 - (3.1) **Materials:**
 - a. The cost of products or materials to the Contractor or Subcontractor less any applicable trade discount shall be subject to mark-up for overhead and profit, of ten percent (10%).
 - b. The Owner reserves the right to request copies of any or all invoices or contracts, including those from the originating suppliers, subcontractors or manufacturers.
 - c. No overhead and profit will be allowed on taxes.
 - (3.2) **Labor:**
 - a. The General Contractor will be allowed to add a maximum of fifteen percent (15%) overhead and profit in the Change Order labor cost.
 - b. Contractor and Subcontractor labor costs shall be based on current (at time of advertising for bid) prevailing wages rates as approved by the Department of Housing and Urban Development, Labor Relations Department.
 - (3.3) No additional overhead and profit will be allowed for omitting work. When both additions and credits covering related work or substitutions are involved in any one change, the allowance for overhead and profit shall be figured on the basis of the net increase, if any, with respect to that change.
 - (3.4) Any change order submitted that does not meet the above requirements will not be considered by the SNRHA.
- d. **Execution of change orders:** A Change Order will be fully executed by the Owner after the document is signed by the Contractor and the Architect/Professional.
 - (1) Pending full execution of change order, the Contractor may include approved amounts in the Applications for Payment.

2. Claims for Adjustments and Disputes:

- a. Any controversy or claim, excepting artistic effect as generally accepted in the industry, arising out of or relating to the bid process or the performance of a contract, which cannot be resolved by mutual agreement or the protest procedures (including administrative appeal) contained herein, shall, pursuant to NRS 338.150, be settled by arbitration as administered by the Nevada Arbitration Association, at Las Vegas, Nevada, as follows:
 - (1) If the value of the protest, dispute, intended award or contract is less than \$50,000, the dispute shall be settled according to the STREAMLINED ARBITRATION RULES of the Nevada Arbitration Association.



ADDITIONAL CLAUSES AND REQUIREMENTS

Page 3 of 17

- (2) If the value of the protest, dispute, intended award or contract is more than \$50,000.00 the dispute shall be settled according to the CONSTRUCTION, COMMERCIAL AND VOLUNTARY ARBITRATION RULES of the Nevada Arbitration Association. Judgment upon the award rendered by; the arbitrators may be entered into any court having jurisdiction thereof.
- b. In the event that any controversy or claim arising out of or relating to the performance of the bid becomes the subject of arbitration, the Southern Nevada Regional Housing Authority (SNRHA) shall have the right, at its option, to join or bring in any additional party to the arbitration proceeding, and the bidder hereby irrevocably consents and agrees to such joinder.
- c. In the event that the SNRHA is named a party to any arbitration action arising out of, or resulting from the purchase and/or delivery of the services/items specified in this bid, the bidder hereby agrees, at the request of the SNRHA, to be joined as a party to the arbitration proceeding and to be bound by any decision resulting from arbitration.
- d. None of the time provisions imposed apply to the joinder rights provided herein in such a way as to preclude the SNRHA from joining the bidder as a party to any arbitration proceeding in which it is named and which arises out of, or results from, the purchase and/or delivery of the services/items specified in this bid.
- e. In order for the bidder to be able to arbitrate any claim, dispute or other matter in question between the parties, written notice must be given to the SNRHA within thirty (30) calendar days after the claim, dispute or other matter arises. In order for the SNRHA to be able to arbitrate any claim, dispute or other matter in question between the parties, written notice must be given to the bidder within sixty (60) calendar days after the claim, dispute or other matter arises. The purpose of such notification is to place the other party on notice so that proper measures can be taken to properly defend against such claim, dispute or other matter, and the failure to give such notice shall preclude the party desiring arbitration from subsequently arbitrating that particular claim, dispute or other matter.
- f. The filing of this written notice shall preserve that party's right to arbitrate, but shall not obligate the party to proceed with arbitration. In the event that either party desires to proceed with the arbitration of a claim, dispute, or other matter with respect to which such notice has been given, a written demand for arbitration shall be filed in writing with the other party within sixty (60) calendar days after the ending of the contract, and failure to make such demand shall forever bar such claim from being arbitrated.
- g. In the event of arbitration, it is agreed by the parties that all means of discovery, including but not limited to depositions and interrogatories, will be afforded to the parties involved in the arbitration, and the appointed arbitrator(s) shall have all authority to impose sanctions against either party for failing to comply with the rules for discovery provided under the Nevada Rules of Civil Procedure.
- h. Within ten (10) calendar days after written receipt by either party of the other's intention to arbitrate, both parties shall each select an arbitrator of their own choosing which shall be uncontestable by the other party.
- i. The two-(2) uncontestable arbitrators shall attempt to select a third arbitrator who shall be as neutral as unmanly possible. The third arbitrator should not be actively involved in an industry directly involved in the items, materials or services to be purchased under this contract. The background of the third arbitrator should be of broad general business, preferably in a senior management position.



ADDITIONAL CLAUSES AND REQUIREMENTS

Page 4 of 17

- j. If a third suitable arbitrator cannot be found by the two uncontestable arbitrators within fifteen (15) calendar days after the first being selected, then either party may, in writing, make application to the Eighth Judicial District Court in accordance with NRS 38.005 for an appointment of the third arbitrator.
- k. Upon appointment of the third arbitrator, all three (3) arbitrators shall commence within five (5) calendar days after that appointment to commence reaching a determination of the dispute, under the applicable industry rules of the American Arbitration Association.
- l. The award rendered by the arbitrator(s) shall be final, and judgment may be entered upon it in accordance with applicable law in any court having jurisdiction thereof.
- m. If the contract is still in force, the contractor shall carry the work and maintain progress during any arbitration, court proceedings or other disputes excluding those contained in this section, unless otherwise mutually agreed upon in writing. The arbitration shall be conducted in accordance with all Bid Documents.

3. Default:

The SNRHA may, subject to the provisions outlined below, terminate the whole or any part of the contract in any one of the following circumstances, by written thirty (30) calendar days' notice of default to the contractor:

- (1) If the contractor fails to perform the service(s) within the time specified herein or any extension thereof; or
- (2) If the contractor fails to perform any of the provisions of the contract, or so fails to make progress as to endanger performance of the contract in accordance with its terms, and in either of these two circumstances does not cure such failure within the requirements set forth in the Bid Documents; or
- (3) In the event the contractor is unable to tender performance on the date, time, and location specified by the SNRHA, the contractor agrees to pay the SNRHA an amount equal to the actual costs incurred by the SNRHA in replacing the contractor's services. Indemnification shall be made for the time the contractor fails to perform under the terms and conditions of the contract. In addition to the above payments, damages arising from the contractor's failure to perform will apply in all cases except where failure to perform arises out of causes beyond the control and without fault or negligence of the contractor.
- (4) Except with the respect to defaults of the subcontractors, the contractor shall not be liable for any excess costs if the failure to perform the contract arises out of causes beyond the control without the fault or negligence of the contractor. Such causes may include, but are not limited to, acts of God or of the public enemy, acts of the SNRHA, in either its sovereign or contractual capacity, acts of the Federal, State or local governments in their sovereign capacity, fires, floods, epidemics, quarantine restrictions, strikes, freight embargoes, and unusually severe weather; but in every case the failure to perform must be beyond the control and without the fault of the contractor.
- (5) If the failure to perform is caused by the default of a subcontractor, and if such default arises out of causes beyond the control of both the contractor and subcontractor, and without the negligence of either of them, the contractor shall both be liable for any excess costs for failure to perform, unless the supplies or services to be furnished by the subcontractors were obtainable from other sources in sufficient time to permit the contractor to meet the required delivery and/or installation schedule.



ADDITIONAL CLAUSES AND REQUIREMENTS

Page 5 of 17

4. Termination For Convenience of the SNRHA:

- a. The performance of work under the contract may be terminated by the SNRHA in whole or in part from time to time, upon at least a thirty (30) calendar day written notice to the contractor or successful bidder when such action is deemed by the SNRHA to be in its best interest. Termination of work shall be affected by delivery to the contractor of a Notice of Termination specifying the extent to which performance of work under the contract is terminated, and the date upon which such termination becomes effective.
- b. After receipt of the Notice of Termination and except as otherwise directed by the SNRHA, the contractor shall:
 - (1) Stop work under the contract on the date and to the extent specified in the Notice of Termination.
 - (2) Complete performance of such part of the work as shall not have been terminated by the Notice of Termination.
- c. After receipt of a Notice of Termination, contractor shall submit to the SNRHA, in the form and with the certification as may be prescribed by the SNRHA, a termination claim and invoice.
- d. Such claim and invoice shall be submitted promptly, but not later than thirty (30) days from the effective date of termination. Upon failure of contractor to submit his/her termination claim and invoice within the time allowed, the SNRHA may determine on the basis of information available to the SNRHA, the amount, if any, due the contractor in respect to the termination, and such determination shall be final. After such determination is made, the SNRHA shall pay the contractor the amount determined.
- e. The contractor, for a period of five (5) years after the final settlement under the contract, shall make available to the SNRHA, at all reasonable times, at the office of the contractor, all his books, records, documents, or other evidence bearing on the costs and expenses of the contractor, under the contract in respect to the termination of the work.

5. Notification:

- a. Notices to the contractor shall be addressed to his/her place of business as designated on the Form of Bid, or such other place as may be designated in writing by the contractor.
- b. Unless otherwise specified in the Technical Specifications, notices to the SNRHA shall be addressed to:

Southern Nevada Regional Housing Authority
Linda P. Simpson
Contracts Administrator
340 N. 11th Street Suite 180
Las Vegas, NV 89101-3611
Telephone: (702) 477-3144 ■ Fax: (702) 922-6648 ■ TDD: (702) 387-1898

- c. In the event of suspension or termination of the contract, the notices may also be given by the SNRHA upon personal delivery to any person whose action or knowledge of such suspension or termination would be sufficient notice to the contractor.



ADDITIONAL CLAUSES AND REQUIREMENTS

Page 6 of 17

6. Delays and Time Extensions: The contractor is responsible for completing the work within the time established in the contract. The SNRHA is responsible for monitoring the contractor to ensure that work will be completed as scheduled. The SNRHA may authorize justifiable time extensions without prior HUD review and approval, unless the SNRHA is subject to prior HUD approval under a HUD-established threshold that is less than the requested amount. The "Default" clause on the forms HUD-53700, 5370-C and 5370-EZ prescribe the conditions under which a time extension may be granted. The basic principle is that delays arising from unforeseeable causes beyond the control and without the fault or negligence of the contractor may be grounds for allowing a time extension. Such time extensions should be formalized in a written modification to the contract.
7. Time Extension Criteria: In order to be considered for approval by the SNRHA, requests for time extensions should meet the following criteria:
 - a. The contractor should submit a written notice to the SNRHA within (10) calendar days of the start of any delay;
 - b. The severity and extent of adverse weather could not have been reasonably foreseen by the contractor (normal seasonal levels of rain, snow, cold or heat should have been considered by the contractor); and
 - c. The cause of the delay was beyond the contractor's control.
8. Documentation: Immediately upon receipt of the contractor's notification of delay or request for time extension, the SNRHA shall send a letter of acknowledgement to the contractor. The letter will indicate that either: (1) immediate consideration will be given to the contractor's request or (2) the actual delay in work is difficult to determine and consideration will be given to the contractor's request upon completion of work.

SNRHA staff will review the records to ensure that the information provided by the contractor is accurate and complete. This will allow the Contracting Officer to determine the cause of the delay and the extent that it was within the Contractor's control. It will also determine if the request meets the contract's criteria for approving or rejecting the request for a time extension. Two criteria for approval of time extension request follow:

- a. The contractor's request, as documented by the SNRHA "finding of fact," meets the requirements stated in "Documentation" above, and
 - b. The additional time requested by the contractor is reasonable based on the nature and duration of the delay.
9. Liquidated Damages for Failure to Perform:
 - a. The SNRHA depends upon the availability and functionality of the services and/or materials as outlined in the Bid Documents for the purposes of conducting necessary business.
 - b. It is virtually impossible to accurately define the exact amount of financial loss the SNRHA would incur if the services and/or materials as outlined in the Bid Documents become unavailable for use. However, the SNRHA should not be subject to financial indebtedness if in fact the services and/or materials as outlined in the bid are not provided.
 - c. Criteria for the contractor's failure to perform and the liquidated damages to be addressed are indicated below:
 - (1) Unavailability of the services and/or materials as defined as not being delivered for the SNRHA business use within the time the contractor promises the services and/or materials will be available.
 - (2) Acts of God is the only reason that may excuse the contractor from being assessed liquidated damages.



ADDITIONAL CLAUSES AND REQUIREMENTS

Page 7 of 17

- (3) Liquidated damages will be assessed in the amounts indicated in the bid documents. The final amount shall be deducted from the contractor's monthly billing for services and/or materials up to a maximum of the total monthly amount of service. If billing is not handled on a monthly basis, the amount due to the SNRHA may be subtracted from any billing invoice submitted to the SNRHA for payment by the contractor.

10. Joinder Privileges - N.R.S. 332:

- a. Pursuant to Nevada Revised Statute 332.195, the State of Nevada and/or any political subdivision within the State of Nevada may be granted the privilege of joining the awarded contract, at the option of the successful bidder ONLY. If the successful bidder so grants such a privilege, the terms and conditions of the Bid Documents may be passed on to the joining political subdivision by the successful bidder.
- b. The successful bidder shall retain the unilateral right to allow or disallow any political subdivision the privilege of joining the awarded contract. In the event the successful bidder allows another political subdivision to join the SNRHA contract, it is expressly understood that the SNRHA shall in no way be liable for the joining political subdivision obligations to the successful bidder in any manner whatsoever.

11. Billing Method:

Billings for services and/or materials awarded under the provisions of the Bid Documents will commence on the day on which such services and/or materials are activated and used by the SNRHA. Services shall be provided and billed as instructed in the Technical Specifications.

12. Disputed Billings (Charges):

In the event that the SNRHA disputes any portion of the billing(s), the SNRHA shall obey the undisputed portion of such billing and initiate the dispute-resolving procedures, as follows:

- (1) Should the SNRHA dispute a portion of any of its billing(s), its representative shall, within thirty (30) calendar days after the SNRHA's receipt of such billing, informally notify the contractor's designated representative that such dispute exists. Such dispute shall be resolved in accordance with the contractor's customary informal dispute resolution process.
- (2) If such dispute cannot be resolved by the contractor's customary informal dispute resolution process, within ten (10) calendar days after such notification is given, the SNRHA's Purchasing Agent and the contractor's local Manager shall meet to discuss the matter.
- (3) If the SNRHA Purchasing Agent and the contractor's local Manager are unable to resolve the dispute through such discussion within ten (10) calendar days, the SNRHA shall, within ten (10) calendar days thereafter, either:
 - (a) Pay the disputed charges and reserve the right to submit the matter to arbitration, as called for under Section D., Paragraph 1., Claims For Adjustments and Disputes.
 - (b) Not pay the disputed charge and submit the matter to arbitration, as referred to in the preceding paragraph above.
- (4) As stated previously, the decision from arbitration will be binding upon both parties. If the decision is adverse to the SNRHA, the SNRHA shall pay the amount, which is ordered, to the contractor within ten (10) calendar days after the SNRHA's receipt of the decision. If the decision is in favor of the SNRHA, the contractor will either; (a) clear the amount which is ordered from the SNRHA account, or (b) repay to the SNRHA the amount ordered; either option within ten (10) calendar days after the contractor's receipt of decision.



ADDITIONAL CLAUSES AND REQUIREMENTS

Page 8 of 17

13. Non-Escalation:

Unless otherwise specified in the Technical Specifications, the unit prices reflected on the Form of Bid shall remain firm with **NO** provision for price increases during the term of the contract.

14. Funding Restrictions and Order Quantities:

The SNRHA reserves the right to reduce or increase estimated or actual quantities in whatever amount necessary without prejudice or liability to the SNRHA, if:

- (1) Funding is not available.
- (2) Legal restrictions are placed upon the expenditure of monies for this category of service or supplies; or,
- (3) The SNRHA's requirements in good faith change after award of the contract.

15. Licensing, SIIS, Insurance Permits:

- a. At the time of bid award, all prospective bidders shall be duly licensed in accordance with all applicable statutes/codes of the State of Nevada and the City and County having jurisdiction.
- b. A business license, from the jurisdiction the property is located at, allowing the prospective bidder to conduct and/or supply the services and/or materials described in these Bid Documents shall also be required of all prospective bidders at the time of bid award (proof of pending applications is acceptable)
- c. Should the successful bidder intend to sublet portions of the work (if expressly allowed by the SNRHA), it shall be the responsibility of the successful bidder to insure that all sub-bidders also be properly licensed in accordance with the aforesaid State statutes and applicable City/County codes.
- d. At the time of bid submittal, prospective bidders utilizing employees shall be duly registered with the State of Nevada Industrial Insurance System (SIIS) and the State of Nevada Employment Security Department and shall be current in their payments and coverage for both. Award cannot be made to any apparent successful bidder unless he/she meets this requirement. It shall be the responsibility of the successful bidder to ensure that all sub-bidders also meet this requirement.

NOTE: Copies of the above named documents (City and County business license; State of Nevada SIIS and State Employment Certificates of Coverage; and other local, State, County or Federal licenses or certifications as may be required for this bid) will be required from the successful bidder before award can be made. Failure to submit these documents shall cause that bidder not to be considered for Award.

- e. Prior to contract approval and up to project acceptance by the owner, the successful bidder shall furnish at its own expense to the SNRHA a certificate of insurance evidencing that Builder's Risk (fire and extended coverage) insurance on all work in place and/or materials stored at the building sites(s). The SNRHA's existing fire and extended coverage policy may not be endorsed for any work under this contract.

The contractor shall provide the SNRHA with current certificate(s)/endorsement(s) evidencing the insurance coverage indicated in the bid documents.

Failure by the successful bidder to submit such documents as instructed shall, at the discretion of the SNRHA Dev/Mod Director, allow that bidder to be eliminated from consideration for the award of Bid and allow the SNRHA to make Award to the next lowest bidder, as long as he/she are able to comply with the Specifications and requirements of the Bid.



ADDITIONAL CLAUSES AND REQUIREMENTS

Page 9 of 17

- f. Unless otherwise stated in the Bid Documents, all local, City or County, State or Federal permits which may be required by this bid, whether or not they are known to either the SNRHA or the bidders at the time of Bid Opening or Bid Award, shall be the sole responsibility to the successful bidder, and any bid sums submitted on the Form of Bid shall reflect all costs required by the successful bidder to procure and provide such necessary permits.

16. Taxes:

All persons doing business with the SNRHA should be aware that the SNRHA is exempt from paying Nevada State Sales and Use Taxes and Federal Excise Taxes. **This tax exemption status is not extended for use by professional or contractors.** A letter of Tax Exemption will be provided to the successful bidder upon request.

17. State Statutes:

Prospective bidders are advised they must observe all State and Federal statutes regarding minimum wage rates, NRS 338, equal employment opportunity, Copeland Anti-Kickback Act, etc. Each and every provision of Chapter 332 of the NRS and other laws required to be inserted in these Bid Documents shall be deemed to be inserted herein and finalized contract shall be read and enforced as though it were included therein, and if through mistake or otherwise any such provision is not inserted, or is not correctly inserted, then upon the application of either party the contract shall be physically amended to make such insertion or correction.

18. Government Standards:

It is the responsibility of the prospective bidder that all items and services submitted for bid conform to all local, State, and Federal law concerning safety (OSHA and NOSHA) and environmental control (EPA and Clark County Pollution regulations). The successful bidder shall be responsible for all costs incurred for compliance with these possible ordinances, requirements or laws. No time extensions shall be granted or financial consideration given to the successful bidder for time or monies lost due to violations of these regulations.

19. Freight On Bill and Delivery:

- a. All bid prices submitted shall reflect the cost of delivering the bidded services and/or materials to the location(s) specified within the Bid Documents or on the contract.
- b. The successful bidder agrees to deliver to the designated location(s) on or before the date as specified in the finalized contract. Failure to deliver on or before the specified date constitutes an event of default by the successful bidder. Upon default, the successful bidder agrees that the SNRHA may, at its option, rescind the finalized contract under the DEFAULT CLAUSE of these Instructions and seek compensatory damages as provided by law.

20. Backorders:

The SNRHA Development/Modernization Director or his/her designated alternate, must be notified within five (5) calendar days of all backordered materials and/or incomplete services, and the estimated date delivery and receipt is to be made. Unless otherwise stipulated in the contract, any order that will take over a maximum of fourteen (14) days past the original agreed upon delivery date may, at the option of the SNRHA, be canceled and ordered from another source, if, in the opinion of the SNRHA Development/Modernization Director, it is in the best interest of the SNRHA to do so.



ADDITIONAL CLAUSES AND REQUIREMENTS

Page 10 of 17

21. Contract Extension:

Unless otherwise stated within the Bid Documents, the SNRHA shall retain the right to, at the end of the original contract, extend the contract up to a maximum of the length of the original contract (i.e.: 1 year original contract = 1-year possible maximum extension of same contract). This shall be possible only if the successful bidder agrees not to raise any individual or total bid sums, unless the original contract sums were allowed to change based on a Price Adjustment Provision contained in the original contract; and that no other changes may be made to the original agreement, except at the SNRHA's discretion.

22. Literature:

Prospective bidders may be required to furnish, either as part of their sealed bid or at another specified time during the bid, specification sheets, brochures, product literature, or other such materials which contain sufficient data to enable the SNRHA staff to properly evaluate the items being submitted for bid consideration. Failure to enclose such data, if required, may cause rejection of that bid without consideration. If the prospective bidder has a question as to whether or not such materials should be submitted, it shall be their responsibility to make inquiry of the SNRHA Development/Modernization Director.

23. Training:

If requested by the SNRHA, the successful bidder shall provide a qualified factory-trained instructor for up to eight (8) hours or more of theory and practical instruction. The training shall be equivalent to that provided to the manufacturer's field service personnel. **NOTE:** This paragraph applies mainly to bids concerning machinery and equipment; however, shorter instruction periods may be required for other items. The required instruction time may be specified in the Technical Specifications.

24. Instruction Manuals:

If requested by the SNRHA, the successful bidder shall furnish, at no additional cost to the SNRHA, two (2) complete instruction manuals and parts breakdowns upon delivery of the bidded items.

25. Communication:

If during the period of the contract it is necessary that the SNRHA place toll or long distance telephone calls or telegrams in connection therewith (for complaints, adjustments, shortages, failure to deliver, etc.), it is understood that the successful bidder will bear the charge or expense for all such calls/telegrams.

26. Work On Authority Property:

If the successful bidder's work under this bid involves operations by the successful bidder on SNRHA premises, the successful bidder shall take all necessary precautions to prevent the occurrence of any injury to persons or property during the progress of such work, and except to the extent that any such injury is caused solely and directly by the SNRHA's negligence, shall indemnify the SNRHA, and their officers, agents, servants and employees against all loss which may result in any way from any act or omission of the successful bidder, its agents, employees, or subcontractors; and the successful bidder shall maintain such public liability, property damage and employer's liability and compensation insurance as will protect the SNRHA from said risks and from any claims, any applicable workmen's compensation and occupational disease acts.



ADDITIONAL CLAUSES AND REQUIREMENTS

Page 11 of 17

27. Estimated Quantities:

Unless otherwise indicated the quantities reflected on the Bid Documents, to the best of the SNRHA's knowledge, reflect projected consumption date. These quantities are not meant to infer or imply actual consumption figures or quantities that will be purchased by the SNRHA under the finalized contract; but, pursuant to all Bid Documents, these quantities will be used to determine the successful bidder.

28. Record Retention and Inspection:

- a. The successful bidder agrees that the SNRHA or any duly authorized representative shall have access to and the right to examine, audit, excerpt, copy or transcribe any pertinent transaction, activity, time cards, or other records relating to this proposed contract. Such material, including all pertinent costs, accounting, financial records and proprietary data, must be kept and maintained by the contractor in a location within Clark County, Nevada, for a period of five (5) years after completion of this contract unless the SNRHA's written permission is obtained to dispose of said materials prior to this time.
- b. If, at any time during the term of the contract, or at any time after the expiration or termination of the contract, authorized representatives of the SNRHA conduct an audit of the contractor's records regarding the service provided to the SNRHA, and if such audit finds the SNRHA's dollar liability for such service is less than payments made by the SNRHA to the contractor; then the contractor agrees that the difference shall be either; (1) repaid immediately by the contractor to the SNRHA by cash payment, or (2) at the SNRHA's option, credited against any future payment to the contractor.

29. Warranty:

- a. The services/materials provided under this bid shall conform to all information contained within these Bid Documents as well as all applicable Industry Published Technical Specifications, and if one of the above mentioned Specifications contain more stringent requirements than the other, the more stringent requirements shall apply.
- b. Unless otherwise indicated in the Technical Specifications, all materials, workmanship and title shall be guaranteed by the successful bidder to be free of defects for a period of one (1) calendar year from the date of acceptance by the SNRHA.
- c. All freight cost incurred for shipment to and from the contractors designated place of business to correct warranty defects during the warranty period shall be borne by the successful bidder.
- d. The liability of the successful bidder to the SNRHA (except as to title) arising out of the furnishing of the goods and/or services or of its use under the terms of the contract shall not exceed the correcting of the defect(s) in the goods and/or services as provided under the contract, and upon expiration of the warranty period all such liability shall terminate EXCEPT UNDER THE WARRANTY FOR MERCHANTABILITY AND THE WARRANTY OF FITNESS FOR A PARTICULAR PURPOSE.

30. Warranty Exclusions Prohibited:

- a. The SNRHA will NOT accept any warranty clause from either the successful bidder or from a manufacturer, which states:
 - (1) That the warranty of merchantability and/or the warranty of fitness for a particular purpose is excluded from the offer to the SNRHA.
 - (2) That the manufacturer's and/or successful bidders warranty is in lieu of all other warranties that are either expressed or implied.



ADDITIONAL CLAUSES AND REQUIREMENTS

Page 12 of 17

- b. In addition to the above restrictions, the warranty requirements of the Bid Documents shall run from the manufacturer to the SNRHA as well as from the successful bidder to the SNRHA if the goods/services are sold by a distributor or agent.

31. Correction of Warranty Defects:

- a. If required by the Bid Documents, the successful bidder shall, within five (5) calendar days after the Bid Opening and prior to the delivery of the goods and/or services, appoint a firm in the immediate Las Vegas area of his/her own choosing who will be the immediate contact point for the correction of warranty defects.
- b. Unless otherwise stated in the Conditions/Specifications, the local firm shall address and correct any warranty defects within twenty-four (24) hours of notification. Any warranty defect that requires more than twenty-four (24) hours to correct shall require the direct intervention by the successful bidder and must be corrected within ten (10) calendar days after notification by the SNRHA.
- c. Failure to comply with the requirements of the provisions of this provision (No. 27) shall be just cause for the SNRHA declaring the contract in default under the Default Clause of these Instructions, and shall allow the SNRHA to seek remedy at law.

32. Official, Agent and Employees of the SNRHA Not Personally Liable:

It is agreed by and between the parties hereto that in no event shall any official, officer, employee, or agent of the Southern Nevada Regional Housing Authority, in any way be personally liable or responsible for any covenant or agreement herein contained whether expressed or implied, nor for any statement, representation or warranty made herein or in any connection with this agreement.

33. Subcontractors:

Unless otherwise stated within the bid documents, the successful bidder may not use any subcontractors to accomplish any portion of the services described within the Technical Specifications without the prior written permission of the SNRHA's Development/Modernization Director.

34. Salaries and Expenses Relating to the Successful Bidders Employees:

Unless otherwise stated within the Bid Documents, the successful bidder shall pay all salaries and expenses of, and all Federal, Social Security taxes, Federal and State Unemployment taxes, and any similar taxes relating to its employees used in the performance of this contract. The successful bidder further agrees to comply with all Federal, State and local wage and hour laws and all licensing laws applicable to its employees or other personnel furnished under this agreement.

35. Attorney's Fees:

In the event that litigation is commenced by one party hereto against the other in connection with the enforcement of any provision of this agreement, the prevailing party shall be paid by the losing party all court costs and other expenses of such litigation, including attorney's fees, in a reasonable amount, to be determined by the court. The amount so allowed as attorneys' fees shall be taxed to the losing party as costs of the suit, unless prohibited by law.

36. Independent Contractor:

The successful bidder is an independent contractor. Nothing herein shall create any association, agency, partnership or joint venture between the parties hereto and neither shall have any authority to bind the other in any way.

37. Severability:

If any provision of this agreement or any portion or provision hereof applicable to any particular situation or circumstance is held valid, the remainder of this agreement of the remainder of such provision (as the case may be), and the application thereof to other situations or circumstances shall not be affected thereby.



ADDITIONAL CLAUSES AND REQUIREMENTS

Page 13 of 17

38. Waiver of Breach:

A waiver of either party of any terms or condition of this agreement in any instance shall not be deemed or construed as a waiver of such term of condition for the future, or of any subsequent breach thereof. All remedies, rights, undertakings, obligations, and agreements contained in this agreement shall be cumulative and none of them shall be in limitation of any other remedy, right, obligation or agreement of either party.

39. Time of the Essence:

Time is of the essence under this agreement as to each provision in which time of performance is a factor.

40. Limitation of Liability:

In no event shall the SNRHA be liable to the successful bidder for any indirect, incidental, consequential or exemplary damages.

41. Indemnity:

a. The successful bidder shall protect, indemnify and hold the SNRHA its officers, employees, agents, consulting engineers and other retained consultants harmless from and against any and all claims, damages, losses, suits, actions, decrees, judgments, attorney's fees, court costs and other expenses of any kind or character which the SNRHA, its officers, employees, agents, consulting engineers or other retained consultants may suffer, or which may be sought against, recovered from or obtainable against the SNRHA, its officers, employees, agents, consulting engineers or other retained consultants (i) as a result of, or by reason of, or arising out of, or on account of, or in consequence of the operations of the successful bidder, its subcontractors or agents, or anyone directly or indirectly employed by any subcontractor or agent, in the fulfillment or performance of the terms, conditions or covenants of the contract or agreement, regardless of whether or not the occurrence which gave rise to such claim, damage, loss, suit, action, judgment or expense was caused, in part, by the party indemnified hereunder; or (ii) as a result of, or by reason of, or arising out of, or on account of, or in consequence of, any neglect in safeguarding the work; or (iii) through the use of unacceptable materials and/or products which may be defective or manufactured, designed or installed so as to give rise to a claim; or (iv) because of any claim or amount recovered under the "Nevada Industrial Insurance Act", or any other law, ordinance, or decree. Any money due the successful bidder under and by virtue of the contract which is considered necessary by the SNRHA for such purpose, may be retained by the SNRHA for its protection; or in case no money is due, its surety may be held until all such claims, damages, losses, suits, actions, decrees, judgments, attorney's fees and court costs and other expenses of any kind or character as aforesaid shall have been settled and suitable evidence to that effect furnished to the SNRHA; provided, however, that money due the successful bidder will not be withheld when the successful bidder produces satisfactory evidence that is adequately protected by public liability and property damage insurance, if required.

b. In this connection, it is expressly agreed that the successful bidder shall, at its own expense, defend the SNRHA, its officers, employees, agents, consulting engineers and other retained consultants, against any and all claims, suits or actions which may be brought against them, as a result of, or by reason of, or arising out of, or on account of, or in consequence of any act or omission against which

the successful bidder shall fail to do so, the SNRHA shall have the right, but not the obligation, to defend the same and to charge all direct and incidental costs of such defense to the successful bidder including attorney's fees and court costs.

c. Reimbursement to the successful bidder by the SNRHA, in whole or in part, for the costs of protecting traffic shall not serve to relieve the successful bidder of its responsibility as set forth in the Bid Documents.



ADDITIONAL CLAUSES AND REQUIREMENTS

Page 14 of 17

- d. The successful bidder guarantees the payment of all just claims for materials, supplies and labor, and all other just claims against it or any subcontractor, in connection with the contract.

42. Lobbying Certification:

By proposing to do business with the SNRHA or by doing business with the SNRHA, each bidder certifies that:

- a. No Federal appropriated funds have been paid or will be paid, by or on behalf of the bidder, to any person for influencing or attempting to influence an officer or employee of an agency, a Member of Congress, an officer or employee of Congress, or an employee of a Member of Congress in connection with the awarding of any Federal contract, the making of any Federal grant, the making of any Federal loan, the entering into of any cooperative agreement, and the extension, continuation, renewal, amendment or modification of any Federal contract, grant, loan, or cooperative agreement.
- b. If any funds other than Federal appropriated funds have been paid or will be paid to any person for influencing or attempting to influence an officer or employee of any agency, a Member of Congress, an officer or employee of Congress, or an employee of a Member of Congress in connection with this Federal contract, grant, loan, or cooperative agreement, the bidder shall complete and submit standard Form-LLL, "Disclosure Form to Report Lobbying", in accordance with its instructions.
- c. The successful bidder shall require that the language of this certification be included in the award documents for all subawards at all tiers (including subcontracts, subgrants, and contracts under grants, loans, and cooperative agreements) and that all subrecipients shall certify and disclose accordingly.
- d. This clause is a material representation of fact upon which reliance was placed when the award was made or entered into. The signing of a contract or acceptance of award certifies compliance with this certification, which is a prerequisite for making or entering into a contract which is imposed by section 1352, Title 31, U.S. code. Any person who fails to file the required certifications shall be subject to civil penalty of not less than \$10,000 and not more than \$100,000 for each such failure.

43. Bonding:

- a. As may be required by these Instruction or the Specifications, each bidder, successful bidder, of contractor may be required to provide one or more of a variety of bonds. Any bid bonds required must be delivered with the bid submittal. Unless otherwise stated within the Specifications or addenda, all other bonds must be delivered to the SNRHA within ten (10) days of receipt of notice from the SNRHA. If the bidder, successful bidder or contractor fails to deliver such required bond by the tenth calendar day after receipt of notice from the SNRHA, he/she shall pay to the SNRHA the amount of \$250.00 per day as liquidated damages. If the bidder, successful bidder, or contractor does not keep the required bonds or insurance policies in effect or allows such to lapse, he/she shall pay to the SNRHA the amount of \$500.00 per day in liquidated damages. If the Specifications does not require any bond to be submitted, then these Instructions shall not require such bond; however, if the Specifications do require a bond to be submitted this bonding clause shall be in effect.

BRIEF DESCRIPTION OF VARIOUS TYPES OF BONDS THAT MAY BE REQUIRED:

- b. The BID BOND shall guarantee to the SNRHA that the bidder shall enter into a contract to provide the required goods or services at the prices and conditions contained within the bid documents, and shall guarantee that the bidder shall provide a performance bond or other required bond if award is to be made to that bidder. The amount of the bid bond may vary from one bid to another.



ADDITIONAL CLAUSES AND REQUIREMENTS

Page 15 of 17

- c. The PERFORMANCE BOND shall guarantee to the SNRHA that the successful bidder or contractor shall perform and complete the work as detailed within and required by the bid documents. Unless otherwise stated within the Specifications or addenda, this bond shall be in the amount of 100% of the contract price or value.
- d. The LABOR AND MATERIAL BOND shall guarantee to the SNRHA that the successful bidder or contractor shall pay all labor and materials obligations that he/she incurs as a result of performing the requirements of the bid documents and/or contract.
- e. The GUARANTY BOND shall guarantee to the SNRHA that the successful bidder or contractor shall guarantee for a period of not less than one (1) year that (a) all workmanship provided by his/her firm or any subcontractors used shall be free of defect; and (b) all materials or equipment installed or provided shall be free of fault and shall perform in such a manner as to meet the Specifications and requirements of the bid documents or contract.
- f. Form of Bonds: All bonds submitted to the SNRHA shall be written on the forms supplied by the SNRHA; and no changes or additions may be made to these forms without the written consent of the SNRHA Purchasing Agent. The bidder shall require the attorney-in-fact who executes the required bond on behalf of the surety to affix thereto a certified and current copy of his/her power of attorney. Pursuant to NRS 680A.300, any bond prepared by a licensed nonresident agent must be countersigned by a resident agent.

44. Debarment and Suspension.

Contractor agrees, by submitting this bid, to include this clause without modification in all lower tier transactions, solicitations, bids, contracts and subcontracts.

- a. By submitting this bid to SNRHA, the contractor hereby certifies that neither it nor its principals are presently debarred, suspended, proposed for debarment, declared ineligible, or voluntarily excluded from participation in this transaction by any federal department or agency. This certification is made pursuant to the regulations implementing Executive Order 12549, Debarment and Suspension, 28 C.F.R., pt. 67 § 67.510, as published as pt. VII of the May 26, 1988, Federal Register (pp. 19610-19211), and any relevant program-specific regulations.
- b. Contractor acknowledges and agrees that, pursuant to Federal Acquisition Regulation (FAR) 9.406-2, the SNRHA has discretion to suspend and/or debar contractor from conducting future business with the SNRHA for contractor's commission of the offenses outlined in FAR 9.406-2, including, but not limited to, violation of any applicable Federal law, commission of fraud, embezzlement and/or theft, receipt of stolen property, sue of inappropriate construction materials, repeated contract violations and recurrent re-inspections. The SNRHA's right to suspend and/or debar contractor is in addition to the SNRHA's right to assess the monetary penalties outlined in Paragraph 44(b)(1).
 - (1) Contractor acknowledges and agrees that the SNRHA may assess a monetary penalty for a third, and any subsequent punch-list inspection caused by Contractor's negligence or willful disregard in failing to complete Contractor's scope of work by the initial, or secondary punch-list inspection date assigned by the SNRHA or any other local or state governing body. The penalty for a third, and any subsequent punch-list inspection shall be a \$200 re-inspection appointment fee plus a \$75 per hour services fee plus any overtime fees, if applicable. The monetary penalty shall be paid by Contractor to the SNRHA, or deducted by the SNRHA from the contractor's owed balance under the contract.



ADDITIONAL CLAUSES AND REQUIREMENTS

Page 16 of 17

46. Ethics in Public Contracting: Ethical standards apply not only to PHA employees and Contracting Officers but to others with a vested interest in PHA contracts such as members of the Board of Commissioners, other officials and agents of the authority, and contractors with whom the PHA does business. Please refer to Handbook No. 7460.8 Rev 2, Chapter 4, which explains the specific ethical requirements for PHA contracting 24 CFR 85.36 (b)(3).
1. Principles: Members of the Board of Commissioners, PHA employees, and any others serving in an official position or acting as an agent of the PHA (hereafter referred to as employees, officers, or agents) must discharge their duties impartially to ensure fair competitive access to procurement opportunities by responsible contractors. Moreover, employees, officers, and agents should conduct themselves in such a manner as to foster the public's confidence in the integrity of the PHA procurement organization and process. Any attempt to realize personal gain through PHA employment or to serve as an officer or agent of the PHA through actions inconsistent with the proper discharge of duties is a breach of public trust.
 2. Conflicts of Interest (24 CFR 85.36(b)(3) and Section 19 of the Annual Contribution Contract (ACC) between HUD and Public Housing: PHAs must observe the following conflict of interest prohibitions.
 - a. No PHA employee, officer, or agent shall participate in the selection, award or administration of a contract supported by Federal funds if a conflict of interest, financial or otherwise, real or apparent, would be involved. Such a conflict would arise when the employee, officer or agent, any member of his or her immediate family; his or her partner; or an organization which employs or is about to employ any of the above, has a financial or other interest in the firm selected for the award.
 - b. Immediate family is defined as: father, mother, sister, brother, son, daughter, wife, husband, grandparents, stepparents, in-law, sister-in-law, son-in-law, daughter-in-law, uncle and aunt and legal guardian and legal ward. Uncle and Aunt shall be defined as brother and sister of your biological father or mother.
 - c. In addition to any other applicable conflict of interest requirements, neither the PHA nor any of its contractors or their subcontractors may enter into any contract, subcontract, or arrangement in connection with a project under the ACC in which any of the following classes of people have an interest, direct or indirect, during his or her tenure or for one year thereafter:
 - i. Any present or former member or officer of the governing body of the PHA, or any member of the officer's immediate family. There shall be excepted from this prohibition any present or former tenant commissioner who does not serve on the governing body of a resident corporation, and who otherwise does not occupy a policymaking position with the resident corporation, the PHA or a business entity.
 - ii. Any employee of the PHA who formulates policy or who influences decisions with respect to the project(s), or any member of the employee's immediate family, or the employee's partner.
 - iii. Any public official, member of the local governing body, or State or local legislator, or any member of such individuals' immediate family, who exercises functions or responsibilities with respect to the project(s) of the PHA. (Note: For additional important provisions see Section 19 of the ACC)



ADDITIONAL CLAUSES AND REQUIREMENTS

Page 17 of 17

- d. No present or former PHA employee, officer, or agent shall engage in selling or attempting to sell supplies, services, or construction to the PHA for one year following the date such employment ceased (see Sections 515 of the old ACC, form HUD-53011, dated 11/69, and Section 19 of the new ACC, form HUD-53012A, dated 7/95). The term "sell" means signing a bid or proposal, negotiating a contract, contacting any PHA employee, officer, or agent for the purpose of obtaining, negotiating, or discussing changes in specifications, price, cost allowances, or other terms of a contract; settling contract disputes; or any other liaison activity with a view toward the ultimate consummation of a sale, although the actual contract is negotiated by another person.



DIVISION 1 DOCUMENTS



ATTACHMENT H

SCOPE OF WORK, SITE VISIT SCHEDULE, SNRHA'S COVID-19 NOTICE TO CONTRACTORS

(In addition to the Technical Specifications as stated within Section 2.13 of this solicitation document)

Appendix 1

SCOPE OF WORK REHABILITATION

802 MCWILLIAMS, LAS VEGAS, NV 89106

Appendix 2

SITE VISIT SCHEDULE

Appendix 3

SNRHA'S COVID-19 NOTICE TO CONTRACTORS



802 McWilliams

SCOPE OF WORK

Provide all necessary labor and material to repair unit for occupancy located at 802 McWilliams

WORK ITEMS

- Competing vendors must inspect the complete area where repairs will be performed. Contractor is requiring to field verify unit size and condition of unit for their bid. Contractor will be responsible for ensuring that this rehabilitation work is constructed under the current ordinances, regulations and codes of the City of Las Vegas and that the proper permits be pulled by the licensed trades.
- Contractor will be responsible for ensuring that City of Las Vegas Damage Assessment Inspection Report MTG # 23-00163 shall be incorporated into Scope of Work as required.

- **Exterior Finishes**

- Repair all damaged exterior finishes. All repairs shall match existing finishes. This includes the replacement of front entry door and the front window. Make all CMU and masonry crack and structural repairs prior to priming and painting of building exterior walls. Exterior paint colors and finishes shall match surrounding surfaces per INNOVA Technologies design of repairs to the damage slump block masonry wall repair.

- **Electrical**

- Repair and/or replace damaged electrical wiring, devices & panels. Correct and/or install wiring to nearest device box to eliminate standalone junction boxes.

- **Interior and Drywall**

- Repair and/or replace damaged drywall throughout unit. Level 3 wall and ceiling finish. Primer and paint interior drywall, doors, and trim. Colors and sheen to be selected by owner and shall include 2 contrasting colors and sheens.



- Provide and install new insulation to meet applicable code. Provide and install acoustical insulation in bathrooms. Ceiling to be a sag resistant gypsum ceiling board. Green board at all other walls at wet area.

- **Exterior Door**

- Install a new fire rated six panel exterior entry door to match existing. Install mail slot on face of exterior door to match existing. Install exterior light fixture which match existing to expose numbered address. Install window and mesh screen to match existing.

- **Interior doors**

- Replace all interior doors with pre-hung six panel doors. Adjust, install and/or replace framing to accommodate new doors. Installation shall also include linen closets, coat closets, and pantry. Door hardware shall be consistent throughout unit. Install new door stops throughout.

- **Closet doors**

- Install closet poles and shelves as needed. Install new closet doors and hardware to match interior swing door selections. Frame closet openings to accommodate standard size closet doors.

- **Flooring**

- Remove existing flooring. Repair and prep subflooring surfaces to receive new flooring as needed, install new owner selected vinyl plank flooring throughout.

- **Baseboards, door casings**

- Install new baseboards, door casings, and trim. Products to be submitted for owner approval prior to installation, baseboards shall be a minimum of 2 ½" in height and shall be similar in profile to casings.

- **Bathroom Hardware**

- Replace tub and shower enclosures and install new fiberglass enclosures Install new bath hardware to include curtains, towel rods, and tissue paper holders.

- **Kitchen and Bath Cabinets**

- Demo and dispose of existing kitchen cabinets and countertops. Remove and replace medicine cabinet. Install new kitchen cabinets & counter tops to match



existing layout. Cabinets shall be solid wood doors and fronts. Counter tops shall be pre-molded plastic laminate. Install new bath vanity cabinets. Submit samples for approval prior to installation. Installation of new sinks shall include all ancillary plumbing items such as lines, drains, pipes, stoppers, & valves. Kitchen sink shall be double bowl stainless steel type. Submit samples for approval prior to install.

- **New energy star appliance package**

- Install new energy star appliance package to include refrigerator, range, range hood, garbage disposal and dishwasher. Refrigerator shall be minimum 21.2 cu ft. Range hoods shall be externally vented. Contractor shall adjust framing, drywall & stucco, and/or roofing to receive vent and accommodate range hood venting as needed.

- **Contractor Responsibility**

- Contractor shall be responsible for all demolition and debris removal to include site cleanup. CLV Damage Assessment Inspection Report shall be incorporated into scope of work as required.
- Contractor shall provide a clean sanitized turn key unit ready for occupancy. Contractor shall be responsible for all demolition and debris removal to include site cleanup.
- Contractor will be required to submit material submittal to the SNRHA for approval. Submittal lead times will be approved during pre-construction. Submittal approval will be required prior to installing the product.
- Contractor shall provide all of the documentation and drawings necessary to acquire a building permit. Contractor shall be responsible for pulling and paying for all building permits and completing work in compliance with building codes including local municipalities.
- Contractor shall provide one (1) year warranty on equipment, parts and labor and submit all manufacturer's warranties.

**802 McWilliams Avenue
Las Vegas, NV**

**Masonry Wall Repair
Structural Calculations**

Prepared For:
Brian Hasemann
SNRHA
340 N 11th Street
Las Vegas, NV 89101

Digitally signed by Adriana
Gonorazky P E S E
DN: C=US,
E=adrianag@innovatv.com,
O=Innova Technologies
Inc., OU=Vice President,
CN=Adriana Gonorazky
P E S E
Location: 1432 South Jones
Blvd., Las Vegas NV 89146
Reason: I have reviewed
this document
Contact Info: 702-220-6640
Date: 2023.09.11
10:41:27-0700



Prepared By:
1432 South Jones Blvd
Las Vegas, NV. 89146
(702) 220-6640



09/11/2023

ITI Project No.: 123-306

REV.	DATE.	BY	CHK:	COMMENTS
0	09/11/2023	SFZ	SEM	ISSUED FOR APPROVAL

Project Index

Drawings	Sheets 1-2
Note to Reviewer	0.2
Design Criteria	0.2 – 0.11
Calculations: Vestibule Building	1.1 – 1.26
Appendix A: Reference Documents	A1 – A24

Note to Reviewer

These calculations are prepared for the design of repairs to the damaged slump block masonry wall located at 802 McWilliams Ave in Las Vegas, NV.

Calculations were performed in US Customary units using the Allowable Stress Design (ASD) and Load and Resistance Factor Design (LRFD) methods according to the *2021 International Building Code* and all associated codes and local amendments.

Design Criteria

- Wind Criteria
 - $V = 98$ mph
 - Exposure Category = C
 - Wall Wind Pressures = 16 psf
 - Roof Wind Pressure = -17 psf
- Seismic Criteria
 - Site Class = D-Default
 - $S_d = 0.53$
 - $S_d1 = 0.33$
 - SDC = D
- Materials
 - 8" thick Medium weight hollow slump block (to match existing)
 - Fully grouted
 - $f'_m = 1500$ psi

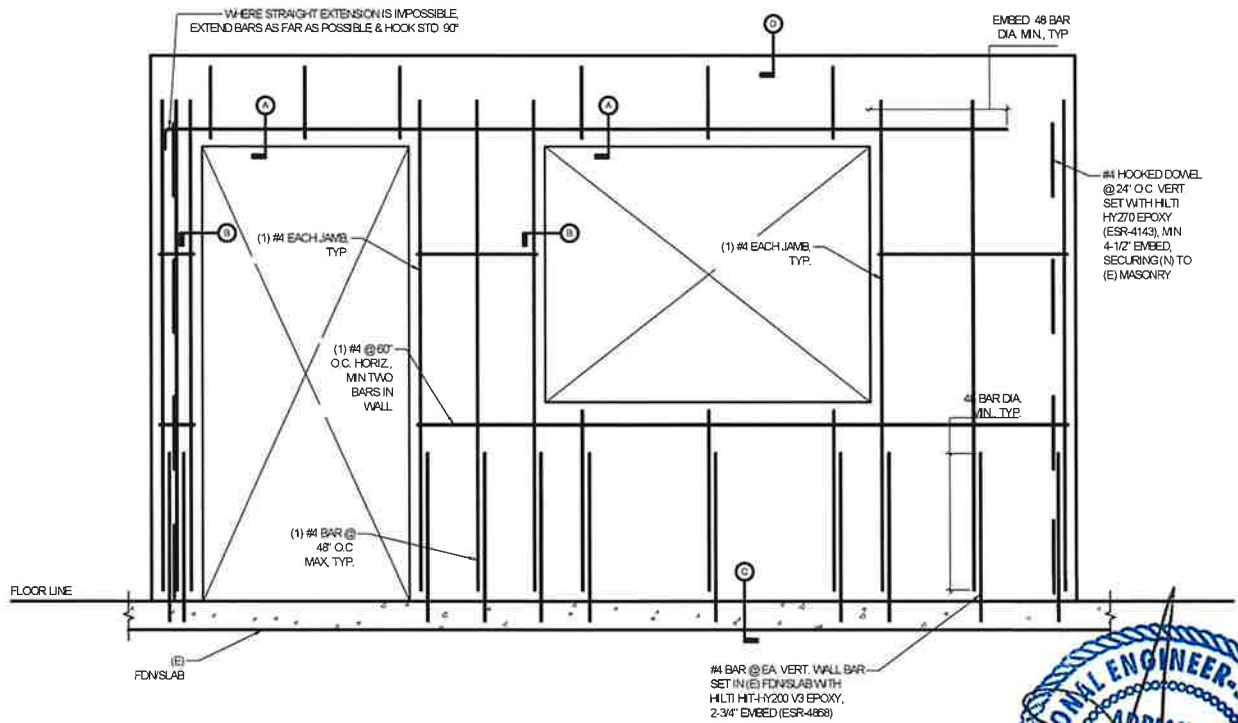
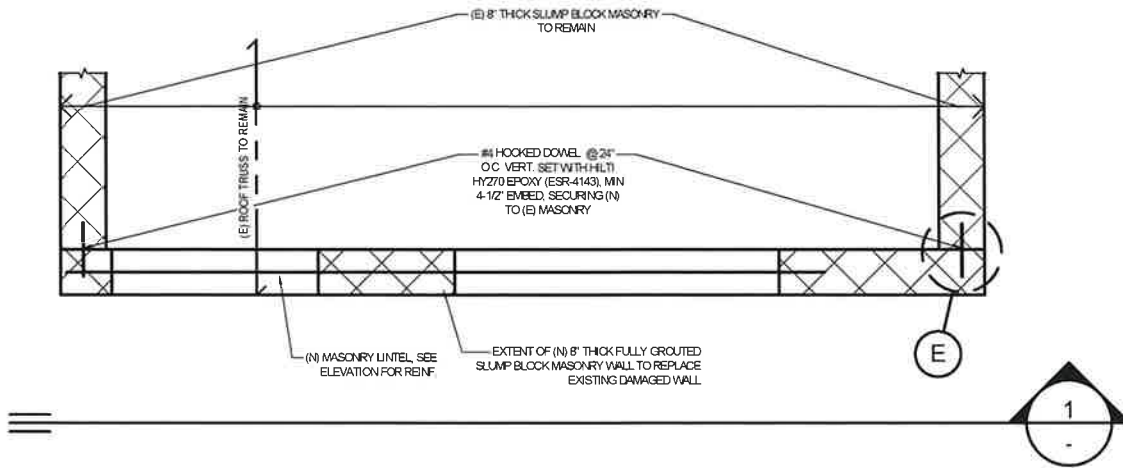

1 CMU WALL REPAIR ELEVATION

SCALE: N.T.S.

NOTE: (N) BLOCK TO BE MEDIUM WEIGHT (f_m = 1500PSI)
SLUMP BLOCK TO MATCH EXISTING.



09/11/2023



INNOVATING SOLUTIONS
FOR YOU 2
1432 S. JONES BLVD.
LAS VEGAS, NV
89146
TEL: 702.220.6640
FAX: 702.220.7740
WWW.INNOVANV.COM

WALL REPAIR PARTIAL PLAN & ELEVATION

SNRHA MASONRY WALL REPAIR
802 McWILLIAMS AVE
LAS VEGAS, NV 89106

Proj No:	123-306
Design	SFZ
Drawn	SFZ
Checked	SEM
Issue Date	09-08-2023
Sheet	1 OF 2

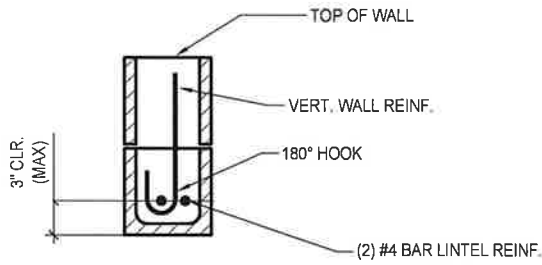

A LINTEL AND TOP OF WALL

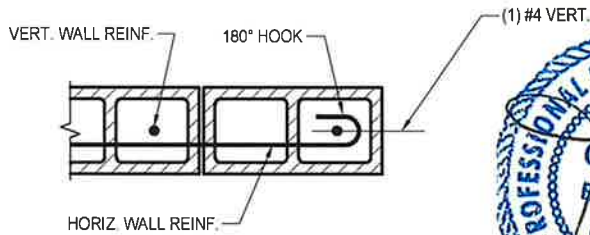

B JAMB OR END OF WALL



09/11/2023

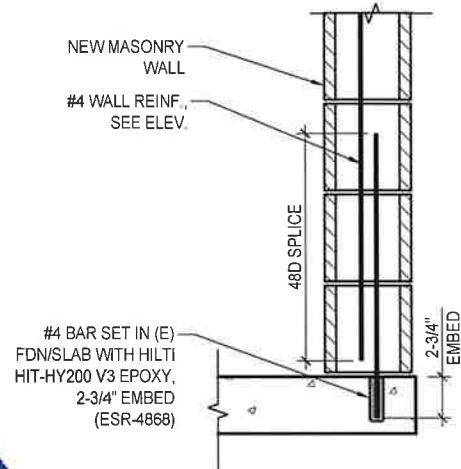

C (N) WALL TO (E) FDN/SLAB

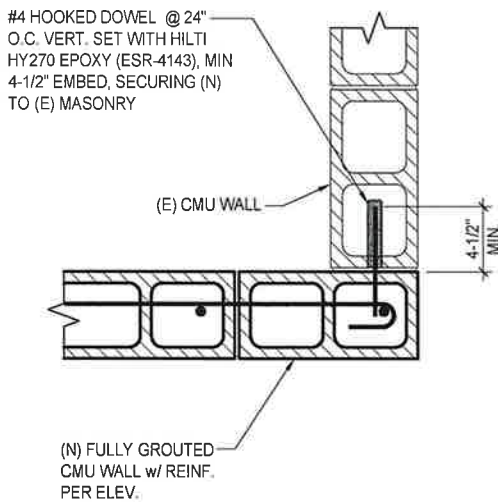

E (N) TO (E) WALL CONX

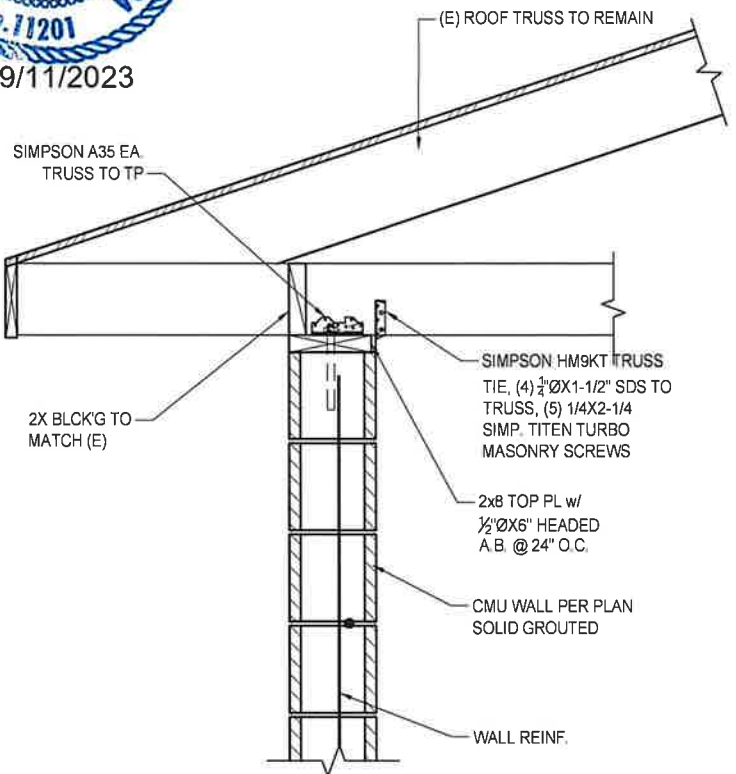

D (E) TRUSS TO (N) WALL



INNOVATING SOLUTIONS FOR YOU

1432 S. JONES BLVD.
 LAS VEGAS, NV 89146

TEL: 702.250.6640
 FAX: 702.250.7740
 WWW.INNOVAVN.COM

WALL REPAIR DETAILS

SNRHA MASONRY WALL REPAIR
 802 McWILLIAMS AVE
 LAS VEGAS, NV 89106

Proj No	123-306
Design	SFZ
Drawn	SFZ
Checked	SEM
Issue Date	09-08-2023
Sheet	2 OF 2



ASCE 7 Hazards Report

Address:
802 W McWilliams Ave
Las Vegas, Nevada
89106

Standard: ASCE/SEI 7-22
Risk Category: II
Soil Class: Default

Latitude: 36.179273
Longitude: -115.151972
Elevation: 2035.5757916640137 ft
(NAVD 88)

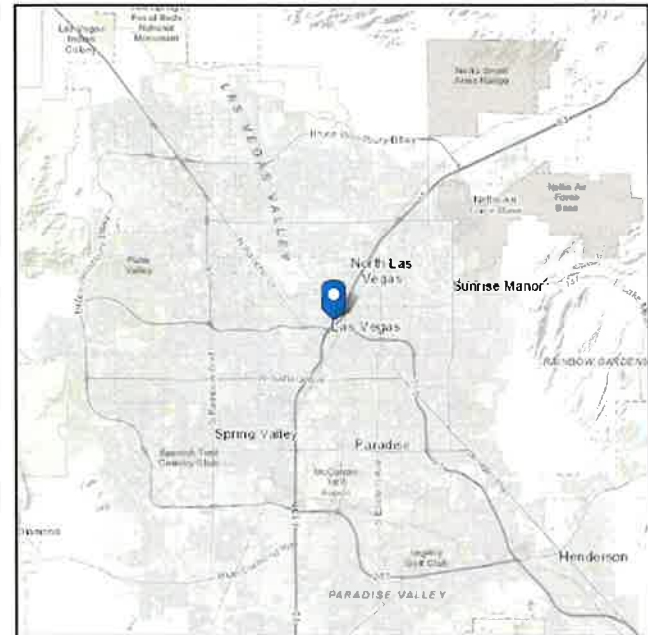
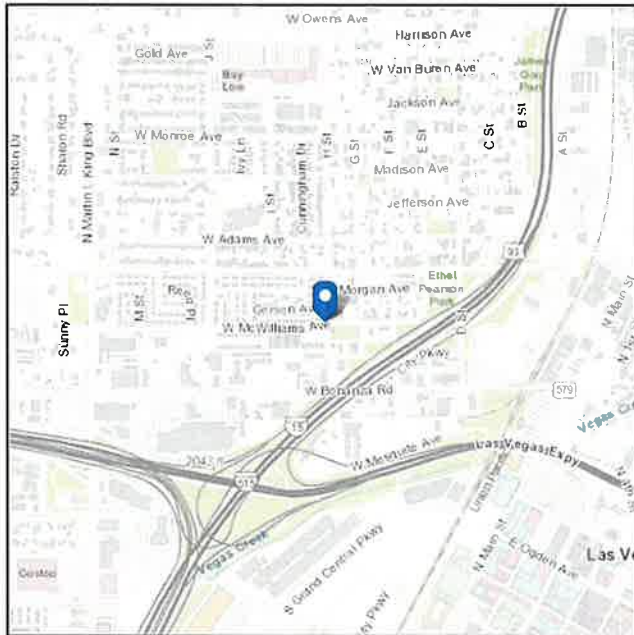

Wind

Results:

Wind Speed	98 Vmph
10-year MRI	69 Vmph
25-year MRI	75 Vmph
50-year MRI	80 Vmph
100-year MRI	85 Vmph
300-year MRI	92 Vmph
700-year MRI	98 Vmph
1,700-year MRI	105 Vmph
3,000-year MRI	109 Vmph
10,000-year MRI	118 Vmph
100,000-year MRI	135 Vmph
1,000,000-year MRI	153 Vmph

Data Source: ASCE/SEI 7-22, Fig. 26.5-1B and Figs. CC.2-1–CC.2-4, and Section 26.5.2
Date Accessed: Thu Sep 07 2023



Value provided is 3-second gust wind speeds at 33 ft above ground for Exposure C Category, based on linear interpolation between contours. Wind speeds are interpolated in accordance with the 7-22 Standard. Wind speeds correspond to approximately a 7% probability of exceedance in 50 years (annual exceedance probability = 0.00143, MRI = 700 years). Values for 10-year MRI, 25-year MRI, 50-year MRI and 100-year MRI are Service Level wind speeds, all other wind speeds are Ultimate wind speeds.

Site is not in a hurricane-prone region as defined in ASCE/SEI 7-22 Section 26.2.

Site Soil Class:

Results:

PGA _M :	0.32	T _L :	6
S _{MS} :	0.79	S _S :	0.66
S _{M1} :	0.49	S ₁ :	0.19
S _{DS} :	0.53	V _{S30} :	260
S _{D1} :	0.33		

Seismic Design Category: D

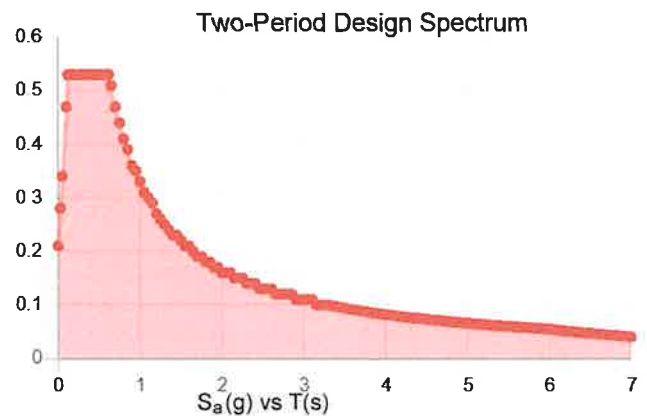
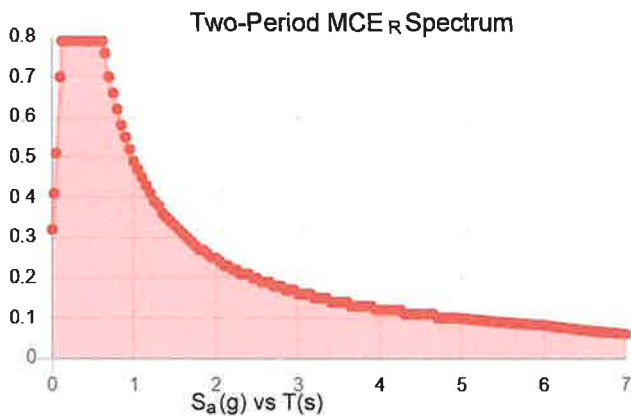
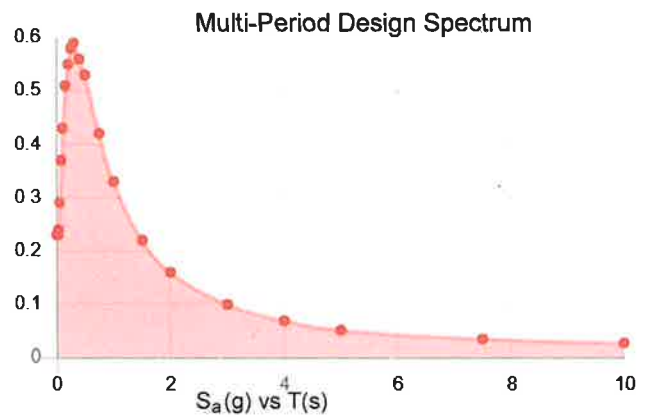
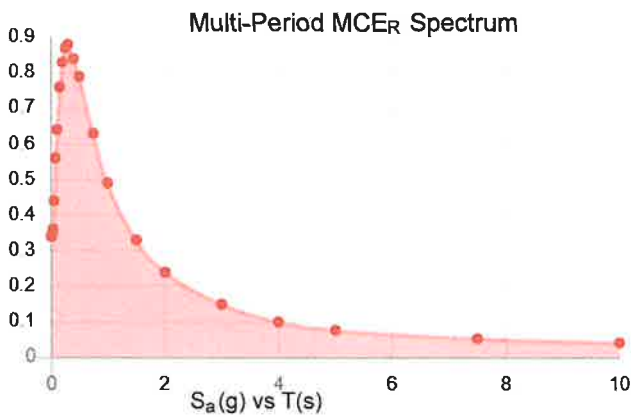

MCE_R Vertical Response Spectrum

Vertical ground motion data has not yet been made available by USGS.

Design Vertical Response Spectrum

Vertical ground motion data has not yet been made available by USGS.



Data Accessed: Thu Sep 07 2023

Date Source:

USGS Seismic Design Maps based on ASCE/SEI 7-22 and ASCE/SEI 7-22 Table 1.5-2. Additional data for site-specific ground motion procedures in accordance with ASCE/SEI 7-22 Ch. 21 are available from USGS.

Results:

Ground Snow Load, p_g :	9 lb/ft ²
Allowable Stress Design Ground Snow Load:	6.3 lb/ft ²
20-year MRI Value:	1.28 lb/ft ²
Winter Wind Parameter:	0.35
Mapped Elevation:	2003.0 ft
Data Source:	ASCE/SEI 7-22, Figures 7.6-1 and 7.6-2 A-D
Date Accessed:	Thu Sep 07 2023

Values provided are ground snow loads. In areas designated "case study required," extreme local variations in ground snow loads preclude mapping at this scale. Site-specific case studies are required to establish ground snow loads at elevations not covered.

Snow load values are mapped to a 0.5 mile resolution. This resolution can create a mismatch between the mapped elevation and the site-specific elevation in topographically complex areas. Engineers should consult the local authority having jurisdiction in locations where the reported 'elevation' and 'mapped elevation' differ significantly from each other.

The ASCE 7 Hazard Tool is provided for your convenience, for informational purposes only, and is provided "as is" and without warranties of any kind. The location data included herein has been obtained from information developed, produced, and maintained by third party providers; or has been extrapolated from maps incorporated in the ASCE 7 standard. While ASCE has made every effort to use data obtained from reliable sources or methodologies, ASCE does not make any representations or warranties as to the accuracy, completeness, reliability, currency, or quality of any data provided herein. Any third-party links provided by this Tool should not be construed as an endorsement, affiliation, relationship, or sponsorship of such third-party content by or from ASCE.

ASCE does not intend, nor should anyone interpret, the results provided by this Tool to replace the sound judgment of a competent professional, having knowledge and experience in the appropriate field(s) of practice, nor to substitute for the standard of care required of such professionals in interpreting and applying the contents of this Tool or the ASCE 7 standard.

In using this Tool, you expressly assume all risks associated with your use. Under no circumstances shall ASCE or its officers, directors, employees, members, affiliates, or agents be liable to you or any other person for any direct, indirect, special, incidental, or consequential damages arising from or related to your use of, or reliance on, the Tool or any information obtained therein. To the fullest extent permitted by law, you agree to release and hold harmless ASCE from any and all liability of any nature arising out of or resulting from any use of data provided by the ASCE 7 Hazard Tool.

MecaWind v2428

Developed by Meca Enterprises Inc., www.mecaenterprises.com, Copyright © 2023

Calculations Prepared by:

Date: Sep 07, 2023

File Location: Current Project Not Saved

General:

Wind Load Standard	= ASCE 7-22	Basic Wind Speed	= 98.0 mph
Exposure Classification	= C	Risk Category	= II
Structure Type	= Building	Design Basis for Wind Pressures	= LRFD
MWFRS Analysis Method	= Ch 27	C&C Analysis Method	= None
Dynamic Type of Structure	= Rigid	Show Advanced Options	= False

Building:

Roof	= Roof Type	= Gabled	Encl	= Enclosure Classification	= Enclosed
Help	= Help on Building Roof Type	= Help	Pitch	= Pitch of Roof	= 2.12 :12
θ	= Slope of Roof	= 10.0 Deg	R_{Ht}	= Ridge Height	= 12.028 ft
E_{Ht}	= Eave Height	= 10.000 ft	W	= Building Width	= 23.000 ft
L	= Building Length	= 56.000 ft	OH	= Type of Overhang	= Custom
Par	= Parapet Porosity	= None	HT_{over}	= Override Mean Roof Height	= False
Ht_{man}	= Mean Roof Height	= 10.000 ft	RA_{over}	= Override Roof Area	= False
IsElev	= Building is Elevated	= False			

Exposure Constants [Table 26.11-1]:

α = 3-s Gust-speed exponent	= 9.800	Z_g = Nominal Ht of Boundary Layer	= 2460.000 ft
$\hat{\alpha}$ = Recipicol of α	= 0.102 ft	b = 3 sec gust speed factor	= 1.000
α_m = Mean hourly Wind-Speed Exponent	= 0.156	b_m = Mean hourly Windspeed Exponent	= 0.660
c = Turbulence Intensity Factor	= 0.200	ϵ = Integral Length Scale Exponent	= 0.2000

Main Wind Force Resisting System (MWFRS) Wind Calculations per Ch 27

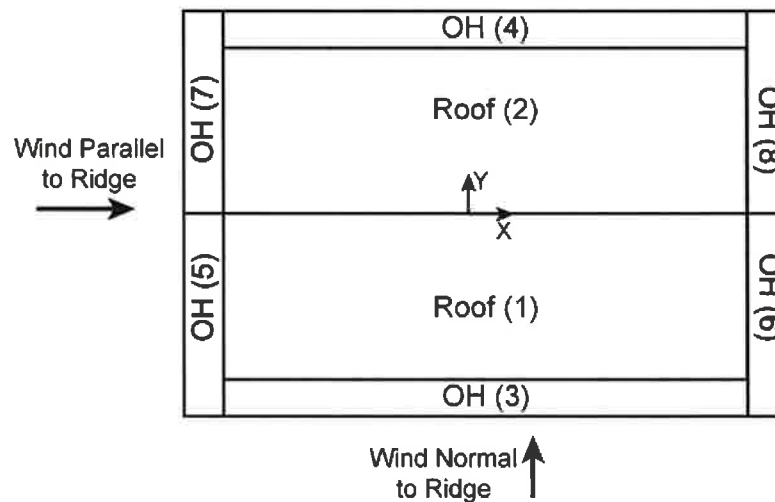

h	= Mean structure height	= 10.000 ft
K_z	= $2.41 \cdot (15/Z_g)^{2/\alpha}$ [Table 26.10-1]	= 0.851
K_{zt}	= No Topographic feature specified	= 1.000
K_d	= Wind Directionality Factor per Table 26.6-1	= 0.85
+ GC_{pi}	= Enclosed Positive Internal Pressure Table 26.13-1	= +0.18
- GC_{pi}	= Enclosed Negative Internal Pressure Table 26.13-1	= -0.18
LF	= Load Factor based upon STRENGTH Design	= 1.00
q_h	= $0.00256 \cdot K_h \cdot K_{zt} \cdot K_e \cdot V^2 \cdot LF$ [Eqn 26.10-1]	= 20.93 psf
K_e	= Ground Elevation Factor: $e^{-0.0000362 \cdot Z_g}$ [Table 26.10-1]	= 1.000
RA	= Roof Area	= 1472.37 ft ²
q_h	= $0.00256 \cdot K_h \cdot K_{zt} \cdot K_e \cdot V^2 \cdot LF$ [Eqn 26.10-1]	= 20.93 psf

q_{in} = Negative Internal Pressure: q_h•LF = 20.93 psf
 q_{ip} = Positive Internal Pressure: q_h•LF = 20.93 psf

MWFRS Wind Loads [Normal to Ridge]

h = Mean Roof Height Of Building = 10.000 ft
 RHt = Ridge Height Of Roof = 12.028 ft
 B = Horizontal Dimension Of Building Normal To Wind Direction = 56.000 ft
 L = Horizontal Dimension Of building Parallel To Wind Direction = 23.000 ft
 L/B = Ratio Of L/B used For Cp determination = 0.411
 h/L = Ratio Of h/L used For Cp determination = 0.435
 Slope = Slope Of Roof = 10.0 Deg

Gust Factor Calculation for Wind: [Normal to Ridge]

Gust Factor Category I Rigid Structures - Simplified Method

G₁ = For Rigid Structures (Natural Frequency > 1 Hz) use 0.85 = 0.85

Gust Factor Category II Rigid Structures - Complete Analysis

Z_m = Equiv Height of Struc: Max(0.6•Ht, Z_{min}) = 15.000 ft

I_{zm} = Intensity of Turbulence at height Z_m: c•(33/Z_m)^{1/6} [Eqn 26.11-7] = 0.228

L_{zm} = Integral Length Scale of Turbulence [Eqn 26.11-9] = 427.057 ft

B = Building Width Width Normal to Wind Direction = 56.000 ft

Q = 1/(1+0.63•[(B+Ht)/L_{zm}]^{0.63}) [Eqn 26.11-8] = 0.915

G₂ = 0.925•((1+1.7•3.4•I_{zm}•Q)/(1+1.7•3.4•I_{zm})) = 0.880

Gust Factor Used in Analysis

G = Gust Factor: Min(G₁, G₂) = 0.850

C_{PWW} = Windward Wall Coefficient (All L/B Values) = 0.800

C_{PLW} = Leeward Wall Coefficient using L/B = -0.500

C_{PSW} = Side Wall Coefficient (All L/B values) = -0.700

Wind Pressures [Normal to Ridge]
 All wind pressures include a Load Factor (LF) of 1.0

Elev	GC _{pi}	q _i	K _z	K _{zt}	q _z	Windward Press	Leeward Press	Side Press	Total Press	Minimum Pressure*
ft		psf			psf	psf	psf	psf	psf	psf
10.000	+0.18	20.93	0.851	1.000	20.93	8.89	-10.76	-13.79	19.66	16.00
10.000	-0.18	20.93	0.851	1.000	20.93	15.30	-4.36	-7.38	19.66	16.00

Notes Wall Pressures

K_z = 2.41•(15/Z_g)^{2/α} | K_{zt} = No Topographic feature specified
 GC_{pi} = Enclosed Internal Pressure Table 26.13-1 | q_z = 0.00256•K_z•K_{zt}•K_e•V²•LF [Eqn 26.10-1]
 q_{ip} = Positive Internal Pressure: q_h•LF | q_{in} = Negative Internal Pressure: q_h•LF
 Side = q_h•K_d•G•C_{PSW}-q_{ip}•K_d•(+GC_{pi}) Eqn 27.3-1 | Leeward = q_h•K_d•G•C_{PLW}-q_{ip}•K_d•(+GC_{pi}) Eqn 27.3-1
 Windward = q_z•K_d•G•C_{PWW}-q_{ip}•K_d•(+GC_{pi}) Eqn 27.3-1 | Total = Windward - Leeward
 • Minimum Pressure: Para 27.1.5 no less than 16.00 psf (Incl LF) applied to Walls
 • Positive Pressures Act TOWARD Surface and Negative Pressures Act AWAY from Surface

Roof Wind Pressures for Positive & Negative Internal Pressure (±GC_{pi}) [Normal to Ridge]
 All wind pressures include a Load Factor (LF) of 1.0

Reference	Description	Location	C _p Min	C _p Max	GC _{pi}	Pressure Min psf	Pressure Max psf
Roof	Roof Windward 1		-0.180	-0.848	+0.18/-0.18	-16.02	0.48
Roof	Roof Leeward 2		-0.448	-0.448	+0.18/-0.18	-9.97	-3.57

Notes Roof Pressures based upon Ch 27:

Start = Start Dist from Windward Edge | End = End Dist from Windward Edge
 C_{p_min} = Smallest Coefficient Magnitude | C_{p_max} = Largest Coefficient Magnitude
 Press_{Min} = q_h•K_d•G•C_{p_min}-q_{ip}•K_d•(+GC_{pi}) Eqn 27.3-1 | Press_{Max} = q_h•K_d•G•C_{p_max}-q_{in}•K_d•(-GC_{pi}) Eqn 27.3-1
 • No reduction factor was applicable

- The smaller uplift pressures due to Cp_Min can become critical when wind is combined with roof live load or snow load; load combinations are given in ASCE 7
- Positive Pressures Act TOWARD Surface and Negative Pressures Act AWAY from Surface

MWFRS Wind Loads [Parallel to Ridge]

h	= Mean Roof Height Of Building	= 10.000 ft
RHt	= Ridge Height Of Roof	= 12.028 ft
B	= Horizontal Dimension Of Building Normal To Wind Direction	= 23.000 ft
L	= Horizontal Dimension Of building Parallel To Wind Direction	= 56.000 ft
L/B	= Ratio Of L/B used For Cp determination	= 2.435
h/L	= Ratio Of h/L used For Cp determination	= 0.179
Slope	= Slope Of Roof	= 10.0 Deg

Gust Factor Calculation for Wind: [Parallel to Ridge]

Gust Factor Category I Rigid Structures - Simplified Method

G ₁	= For Rigid Structures (Natural Frequency > 1 Hz) use 0.85	= 0.85
----------------	--	--------

Gust Factor Category II Rigid Structures - Complete Analysis

Z _m	= Equiv Height of Struc: Max(0.6*Ht, Z _{min})	= 15.000 ft
I _{z_m}	= Intensity of Turbulence at height Z _m : c*(33/Z _m) ^{1/6} [Eqn 26.11-7]	= 0.228
L _{z_m}	= Integral Length Scale of Turbulence [Eqn 26.11-9]	= 427.057 ft
B	= Building Width Width Normal to Wind Direction	= 23.000 ft
Q	= 1/(1+0.63*[(B+Ht)/L _{z_m}] ^{0.63}) [Eqn 26.11-8]	= 0.943
G ₂	= 0.925*((1+1.7*3.4*I _{z_m} *Q)/(1+1.7*3.4*I _{z_m}))	= 0.895

Gust Factor Used in Analysis

G	= Gust Factor: Min(G ₁ , G ₂)	= 0.850
---	--	---------

Cp _{WW}	= Windward Wall Coefficient (All L/B Values)	= 0.800
Cp _{LW}	= Leeward Wall Coefficient using L/B	= -0.278
Cp _{SW}	= Side Wall Coefficient (All L/B values)	= -0.700

**Wind Pressures [Parallel to Ridge]
All wind pressures include a Load Factor (LF) of 1.0**

Elev ft	GC _{pi}	q _i psf	K _z	K _{zt}	q _z psf	Windward Press psf	Leeward Press psf	Side Press psf	Total Press psf	Minimum Pressure* psf
12.028	+0.18	20.93	0.851	1.000	20.93	8.89	-7.41	-13.79	16.30	16.00
10.000	+0.18	20.93	0.851	1.000	20.93	8.89	-7.41	-13.79	16.30	16.00
12.028	-0.18	20.93	0.851	1.000	20.93	15.30	-1.01	-7.38	16.30	16.00
10.000	-0.18	20.93	0.851	1.000	20.93	15.30	-1.01	-7.38	16.30	16.00

Notes Wall Pressures

K _z	= 2.41*(15/Z _g) ^{2/α}	K _{zt}	= No Topographic feature specified
GC _{pi}	= Enclosed Internal Pressure Table 26.13-1	q _z	= 0.00256*K _z *K _{zt} *K _e *V ² *LF [Eqn 26.10-1]
q _{ip}	= Positive Internal Pressure: q _h *LF	q _{in}	= Negative Internal Pressure: q _h *LF
Side	= q _h *K _d *G*Cp _{SW} -q _{ip} *K _d *(+GC _{pi}) Eqn 27.3-1	Leeward	= q _h *K _d *G*Cp _{LW} -q _{ip} *K _d *(+GC _{pi}) Eqn 27.3-1
Windward	= q _z *K _d *G*Cp _{WW} -q _{ip} *K _d *(+GC _{pi}) Eqn 27.3-1	Total	= Windward - Leeward

- Minimum Pressure: Para 27.1.5 no less than 16.00 psf (Incl LF) applied to Walls
- Positive Pressures Act TOWARD Surface and Negative Pressures Act AWAY from Surface

**Roof Wind Pressures for Positive & Negative Internal Pressure (±GC_{pi}) [Parallel to Ridge]
All wind pressures include a Load Factor (LF) of 1.0**

Reference	Description	Location	Start Dist ft	End Dist ft	C _p Min	C _p Max	GC _{pi}	Pressure Min psf	Pressure Max psf
OH_Top	Overhang Top (0 to h)	3,4,5,7	0.000	10.000	-0.900	-0.180	+0.00/-0.00	-13.61	-2.72
OH_Top	Overhang Top (h to 2*h)	3,4	10.000	20.000	-0.500	-0.180	+0.00/-0.00	-7.56	-2.72
OH_Top	Overhang Top (>= 2*h)	3,4,6,8	20.000	57.000	-0.300	-0.180	+0.00/-0.00	-4.54	-2.72
Roof	Roof (0 to h)	1,2	0.000	10.000	-0.900	-0.180	+0.18/-0.18	-16.81	0.48
Roof	Roof (h to 2*h)	1,2	10.000	20.000	-0.500	-0.180	+0.18/-0.18	-10.76	0.48

Roof Roof ($\geq 2 \cdot h$) 1,2 20.000 56.000 -0.300 -0.180 +0.18/-0.18 -7.74 0.48

Notes Roof Pressures based upon Ch 27:

Start = Start Dist from Windward Edge

C_{p_min} = Smallest Coefficient Magnitude

$Press_{Min} = q_h \cdot K_d \cdot G \cdot C_{p_min} - q_{ip} \cdot K_d \cdot (+GC_{pi})$ Eqn 27.3-1

End = End Dist from Windward Edge

C_{p_max} = Largest Coefficient Magnitude

$Press_{Max} = q_h \cdot K_d \cdot G \cdot C_{p_max} - q_{in} \cdot K_d \cdot (-GC_{pi})$ Eqn 27.3-1

- No reduction factor was applicable
- The smaller uplift pressures due to C_{p_min} can become critical when wind is combined with roof live load or snow load; load combinations are given in ASCE 7
- Positive Pressures Act TOWARD Surface and Negative Pressures Act AWAY from Surface

Calculations

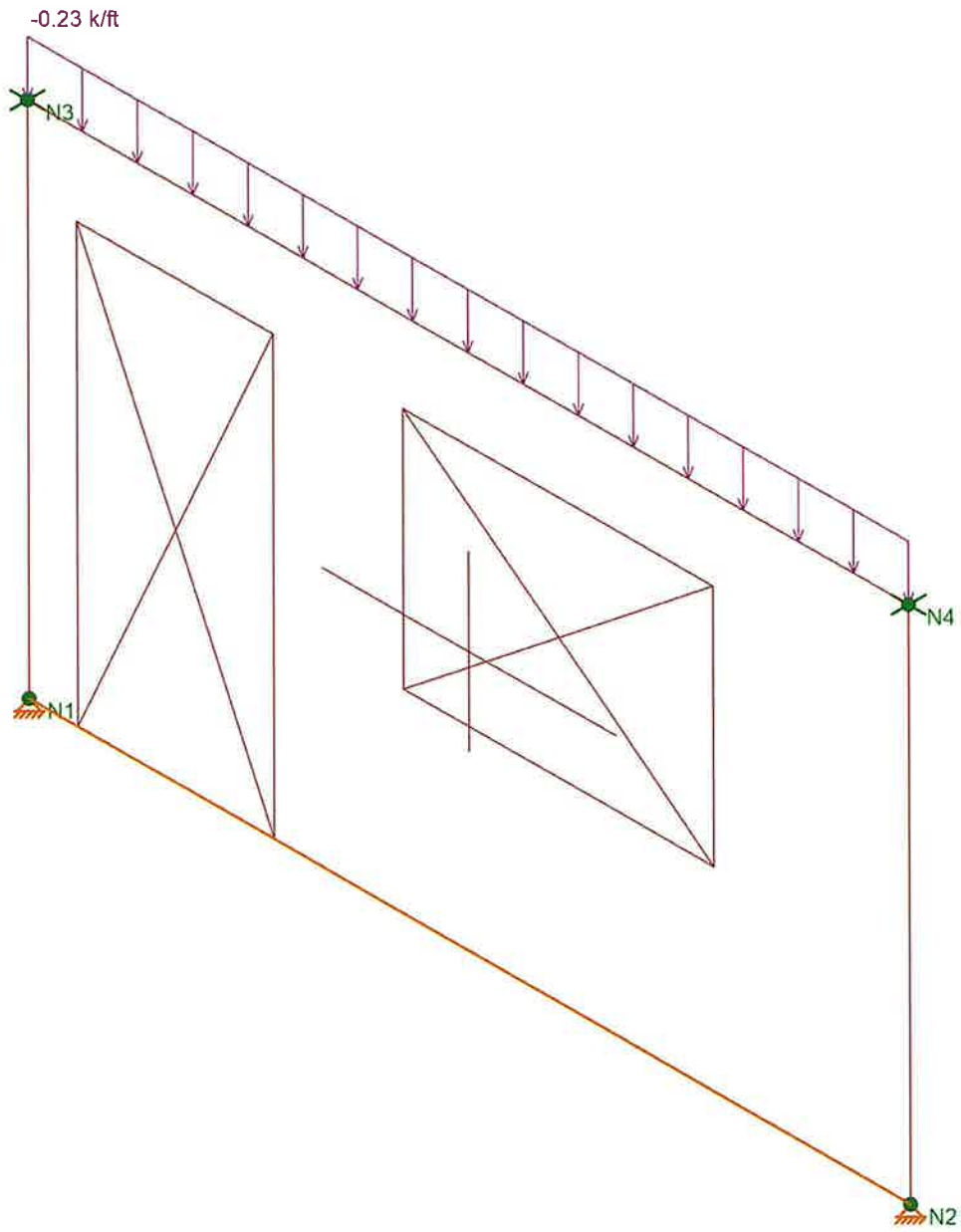
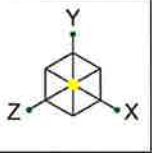

Loads: BLC 1, DL
Envelope Only Solution



<Licensed Company>
szeidman

SK-1
Sep 08, 2023 at 01:45 PM
wall panel.r3d

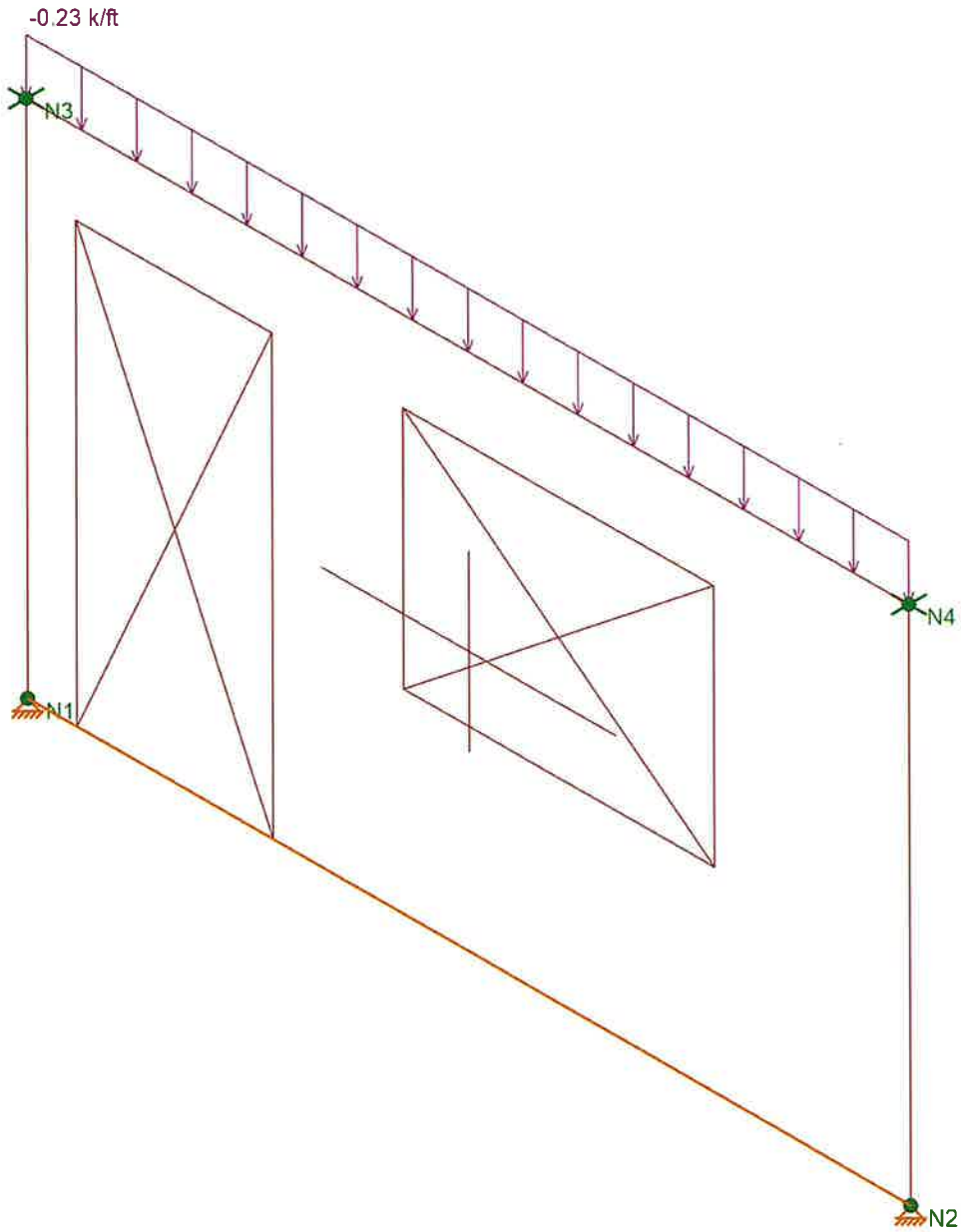
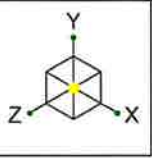

Loads: BLC 2, LLr
Envelope Only Solution



<Licensed Company>
szejman

SK-2
Sep 08, 2023 at 01:45 PM

wall panel.r3d

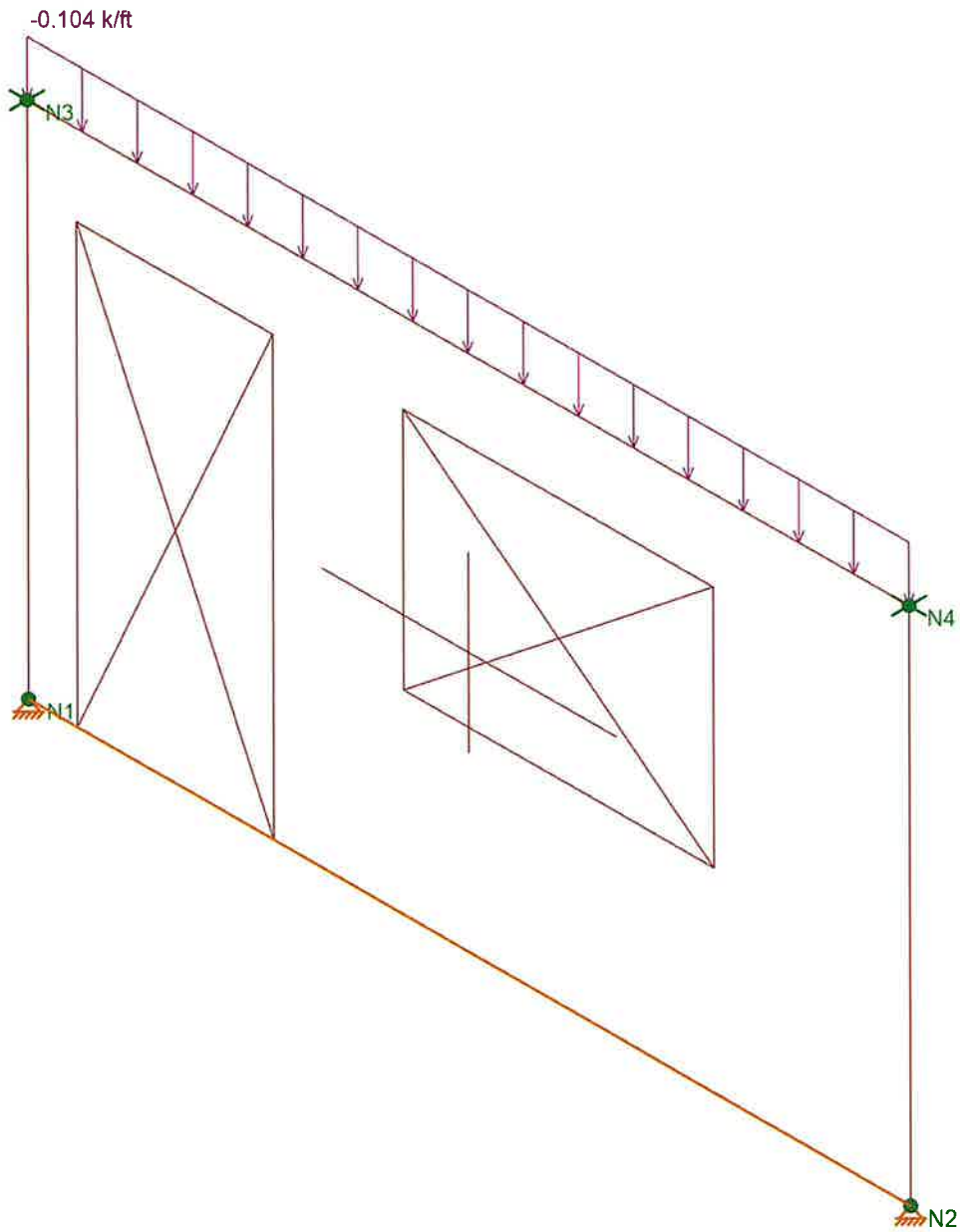
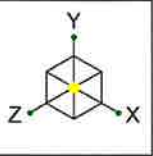

Loads: BLC 3, SL
Envelope Only Solution



<Licensed Company>
szeidman

SK-3
Sep 08, 2023 at 01:45 PM

wall panel.r3d

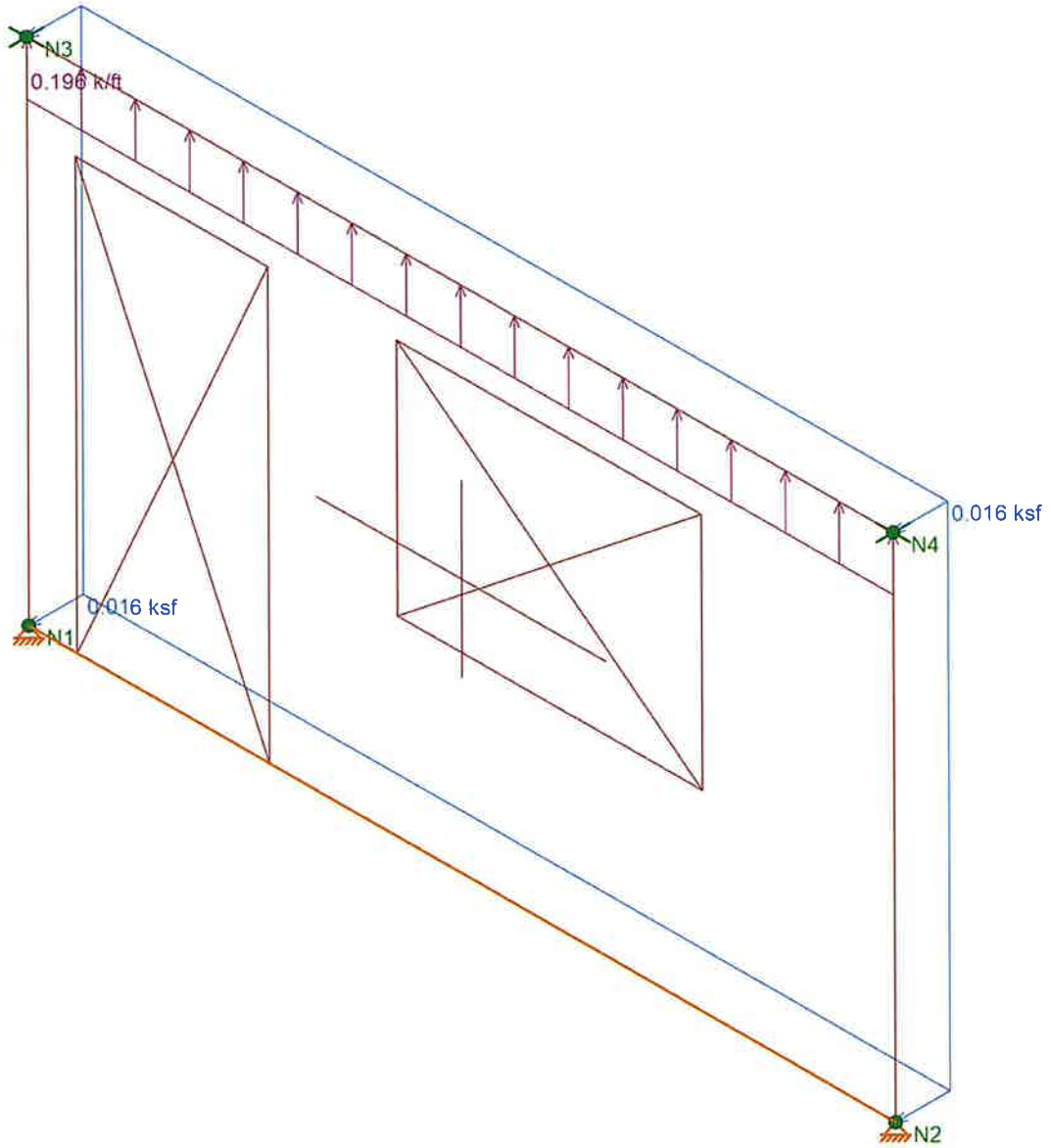
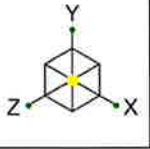

Loads: BLC 6, W
Envelope Only Solution



<Licensed Company>
szeidman

SK-4
Sep 08, 2023 at 01:46 PM
wall panel.r3d

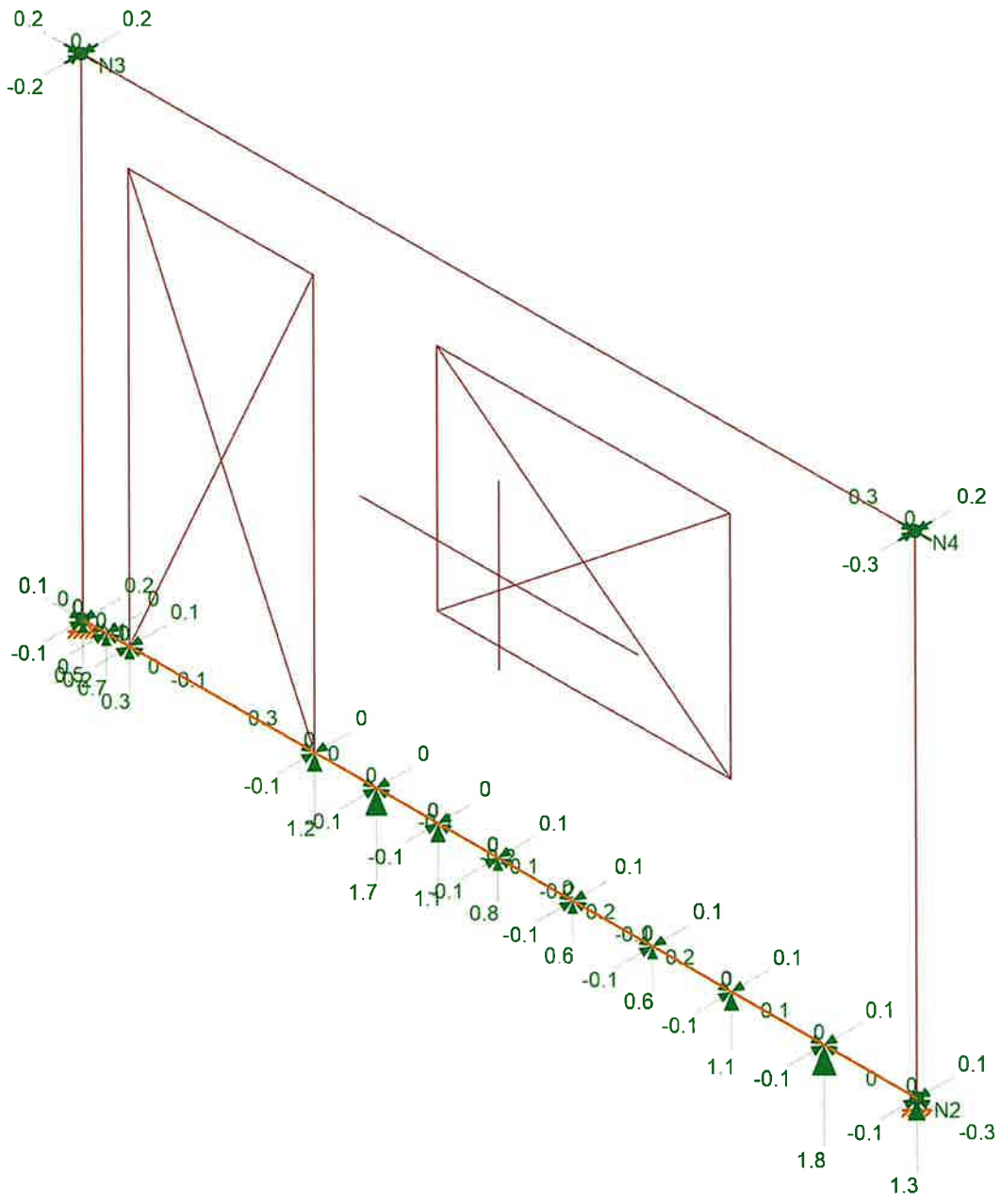
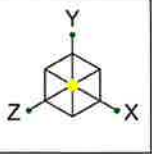

Envelope Only Solution
 Reaction and Moment Units are kips and kip-ft (Enveloped)



<Licensed Company>
 szejidman

SK-5
 Sep 08, 2023 at 01:46 PM
 wall panel.r3d

Node Coordinates

	Label	X [ft]	Y [ft]	Z [ft]	Detach From Diaphragm
1	N1	0	0	0	
2	N2	13.5	0	0	
3	N3	0	8	0	
4	N4	13.5	8	0	

Node Boundary Conditions

	Node Label	X [k/in]	Y [k/in]	Z [k/in]
1	N4	Reaction		Reaction
2	N3	Reaction		Reaction
3	N1	Reaction	Reaction	Reaction
4	N2	Reaction	Reaction	Reaction

Masonry Properties

	Label	E [ksi]	G [ksi]	Nu	Therm. Coeff. [$1e^{-6}F^{-1}$]	Self Weight [k/ft ³]	f _m [ksi]	Flex Steel [ksi]	Shear Steel [ksi]
1	Concrete Matl	1350	540	0.25	0.6	Custom	1.5	60	60
2	Clay Matl	1050	420	0.25	0.6	Custom	1.5	60	60
3	Gen Masonry	1050	420	0.25	0.6	0.08	1.5	60	60

Wall Panel Data

	Label	A Node	B Node	C Node	D Node	Material Type	Material Set	Thickness [in]	Design Rule	Panel/Spacing
1	WP1	N1	N3	N4	N2	Masonry	Concrete Matl	8	Typical	48

Wall Panel Advanced Data

	Label	Seismic Rule	Design Method	SSAF	Cm In-Plane	Cm Out-Plane	Stud Bracing	Sheathing	Connect Dist [in]
1	WP1	Ordinary	N/A	N/A	N/A	N/A	N/A		N/A

Wall Panel U.C. Parameters

	Label	Max Bending Chk	Max Shear Chk
1	Typical	1	1

Masonry Wall Panel Parameters

	Label	Block Nom Width	Block Grouting	Reinforced	Wall Area Method
1	Typical	8"	Fully Grouted	Yes	NCMA

Masonry Wall Panel In-Plane Parameters

	Label	Vert Bar Size	Bars Per Cell	Min Bound Zone Width [in]	Max Bound Zone Width [in]	Horz Bar Size	Transfer Load
1	Typical	#4	1	8	48	#4	Yes

Masonry Wall Panel Out-of-Plane Parameters

	Label	Bar Size	Bar Space Min	Bar Space Max	Bar Placement	Cover [in]	Mortar Type	Cement Type	Transfer Load
1	Typical	#4	8"	48"	Center	Min	Type M or S	Portland, Lime/Mortar	Yes

Masonry Wall Panel Lintel Parameters

	Label	Depth [in]	Bear Length [in]	Bar Size	Min # Bars	Per Layer	Max # Bars	Per Layer	Num of Layers	c/c Sp of Layers [in]	Dist To Bot [in]	Stirrup Size	Analysis Method
1	Typical	12	8	#4	1		2		1	N/A	3	#4	Simply Supported



Company : <Licensed Company>
 Designer : szejzman
 Job Number :
 Model Name :

1.8
 9/8/2023
 1:44:07 PM
 Checked By : _____

Masonry Wall Seismic Design Rule

	Label	Wall Types	Special Boundary Elements	1.5x Shear ASD
1	Ordinary	Ordinary		
2	Intermediate	Intermediate		
3	Special	Special	Yes	Yes

Wall Panel Distributed Loads (BLC 1 : DL)

	Wall Label	Direction	Start Magnitude [k/ft, F]	End Magnitude [k/ft, F]	Start Location [(ft, %)]	End Location [(ft, %)]
1	WP1(8ft)	Y	-0.23	-0.23	0	13.5

Wall Panel Distributed Loads (BLC 2 : LLr)

	Wall Label	Direction	Start Magnitude [k/ft, F]	End Magnitude [k/ft, F]	Start Location [(ft, %)]	End Location [(ft, %)]
1	WP1(8ft)	Y	-0.23	-0.23	0	13.5

Wall Panel Distributed Loads (BLC 3 : SL)

	Wall Label	Direction	Start Magnitude [k/ft, F]	End Magnitude [k/ft, F]	Start Location [(ft, %)]	End Location [(ft, %)]
1	WP1(8ft)	Y	-0.104	-0.104	0	13.5

Wall Panel Distributed Loads (BLC 6 : W)

	Wall Label	Direction	Start Magnitude [k/ft, F]	End Magnitude [k/ft, F]	Start Location [(ft, %)]	End Location [(ft, %)]
1	WP1(8ft)	Y	0.196	0.196	0	13.5

Wall Panel Surface Loads (BLC 6 : W)

	Wall Panel Label	Direction	Top Magnitude [ksf, F]	Bottom Magnitude [ksf, F]	Start Location [ft]	Height [ft]
1	WP1	Z	0.016	0.016	0	0

Load Combinations

	Description	Solve	P-Delta	BLC	Factor	BLC	Factor	BLC	Factor	BLC	Factor	BLC	Factor	BLC	Factor	BLC	Factor
1	Deflection 1	Yes	Y	DL	1												
2	Deflection 2	Yes	Y	LL	1												
3	Deflection 3	Yes	Y	DL	1	LL	1										
4	IBC 21/ASCE ASD 1	Yes		DL	1												
5	IBC 21/ASCE ASD 2	Yes		DL	1	LL	1	LLS	1								
6	IBC 21/ASCE ASD 3 (a)	Yes		DL	1	RLL	1										
7	IBC 21/ASCE ASD 3 (b)	Yes		DL	1	SL	1	SLN	1								
8	IBC 21/ASCE ASD 4 (a)	Yes		DL	1	LL	0.75	LLS	0.75	RLL	0.75						
9	IBC 21/ASCE ASD 4 (b)	Yes		DL	1	LL	0.75	LLS	0.75	SL	0.75	SLN	0.75				
10	IBC 21/ASCE ASD 5 (a)	Yes		DL	1	WL	0.6										
11	IBC 21/ASCE ASD 6 (a)	Yes		DL	1	WL	0.45	LL	0.75	LLS	0.75	RLL	0.75				
12	IBC 21/ASCE ASD 6 (b)	Yes		DL	1	WL	0.45	LL	0.75	LLS	0.75	SL	0.75	SLN	0.75		
13	IBC 21/ASCE ASD 6 (c)	Yes		DL	1	WL	0.45	LL	0.75	LLS	0.75						
14	IBC 21/ASCE ASD 7	Yes		DL	0.6	WL	0.6										
15	IBC 21/ASCE ASD 8 (a)	Yes		DL	1	Sds*DL	0.14	ELX	0.7								
16	IBC 21/ASCE ASD 8 (b)	Yes		DL	1	Sds*DL	0.14	ELZ	0.7								
17	IBC 21/ASCE ASD 9 (a)	Yes		DL	1	Sds*DL	0.105	ELX	0.525	LL	0.75	LLS	0.75	SL	0.75	SLN	0.75
18	IBC 21/ASCE ASD 9 (b)	Yes		DL	1	Sds*DL	0.105	ELZ	0.525	LL	0.75	LLS	0.75	SL	0.75	SLN	0.75
19	IBC 21/ASCE ASD 10 (a)	Yes		DL	0.6	Sds*DL	-0.14	ELX	0.7								
20	IBC 21/ASCE ASD 10 (b)	Yes		DL	0.6	Sds*DL	-0.14	ELZ	0.7								

Envelope Node Reactions

Node Label	X [k]	LC	Y [k]	LC	Z [k]	LC	MX [k-ft]	LC	MY [k-ft]	LC	MZ [k-ft]	LC
0 N4 max	0.3212	15	0	20	0.2412	20	0	20	0	20	0	20
1 min	0	2	0	1	-0.2893	10	0	1	0	1	0	1
2 N3 max	0.1799	15	0	20	0.1592	20	0	20	0	20	0	20
3 min	0	2	0	1	-0.2353	10	0	1	0	1	0	1
4 N1 max	0.0968	6	0.454	6	0.1706	14	0	20	0	20	0	20
5 min	0	2	0	2	-0.1112	16	0	1	0	1	0	1
6 N2 max	0	2	1.331	6	0.1189	14	0	20	0	20	0	20
7 min	-0.3025	6	0	2	-0.0647	16	0	1	0	1	0	1
8 WP1 max	0.4422	19	9.8801	6	0.5851	20	0	20	0.0949	20	2.6861	10
9 min	-0.147	6	0	2	-0.8016	10	0	1	-0.7132	10	0	2
10 Totals: max	0.8095	19	11.6651	6	0.8095	20						
11 min	0	6	0	2	-1.0368	10						

Envelope Wall Panel Forces

Wall Label	Elevation [ft]	Axial [k]	LC	x Shear [k]	LC	z Shear [k]	LC	x-x Moment [k-ft]	LC	z-z Moment [k-ft]	LC
0 WP1 0 max		11.6651	6	0.4206	19	0.4092	20	0.0002	14	8.0231	6
1 0 min		0	2	-0.3527	6	-0.4986	10	-0.0002	16	0	2

Masonry Wall Reinforcement

Wall	Region	Hor. Bar Size	Vert. Bar Size	Boundary Reinf.
0 WP1	R1	#4@120 oc	#4@48" oc (ctr)	1-#4
1	R2	Not Req'd.	#4@48" oc (ctr)	1-#4
2	R3	Not Req'd.	#4@48" oc (ctr)	1-#4
3	R4	#4@120 oc	#4@48" oc (ctr)	1-#4
4	R5	Not Req'd.	#4@48" oc (ctr)	1-#4
5	R6	#4@120 oc	#4@48" oc (ctr)	1-#4

Masonry Lintel Reinforcement

Wall	Lintel	Flex. Steel	Stirrup
0 WP1	L1	2-#4	Not Req'd.

TMS 402-16: ASD Wall Panel Masonry Code Checks (In-Plane)

Wall Panel	Region	Design Rule	Combined UC	LC	Shear UC	LC	Fa[ksi]	Fb[ksi]	Fv[ksi]
0 WP1	R1	Typical	0.0734	6	0.052	6	0.3386	0.675	0.0738
1	R2	Typical	0	N/A	0	N/A	0.3741	0.675	0
2	R3	Typical	0	N/A	0	N/A	0.3699	0.675	0
3	R4	Typical	0.1813	6	0.0281	6	0.3386	0.675	0.0816
4	R5	Typical	0	N/A	0	N/A	0.3741	0.675	0
5	R6	Typical	0.1095	6	0.0912	6	0.3386	0.675	0.0493

TMS 402-16: ASD Wall Panel Masonry Code Checks (Out-of-Plane)

Wall Panel	Region	Design Rule	Combined UC	LC	Shear UC	LC	Fa[ksi]	Fb[ksi]	Fv[ksi]
0 WP1	R1	Typical	0.3586	10	0.0122	10	0.3386	0.675	0.0736
1	R2	Typical	0	N/A	0	N/A	0.3741	0.675	0.0387
2	R3	Typical	0	N/A	0	N/A	0.3699	0.675	0.0387
3	R4	Typical	0.3974	10	0.019	10	0.3386	0.675	0.0634
4	R5	Typical	0	N/A	0	N/A	0.3741	0.675	0.0387
5	R6	Typical	0.3454	10	0.0323	10	0.3386	0.675	0.0588



Company : <Licensed Company>
 Designer : szejidman
 Job Number :
 Model Name :

1.10
 9/8/2023
 1:44:07 PM
 Checked By : _____

Wall Panel TMS 402-16: ASD Masonry Code Checks for Lintels

Wall Panel	Lintel	Design Rule	Flexure UC	LC	Shear UC	LC	Fvm[ksi]	Fvs[ksi]	Fm[ksi]	Fs[ksi]	
0	WP1	L1	Typical	0.984	6	0.3788	6	0.0775	0	0.5	32

Material Take-Off

	Material	Pieces	Length[ft]	Weight[K]
0	Masonry Walls		Volume (yds^3)	
1	Concrete Matl	1	1.6	3.5551
2	Total Masonry	1	1.6	3.5551

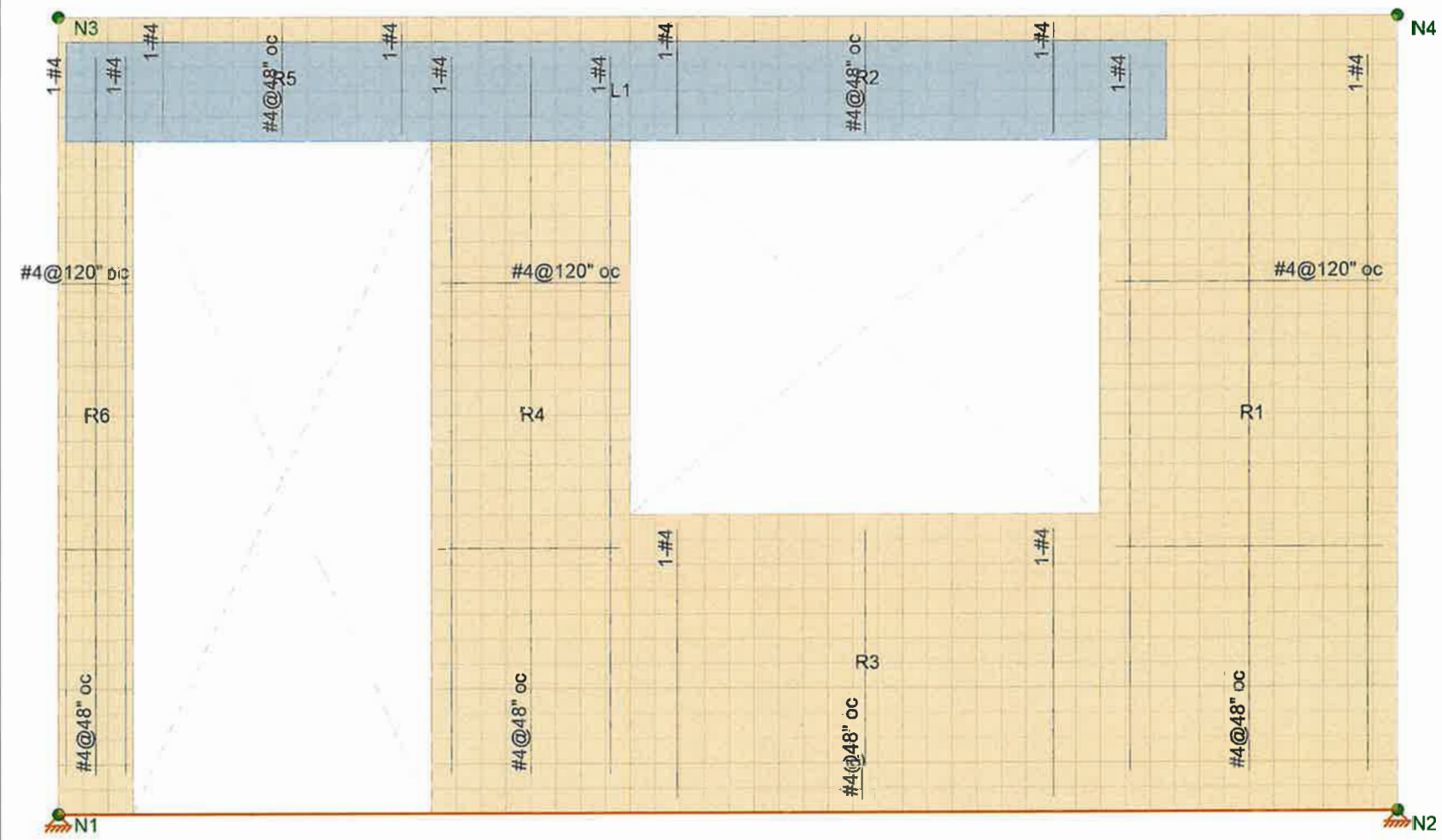
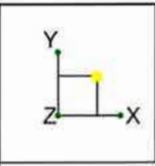

	<Licensed Company>	SK-1
	szeidman	Sep 07, 2023 at 04:57 PM
		wall panel.r3d

Detail Report: WP1

Masonry Wall

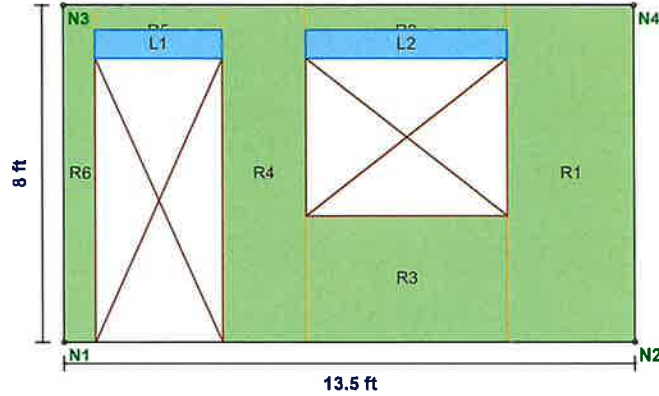

CRITERIA

Code:	TMS 402-16: ASD
Special Insp:	No
Design Rule:	Typical
Seismic Design Rule:	Ordinary
Wall Area:	NCMA
Transfer In?:	Yes
Transfer Out?:	Yes
K:	1
Use Cracked?:	Yes
In Icr Factor:	0.5
Out Icr Factor:	0.5
Custom Regions:	No

GEOMETRY

Total Height (ft):	8
Total Length (ft):	13.5
Total Lintel Depth (in):	12
Block Nom Width:	8"
Block Grouting:	Fully Grouted
1.5 Shear Factor:	No

MATERIALS

Material Type:	Masonry
Material Set:	Concrete Matl
Masonry f'm (ksi):	1.5
Masonry Em (ksi):	1350
Steel fy (ksi):	60
Steel E (ksi):	29000
Block Material:	Conc 115 pcf
Grout Weight:	140 pcf
Mortar Type:	Type M or S
Cement Type:	Portland, Lime/Mort:

REGION RESULTS

Region	UC Max In Plane	LC	UC Shear In Plane	LC	UC Max Out Plane	LC	UC Shear Out Plane	L
R1	0.0546	6	0.0417	6	0.3562	10	0.0123	1
R4	0.2002	6	0.0388	6	0.397	10	0.019	1
R6	0.1132	6	0.1459	6	0.3486	10	0.0329	1

REINFORCEMENT RESULTS

Region	Vertical Reinforcement	Horizontal Reinforcement	Boundary Reinforcement
R1	#4@48" oc ctr	#4@120 oc	1-#4 ctr
R4	#4@48" oc ctr	#4@120 oc	1-#4 ctr
R6	#4@48" oc ctr	#4@120 oc	1-#4 ctr



Company : <Licensed Company>
Designer : szejidman
Job Number :
Model Name :

9/7/2023 1.13
4:51:22 PM
Checked By : _____

LINTEL REINFORCEMENT RESULTS

Lintel	Flexural Reinforcement	Shear Reinforcement
L1	1-#4	Not Reqd.
L2	1-#4	Not Reqd.

www.hilti.com

Company:
 Address:
 Phone | Fax:
 Design: Concrete - Sep 8, 2023
 Fastening point:

Page: 1
 Specifier:
 E-Mail:
 Date: 9/8/2023

Specifier's comments:

1 Input data



Anchor type and diameter:	HIT-HY 200 V3 + Rebar A 615 Gr.60 #4
Item number:	not available (element) / 2334276 HIT-HY 200-R V3 (adhesive)
Effective embedment depth:	$h_{ef,opt} = 2.750$ in. ($h_{ef,limit} = 3.750$ in.)
Material:	ASTM A 615 GR.60
Evaluation Service Report:	ESR-4868
Issued Valid:	11/1/2022 11/1/2024
Proof:	Design Method ACI 318-14 / Chem
Stand-off installation:	
Profile:	
Base material:	cracked concrete, 2500 , $f_c' = 2,500$ psi; $h = 5.000$ in., Temp. short/long: 32/32 °F
Installation:	hammer drilled hole, Installation condition: Dry
Reinforcement:	tension: condition B, shear: condition B; no supplemental splitting reinforcement present edge reinforcement: none or < No. 4 bar
Seismic loads (cat. C, D, E, or F)	Tension load: yes (17.2.3.4.3 (d)) Shear load: yes (17.2.3.5.3 (c))

Geometry [in.] & Loading [lb, in.lb]

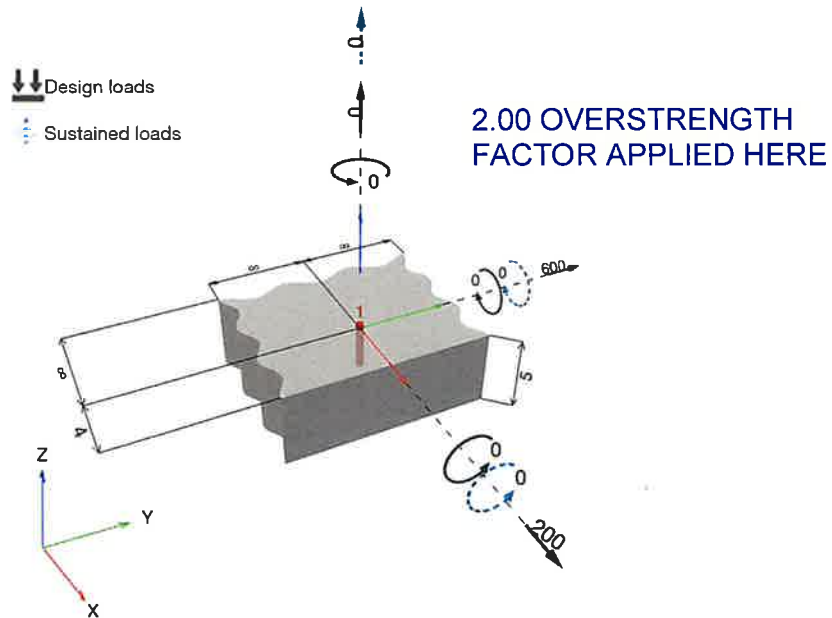

Input data and results must be checked for conformity with the existing conditions and for plausibility!
 PROFIS Engineering (c) 2003-2023 Hilti AG, FL-9494 Schaan Hilti is a registered Trademark of Hilti AG, Schaan

**Hilti PROFIS Engineering 3.0.88**

www.hilti.com

Company:		Page:	2
Address:		Specifier:	
Phone Fax:		E-Mail:	
Design:	Concrete - Sep 8, 2023	Date:	9/8/2023
Fastening point:			

1.1 Design results

Case	Description	Forces [lb] / Moments [in.lb]	Seismic	Max. Util. Anchor [%]
1	Combination 1	N = 0; V _x = 200; V _y = 600; M _x = 0; M _y = 0; M _z = 0; N _{sus} = 0; M _{x,sus} = 0; M _{y,sus} = 0;	yes	36

2 Load case/Resulting anchor forces**Anchor reactions [lb]**

Tension force: (+Tension, -Compression)

Anchor	Tension force	Shear force	Shear force x	Shear force y
1	0	632	200	600

max. concrete compressive strain: - [%a]
max. concrete compressive stress: - [psi]
resulting tension force in (x/y)=(0.000/0.000): 0 [lb]
resulting compression force in (x/y)=(0.000/0.000): 0 [lb]

3 Tension load

	Load N _{ua} [lb]	Capacity ϕ N _n [lb]	Utilization $\beta_N = N_{ua}/\phi N_n$	Status
Steel Strength*	N/A	N/A	N/A	N/A
Bond Strength**	N/A	N/A	N/A	N/A
Sustained Tension Load Bond Strength*	N/A	N/A	N/A	N/A
Concrete Breakout Failure**	N/A	N/A	N/A	N/A

* highest loaded anchor **anchor group (anchors in tension)

www.hilti.com

Company:

Address:

Phone | Fax:

Design:

Fastening point:

Concrete - Sep 8, 2023

Page:

Specifier:

E-Mail:

Date:

3

9/8/2023

4 Shear load

	Load V_{ua} [lb]	Capacity ϕV_n [lb]	Utilization $\beta_V = V_{ua}/\phi V_n$	Status
Steel Strength*	632	4,032	16	OK
Steel failure (with lever arm)*	N/A	N/A	N/A	N/A
Pryout Strength (Bond Strength controls)**	632	3,948	17	OK
Concrete edge failure in direction x+**	632	1,779	36	OK

* highest loaded anchor **anchor group (relevant anchors)

4.1 Steel Strength

V_{sa} [lb]	$\alpha_{V,seis}$	ϕ	ϕV_{sa} [lb]	V_{ua} [lb]
6,720	0.700	0.600	4,032	632

4.2 Pryout Strength (Bond Strength controls)

A_{Na} [in. ²]	A_{Na0} [in. ²]	c_{Na} [in.]	$c_{a,min}$ [in.]	c_{ac} [in.]		
117.72	140.59	5.928	4.000	5.205		
$\alpha_{overhead}$	$\tau_{k,uncr}$ [psi]	$\tau_{k,cr}$ [psi]				
1.000	1,561	1,080				
$e_{c1,N}$ [in.]	$\psi_{ec1,Na}$	$e_{c2,N}$ [in.]	$\psi_{ec2,Na}$	$\psi_{ed,Na}$	$\psi_{cp,Na}$	$\alpha_{N,seis}$
0.000	1.000	0.000	1.000	0.902	1.000	0.800
λ_a	N_{ba} [lb]	ϕ	$\phi_{seismic}$	$\phi_{nonductile}$	ϕV_{cpg} [lb]	V_{ua} [lb]
1.000	3,732	0.700	1.000	1.000	3,948	632

4.3 Concrete edge failure in direction x+

l_e [in.]	d_a [in.]	c_{a1} [in.]	A_{Vc} [in. ²]	A_{Vc0} [in. ²]	
2.750	0.500	4.000	60.00	72.00	
$\psi_{ed,v}$	$\psi_{parallel,v}$	$e_{c,v}$ [in.]	$\psi_{ec,v}$	$\psi_{c,v}$	$\psi_{h,v}$
1.000	1.000	0.000	1.000	1.000	1.095
λ_a	V_b [lb]	ϕ	$\phi_{seismic}$	ϕV_{cbg} [lb]	V_{ua} [lb]
1.000	2,784	0.700	1.000	1,779	632

**Hilti PROFIS Engineering 3.0.88****www.hilti.com**

Company:

Address:

Phone | Fax:

Design:

Fastening point:

Concrete - Sep 8, 2023

Page:

Specifier:

E-Mail:

Date:

4

9/8/2023

5 Warnings

- The anchor design methods in PROFIS Engineering require rigid anchor plates per current regulations (AS 5216:2021, ETAG 001/Annex C, EOTA TR029 etc.). This means load re-distribution on the anchors due to elastic deformations of the anchor plate are not considered - the anchor plate is assumed to be sufficiently stiff, in order not to be deformed when subjected to the design loading. PROFIS Engineering calculates the minimum required anchor plate thickness with CBFEM to limit the stress of the anchor plate based on the assumptions explained above. The proof if the rigid anchor plate assumption is valid is not carried out by PROFIS Engineering. Input data and results must be checked for agreement with the existing conditions and for plausibility!
- Condition A applies where the potential concrete failure surfaces are crossed by supplementary reinforcement proportioned to tie the potential concrete failure prism into the structural member. Condition B applies where such supplementary reinforcement is not provided, or where pullout or pryout strength governs.
- Design Strengths of adhesive anchor systems are influenced by the cleaning method. Refer to the INSTRUCTIONS FOR USE given in the Evaluation Service Report for cleaning and installation instructions.
- For additional information about ACI 318 strength design provisions, please go to <https://submittals.us.hilti.com/PROFISAnchorDesignGuide/>
- An anchor design approach for structures assigned to Seismic Design Category C, D, E or F is given in ACI 318-14, Chapter 17, Section 17.2.3.4.3 (a) that requires the governing design strength of an anchor or group of anchors be limited by ductile steel failure. If this is NOT the case, the connection design (tension) shall satisfy the provisions of Section 17.2.3.4.3 (b), Section 17.2.3.4.3 (c), or Section 17.2.3.4.3 (d). The connection design (shear) shall satisfy the provisions of Section 17.2.3.5.3 (a), Section 17.2.3.5.3 (b), or Section 17.2.3.5.3 (c).
- Section 17.2.3.4.3 (b) / Section 17.2.3.5.3 (a) require the attachment the anchors are connecting to the structure be designed to undergo ductile yielding at a load level corresponding to anchor forces no greater than the controlling design strength. Section 17.2.3.4.3 (c) / Section 17.2.3.5.3 (b) waive the ductility requirements and require the anchors to be designed for the maximum tension / shear that can be transmitted to the anchors by a non-yielding attachment. Section 17.2.3.4.3 (d) / Section 17.2.3.5.3 (c) waive the ductility requirements and require the design strength of the anchors to equal or exceed the maximum tension / shear obtained from design load combinations that include E, with E increased by ω_p .
- Installation of Hilti adhesive anchor systems shall be performed by personnel trained to install Hilti adhesive anchors. Reference ACI 318-14, Section 17.8.1.

Fastening meets the design criteria!

**Hilti PROFIS Engineering 3.0.88****www.hilti.com**

Company:

Address:

Phone | Fax:

Design:

Fastening point:

Concrete - Sep 8, 2023

Page:

Specifier:

E-Mail:

Date:

5

9/8/2023

6 Installation data

Profile: -

Hole diameter in the fixture: -

Plate thickness (input): -

Drilling method: Hammer drilled

Cleaning: Compressed air cleaning of the drilled hole according to instructions for use is required

#4 Rebar with Hilti HIT-HY 200 V3 Safe Set System

Anchor type and diameter: HIT-HY 200 V3 + Rebar A 615
Gr.60 #4Item number: not available (element) / 2334276 HIT-HY
200-R V3 (adhesive)

Maximum installation torque: -

Hole diameter in the base material: 0.625 in.

Hole depth in the base material: 2.750 in.

Minimum thickness of the base material: 4.000 in.

6.1 Recommended accessories**Drilling**

- Suitable Rotary Hammer
- Properly sized drill bit

Cleaning

- Compressed air with required accessories to blow from the bottom of the hole
- Proper diameter wire brush

Setting

- Dispenser including cassette and mixer
- For deep installations, a piston plug is necessary
- Torque wrench

Coordinates Anchor in.

Anchor	x	y	c _{-x}	c _{+x}	c _{-y}	c _{+y}
1	0.000	0.000	-	4.000	-	-



Hilti PROFIS Engineering 3.0.88**www.hilti.com**

Company:

Address:

Phone | Fax:

Design:

Fastening point:

Concrete - Sep 8, 2023

Page:

Specifier:

E-Mail:

Date:

6

9/8/2023

7 Remarks; Your Cooperation Duties

- Any and all information and data contained in the Software concern solely the use of Hilti products and are based on the principles, formulas and security regulations in accordance with Hilti's technical directions and operating, mounting and assembly instructions, etc., that must be strictly complied with by the user. All figures contained therein are average figures, and therefore use-specific tests are to be conducted prior to using the relevant Hilti product. The results of the calculations carried out by means of the Software are based essentially on the data you put in. Therefore, you bear the sole responsibility for the absence of errors, the completeness and the relevance of the data to be put in by you. Moreover, you bear sole responsibility for having the results of the calculation checked and cleared by an expert, particularly with regard to compliance with applicable norms and permits, prior to using them for your specific facility. The Software serves only as an aid to interpret norms and permits without any guarantee as to the absence of errors, the correctness and the relevance of the results or suitability for a specific application.
- You must take all necessary and reasonable steps to prevent or limit damage caused by the Software. In particular, you must arrange for the regular backup of programs and data and, if applicable, carry out the updates of the Software offered by Hilti on a regular basis. If you do not use the AutoUpdate function of the Software, you must ensure that you are using the current and thus up-to-date version of the Software in each case by carrying out manual updates via the Hilti Website. Hilti will not be liable for consequences, such as the recovery of lost or damaged data or programs, arising from a culpable breach of duty by you.

www.hilti.com

Company:

Address:

Phone | Fax:

Design:

Fastening point:

Masonry - Sep 8, 2023

Page:

Specifier:

E-Mail:

Date:

1

9/8/2023

Specifier's comments:

1 Input data

Anchor type and diameter:	HY 270 + Rebar A615 Gr.60 #4
Item number:	not available (element) / 2194247 HIT-HY 270 (adhesive)
Effective embedment depth:	$h_{ef} = 4.500$ in.
Material:	ASTM A 615 GR.60
Evaluation Service Report:	Hilti Technical Data
Issued Valid:	- -
Proof:	Design Method ASD Masonry
Stand-off installation:	
Profile:	
Base material:	Grout-filled CMU, L x W x H: 16.000 in. x 8.000 in. x 8.000 in.;
	Joints: vertical: 0.375 in.; horizontal: 0.375 in.
	Base material temperature: 68 °F
Installation:	Side/end installation
Seismic loads	yes



Geometry [in.]

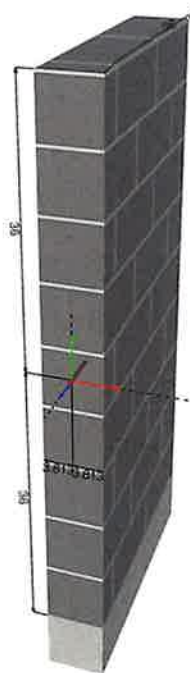

www.hilti.com

Company:
 Address:
 Phone | Fax: |
 Design: Masonry - Sep 8, 2023
 Fastening point:

Page: 2
 Specifier:
 E-Mail:
 Date: 9/8/2023

Geometry [in.] & Loading [lb, in.lb]

2.00 OVERSTRENGTH
 FACTOR APPLIED HERE

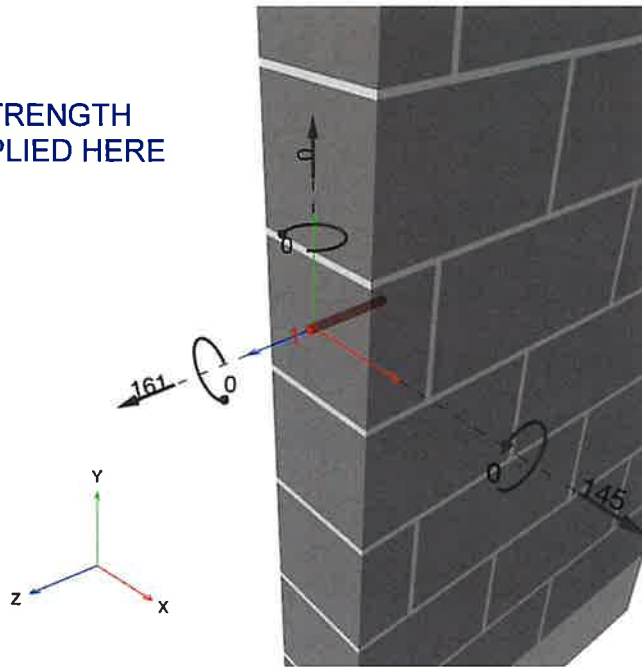

1.1 Design results

Case	Description	Forces [lb] / Moments [in.lb]	Seismic	Max. Util. Anchor [%]
1	Combination 1	N = 161; V _x = 145; V _y = 0; M _x = 0; M _y = 0; M _z = 0;	yes	73

2 Load case/Resulting anchor forces

Load case: Service loads

Anchor reactions [lb]

Tension force: (+Tension, -Compression)

Anchor	Tension force	Shear force	Shear force x	Shear force y
1	161	145	145	0

max. compressive strain: - [%]
 max. compressive stress: - [psi]
 resulting tension force in (x/y)=(0.000/0.000): 0 [lb]
 resulting compression force in (x/y)=(0.000/0.000): 0 [lb]

www.hilti.com

Company:

Address:

Phone | Fax:

Design:

Fastening point:

Masonry - Sep 8, 2023

Page:

Specifier:

E-Mail:

Date:

3

9/8/2023

3 Tension load (Most utilized anchor 1)

	Load P_s [lb]	Capacity P_t [lb]	Utilization $B_P = P_s/P_t$ [%]	Status
Steel strength	161	5,940	3	OK
Bond strength	161	1,055	16	OK

3.1 Steel strength

 $P_{t,s}$ = Value refer to Hilti Technical Data

 $P_{t,s} \geq P_s$

Results

$P_{t,s}$ [lb]	P_s [lb]
5,940	161

3.2 Bond strength

 $P_{t,b,Base}$ = Value refer to Hilti Technical Data

 $P_{t,b} = P_{t,b,Base} \cdot f_{red,E} \cdot f_{red,s} \cdot f_{red,Temp}$
 $P_{t,b} \geq P_s$

Variables

c_{min} [in.]	c_{cr} [in.]	s_{min} [in.]	s_{cr} [in.]	Temperature [°F]
1.750	-	-	-	68

Results

$P_{t,b}$ [lb]	$P_{t,b,Base}$ [lb]	P_s [lb]	$f_{red,E}$	$f_{red,S}$	$f_{red,Temp}$
1,055	1,055	161	1.000	1.000	1.000

www.hilti.com

Company:		Page:	4
Address:		Specifier:	
Phone Fax:		E-Mail:	
Design:	Masonry - Sep 8, 2023	Date:	9/8/2023
Fastening point:			

4 Shear load (Most utilized anchor 1)

	Load V_s [lb]	Capacity V_t [lb]	Utilization $\beta_V = V_s/V_t$ [%]	Status
Steel strength	145	3,060	5	OK
Bond strength para and perp, (Dir. x+) ¹	-	-	57	OK

¹Shear utilization may result from parallel and perpendicular shear (see details)

4.1 Steel strength

$V_{t,s}$ = Value refer to Hilti Technical Data

$$V_{t,s} \geq V_s$$

Results

$V_{t,s}$ [lb]	V_s [lb]
3,060	145

4.2 Bond strength parallel

$V_{t,b,Base,\parallel}$ = Value refer to Hilti Technical Data

$$V_{t,b,\parallel} = V_{t,b,Base,\parallel} \cdot f_{red,E,\parallel} \cdot f_{red,s,\parallel} \cdot f_{red,Temp}$$

$$V_{t,b,\parallel} \geq V_{s,\parallel}$$

Variables

c_{min} [in.]	c_{cr} [in.]	s_{min} [in.]	s_{cr} [in.]	Temperature [°F]
1.750	-	-	-	68

Results

$V_{t,b,\parallel}$ [lb]	$V_{t,b,Base,\parallel}$ [lb]	$V_{s,\parallel}$ [lb]	$f_{red,E,\parallel}$	$f_{red,S,\parallel}$	$f_{red,Temp}$	Utilization $\beta_{V,\parallel}$ [%]
0	835	0	0.000	0.000	1.000	0

4.3 Bond strength perpendicular

$V_{t,b,Base,\perp}$ = Value refer to Hilti Technical Data

$$V_{t,b,\perp} = V_{t,b,Base,\perp} \cdot f_{red,E,\perp} \cdot f_{red,s,\perp} \cdot f_{red,Temp}$$

$$V_{t,b,\perp} \geq V_{s,\perp}$$

Variables

c_{min} [in.]	c_{cr} [in.]	s_{min} [in.]	s_{cr} [in.]	Temperature [°F]
1.750	-	-	-	68

Results

$V_{t,b,\perp}$ [lb]	$V_{t,b,Base,\perp}$ [lb]	$V_{s,\perp}$ [lb]	$f_{red,E,\perp}$	$f_{red,S,\perp}$	$f_{red,Temp}$	Utilization $\beta_{V,\perp}$ [%]
255	255	145	1.000	1.000	1.000	57

Hilti PROFIS Engineering 3.0.88

www.hilti.com

Company:		Page:	5
Address:		Specifier:	
Phone Fax:		E-Mail:	
Design:	Masonry - Sep 8, 2023	Date:	9/8/2023
Fastening point:			

4.4 Shear interaction

$\beta_{V, } = \frac{V_{s, }}{V_{t, }}$	$\beta_{V,\perp} = \frac{V_{s,\perp}}{V_{t,\perp}}$	δ	Utilization β_V [%]	Status
0.000	0.569	1.000	57	OK

$$\beta_V = \beta_{V,||}^{\delta} + \beta_{V,\perp}^{\delta} \leq 1.0$$

5 Combined tension and shear loads (Most utilized anchor 1)

$\beta_P = \frac{P_s}{P_t}$	$\beta_{V, } = \frac{V_{s, }}{V_{t, }}$	$\beta_{V,\perp} = \frac{V_{s,\perp}}{V_{t,\perp}}$	α	Utilization $\beta_{P,V}$ [%]	Status
0.153	0.000	0.569	1.000	73	OK

$$\beta_{P,V} = \beta_P^{\alpha} + \beta_{V,||}^{\alpha} + \beta_{V,\perp}^{\alpha} \leq 1.0$$

6 Warnings

- The anchor design methods in PROFIS Engineering require rigid anchor plates per current regulations (AS 5216:2021, ETAG 001/Annex C, EOTA TR029 etc.). This means load re-distribution on the anchors due to elastic deformations of the anchor plate are not considered - the anchor plate is assumed to be sufficiently stiff, in order not to be deformed when subjected to the design loading. PROFIS Engineering calculates the minimum required anchor plate thickness with CBFEM to limit the stress of the anchor plate based on the assumptions explained above. The proof if the rigid anchor plate assumption is valid is not carried out by PROFIS Engineering. Input data and results must be checked for agreement with the existing conditions and for plausibility!
- Refer to the manufacturer's product literature for cleaning and installation instructions.
- For additional information about ACI 318 strength design provisions, please go to <https://submittals.us.hilti.com/PROFISAnchorDesignGuide/>
- The min. sizes of the bricks, the masonry compressive strength, the type / strength of the mortar and the grout (in case of fully grouted CMU walls) has to fulfill the requirements given in the relevant ESR-approval or in the PTG.
- Only the local load transfer from the anchor(s) to the wall is considered, a further load transfer in the wall is not covered by PROFIS!
- Wall is assumed as being perfectly aligned vertically – checking required(!): Noncompliance can lead to significantly different distribution of forces and higher tension loads than those calculated by PROFIS. Masonry wall must not have any damages (neither visible nor not visible)! While installation, the positioning of the anchors needs to be maintained as in the design phase i.e. either relative to the brick or relative to the mortar joints.
- The effect of the joints on the compressive stress distribution on the plate / bricks was not taken into consideration.
- If no significant resistance is felt over the entire depth of the hole when drilling (e.g. in infilled butt joints), the anchor should not be set at this position or the area should be assessed and reinforced. Hilti recommends the anchoring in masonry always with sieve sleeve. Anchors can only be installed without sieve sleeves in solid bricks when it is guaranteed that it has not any hole or void.
- The accessories and installation remarks listed on this report are for the information of the user only. In any case, the instructions for use provided with the product have to be followed to ensure a proper installation.
- The compliance with current standards (e.g. 2018, 2015, 2012, 2009 and 2006 IBC) is the responsibility of the user.
- Drilling method (hammer, rotary) to be in accordance with the approval!
- Masonry needs to be built in a regular way in accordance with state-of the art guidelines!

Fastening meets the design criteria!

**Hilti PROFIS Engineering 3.0.88****www.hilti.com**

Company:

Address:

Phone | Fax:

Design:

Fastening point:

Masonry - Sep 8, 2023

Page:

Specifier:

E-Mail:

Date:

6

9/8/2023

7 Installation data

Profile: -

Hole diameter in the fixture: -

Plate thickness (input): -

Drilling method: Drilled in hammer mode

Anchor type and diameter: HY 270 + Rebar A615 Gr.60
#4Item number: not available (element) / 2194247 HIT-HY
270 (adhesive)

Maximum installation torque: - in.lb

Hole diameter in the base material: 0.625 in.

Hole depth in the base material: 4.500 in.

Minimum thickness of the base material: 7.625 in.

Rebar with HIT-HY 270 injection mortar with 4.5 in embedment h_{ef} , #4, Hammer drilled installation per instruction for use**Coordinates Anchor in.**

Anchor	x	y	c_{-x}	c_{+x}	c_{-y}	c_{+y}
1	0.000	0.000	3.812	3.812	36.000	36.000



Hilti PROFIS Engineering 3.0.88**www.hilti.com**

Company:

Address:

Phone | Fax:

Design:

Fastening point:

|
Masonry - Sep 8, 2023

Page:

Specifier:

E-Mail:

Date:

79/8/2023

8 Remarks; Your Cooperation Duties

- Any and all information and data contained in the Software concern solely the use of Hilti products and are based on the principles, formulas and security regulations in accordance with Hilti's technical directions and operating, mounting and assembly instructions, etc., that must be strictly complied with by the user. All figures contained therein are average figures, and therefore use-specific tests are to be conducted prior to using the relevant Hilti product. The results of the calculations carried out by means of the Software are based essentially on the data you put in. Therefore, you bear the sole responsibility for the absence of errors, the completeness and the relevance of the data to be put in by you. Moreover, you bear sole responsibility for having the results of the calculation checked and cleared by an expert, particularly with regard to compliance with applicable norms and permits, prior to using them for your specific facility. The Software serves only as an aid to interpret norms and permits without any guarantee as to the absence of errors, the correctness and the relevance of the results or suitability for a specific application.
- You must take all necessary and reasonable steps to prevent or limit damage caused by the Software. In particular, you must arrange for the regular backup of programs and data and, if applicable, carry out the updates of the Software offered by Hilti on a regular basis. If you do not use the AutoUpdate function of the Software, you must ensure that you are using the current and thus up-to-date version of the Software in each case by carrying out manual updates via the Hilti Website. Hilti will not be liable for consequences, such as the recovery of lost or damaged data or programs, arising from a culpable breach of duty by you.

Appendix A

Reference
Documents



DAMAGE ASSESSMENT INSPECTION REPORT
DEPARTMENT OF COMMUNITY DEVELOPMENT

MAP # 02324-67
DATE: 5-31-23 A1
MTG # 23-00163
[X] FIRE
[X] WATER
[X] OTHER

COLLECT \$: 34400 FEE W/PERMIT

INSPECTOR #: 10 BLDG POSTED: 6-6-23

ADDRESS: 802 Mc Williams Ave

NAME OF BUSINESS: SAVRHA

OWNER/REPRESENTATIVE: DARRYL CHINN PHONE # 702-363-3781

USE OF BUILDING: [X]APT/CONDO []COMMERCIAL []SFD [X]VEHICLE []WALL

DESCRIBE SPECIFIC AREAS POSTED: CMU EXTERIOR WALL

The items identified below need to be addressed in order to be in compliance. If an item that is marked "P" needs to be submitted for plan review and if it is marked "I" it needs to be provided to the inspector in the field once the permit is issued.

BUILDING:

P I

- 1. [] [] Replace Drywall; Ceiling Panels: PATCH / REPAIR
2. [] [] Replace Roof/Sheathing: N/A
3. [] [] Replace Framing: N/A
4. [] [] Replace Windows; Doors: REPAIR EXTERIOR ENTRY DOOR
5. [] [] Slab Damage: N/A
6. [] [] Replace Rafters or Trusses: N/A
7. [] [] Replace or Repair Stucco: N/A
8. [] [] Other: PROVIDE STRUCTURAL ENGINEER FIX FOR CMU WALL

PLUMBING/MECHANICAL

- 1. [] [] Replace Gas Pipe: N/A
2. [] [] Replumb Rooms: N/A
3. [] [] Replace Fixtures: N/A
4. [] [] Replace AC Unit(s): N/A
5. [] [] Replace Ducts: N/A
6. [] [] Replace Hood: N/A
7. [] [] Other: N/A

ELECTRICAL

- 1. [] [] Replace Service: N/A
2. [] [] Rewire Rooms: MISC ELECTRICAL REPAIR
3. [] [] Other: N/A

COMMENTS & RECOMMENDATIONS:

REQUIRED INSPECTIONS- 101, 131, 140, 220, 240
DO NOT SUBMIT ENGINEER FIX (DETAILS)
PROVIDE COPY FOR INSPECTOR IN THE FIELD
NO PLANS

ESTIMATED DAMAGE TO STRUCTURE:

WALL [X]10% or Less []10%-25% []25% - 50% []50% - 75% []75% or more (new structure to be built)

PERMITS ARE REQUIRED FOR REPAIRS OF BUILDING, ELECTRICAL, PLUMBING AND MECHANICAL DAMAGE
FOR FURTHER INFORMATION, CALL THE CITY OF LAS VEGAS BUILDING DEPARTMENT AT 702.229.6251.

E-mail: DCHINN@SAVRHA.ORG



Geotechnical & Environmental Sciences Consultants

August 28, 2023
Proposal No. 07LAS03-00390



Ms. Deena Williams
Development and Modernization Specialist
Southern Nevada Regional Housing Authority
340 North 11th Street, Suite 150
Las Vegas, Nevada 89101

Subject: Proposed Phase I Environmental Site Assessment
Marble Manor
1310 West McWilliams Avenue
Las Vegas, Clark County, Nevada 89106
APN 139-28-702-001

Dear Ms. Williams:

Ninyo & Moore is pleased to submit our proposed scope of services and fee to perform a Phase I Environmental Site Assessment for the subject site located in Las Vegas, Nevada. It is understood from the information you provided the Subject Property is developed as a residential community on one parcel encompassing a total of approximately 35.74 acres.

Our proposed study will follow the standard practices of the current ASTM International (ASTM) Standard Practice for Environmental Site Assessments Process (Standard E1527-21) and 40 Code of Federal Regulations (CFR) Part 312, Standards and Practices for All Appropriate Inquiries (AAI).

SCOPE OF SERVICES

Ninyo & Moore's proposed scope of services for the Phase I ESA will include the following:

- A review of a commercial computerized database search of federal and state environmental record sources for the site and for properties located within the search radii prescribed by ASTM for the respective environmental record sources. The objective of the database search review will be to evaluate locations where hazardous materials may have been used or stored and their possible effects on the site.
- A review of the site and site vicinity historical land use to evaluate past uses that may have contributed to the presence of environmental concerns at the site. Information that will be used to review the site history will include, but not necessarily be limited to, readily available historical aerial photographs, Sanborn Insurance Maps, building plans, Flood Zone Maps, and United States Geological Survey Topographic Maps.

- A site visit to visually observe and photograph site characteristics for possible contaminated surface soil or surface water, improperly stored hazardous materials, possible sources of polychlorinated biphenyls, and possible risks of site contamination from activities at the site.
- An interview of owner representatives and/or other individuals familiar with the properties, past site operations, and construction history, if readily available.
- A site vicinity reconnaissance to observe characteristics of adjacent or nearby properties for possible environmental influences on the site.
- Preparation of a Phase I ESA report that generally follows ASTM E1527-21 and describes the scope of the services, the findings which identify known or suspected recognized environmental conditions (RECs) on the site and in the surrounding area, our opinions as to the impact on the site of those conditions identified in the findings, and our conclusions summarizing the RECs and other conditions deemed relevant associated with the site.

UNDERSTANDINGS

The conditions outlined below will apply to the performance of the scope of services described herein.

- In accordance with Section 6.2 of ASTM Standard E 1527-21 and the United States Environmental Protection Agency's AAI rule (40 CFR Part 312 Section 312.25), it is the responsibility of the client to review environmental liens for the site subject to the environmental assessment or engage a title company to review such records. Lack of an environmental lien search conducted by a title professional may adversely affect the client's ability to qualify for the landowner liability protections pursuant to the Comprehensive Environmental Response, Compensation, and Liability Act (CERCLA). Evidence of environmental liens and/or activity and use limitations on the site, if discovered by the client during this review, shall be provided to the environmental consultant.
- In accordance with the ASTM E1527-21 standard, site-specific information will be requested, to be completed by the user of the report (the client) in the form of a customized questionnaire provided by Ninyo & Moore and/or an interview with a designated representative, at the client's discretion.
- The visual observations made by Ninyo & Moore will be limited to the surface area of the site assessed. Subsurface explorations, soil sampling, surface and groundwater sampling, materials sampling and chemical analyses are not included in this Phase I ESA proposal.

SCHEDULE

Following receipt of your written authorization to proceed, Ninyo & Moore will commence services described herein. Our report will be presented approximately three weeks after of receipt of written authorization to proceed. This time estimate is based on the expected time required for Federal, State, and local agencies to respond to requests for information.

Task	Time Needed to Perform Tasks
Field Assessment and Background Research (700 acre parcels)	0.5 Week
Field Assessment and Background Research (Gen-Tie Corridor/ Access Road)	0.5 Week
Data Analysis and Reporting	2 Weeks
Total	Up to 3 Weeks

FEE

Ninyo & Moore will provide these services on a lump sum basis in accordance with the breakdown presented in the table below:

Task	Total
Field Assessment and Background Research (35.74-acre parcel)	\$2,000.00
Data Analysis and Reporting	\$1,400.00
Total Without Radon Testing	\$3,400.00

In the event that a letter of reliance is requested following delivery of the Phase I ESA, a lump sum fee of \$500 (Five Hundred Dollars) per reliance letter will apply. Services beyond those presented in the scope of services herein will be billed in accordance with the attached Schedule of Fees.

Ninyo & Moore appreciates this opportunity to be of service to you. If it is acceptable as written, please provide a Task Order, which will serve as our Notice to Proceed. We look forward to continue our working relationship with you on this project.

Respectfully submitted,
NINYO & MOORE



Court Brooks, PG, CEM
 Principal Hydrogeologist

CJB/cas

**Ryze Claim Solutions**

Insured: Southern Nevada Regional Housing Authority
Property: 800-802 McWilliams
Las Vegas, NV 89106

Home: (702) 477-3173

Claim Rep.: Jack Van Arsdale
Business: 189 Commerce Court
Cheshire, CT 06410

Business: (800) 873-0242 x 410
E-mail: jvanarsdale@housingcenter.com

Estimator: Jacob Barcus NV
Business: PO Box 1140
Noblesville, IN 46061

Business: (702) 682-3365
E-mail: jacob.barcus@ryzeclaims.com

Claim Number: A8KD8

Policy Number: HAPI-484-226686-2022

Type of Loss: Vehicle

Date Contacted: 4/11/2023 2:02 PM

Date of Loss: 4/10/2023 12:00 AM

Date Inspected: 4/13/2023 9:00 AM

Date Received: 4/11/2023 11:01 AM

Date Entered: 4/20/2023 9:57 AM

Price List: NVLV8X_APR23
Restoration/Service/Remodel

Estimate: 23-024968



23-024968

Main Level

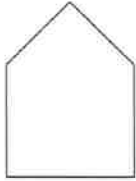

Front Elevation

Formula Elevation 58' 9" x 10' x 0"

511.88 SF Walls
 587.50 SF Long Wall
 58.75 LF Ceil. Perimeter

52.75 LF Floor Perimeter
 587.50 SF Short Wall

Missing Wall - Goes to Floor

(2) 3' X 6' 8"

Opens into Exterior

Missing Wall - Goes to neither Floor/Ceiling

(2) 4' 9" X 3' 9"

Opens into Exterior

QUANTITY	UNIT	TAX	O&P	RCV	AGE/LIFE	COND.	DEP %	DEPREC.	ACV
Paint brick									
511.88 SF	0.91	12.86	95.74	574.41	0/15 yrs	Avg.	0%	(0.00)	574.41
Totals: Front Elevation		12.86	95.74	574.41				0.00	574.41

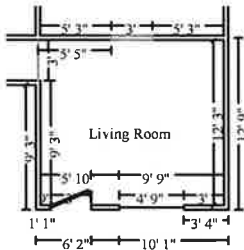

Living Room

Height: 8'

331.52 SF Walls
 497.40 SF Walls & Ceiling
 18.43 SY Flooring
 48.67 LF Ceil. Perimeter

165.88 SF Ceiling
 165.88 SF Floor
 42.67 LF Floor Perimeter

Missing Wall

3' X 8'

Opens into HALLWAY

Window

4' 9" X 3' 9"

Opens into Exterior

Door

3' X 6' 8"

Opens into Exterior

Missing Wall - Goes to Floor

3' X 6' 8"

Opens into KITCHEN

QUANTITY	UNIT	TAX	O&P	RCV	AGE/LIFE	COND.	DEP %	DEPREC.	ACV
Concrete wall - 8" x 8" - labor and material - Reinforced									
13.50 LF	100.87	35.64	279.48	1,676.87	0/200 yrs	Avg.	0%	(0.00)	1,676.87
R&R 5/8" drywall - hung, taped, floated, ready for paint									
108.00 SF	3.65	5.97	80.04	480.21	0/150 yrs	Avg.	0%	(0.00)	480.21
Tape joint for new to existing drywall - per LF									
13.50 LF	11.26	0.45	30.50	182.96	0/150 yrs	Avg.	0%	(0.00)	182.96

CONTINUED - Living Room

QUANTITY	UNIT	TAX	O&P	RCV	AGE/LIFE	COND.	DEP %	DEPREC.	ACV
Texture drywall - light hand texture									
273.88 SF	1.13	2.06	62.32	373.86	0/150 yrs	Avg.	0%	(0.00)	373.86
Mask wall - plastic, paper, tape (per LF)									
48.67 LF	1.72	1.10	16.96	101.77	0/150 yrs	Avg.	0%	(0.00)	101.77
R&R Batt insulation - 8" - R25 - unfaced batt									
108.00 SF	1.89	9.32	42.68	256.12	0/150 yrs	Avg.	0%	(0.00)	256.12
Seal the surface area w/latex based stain blocker - one coat									
108.00 SF	0.69	0.72	15.04	90.28	0/15 yrs	Avg.	0%	(0.00)	90.28
Paint the walls and ceiling - one coat									
497.40 SF	0.75	5.83	75.78	454.66	0/15 yrs	Avg.	0%	(0.00)	454.66
R&R Vinyl window, horizontal sliding, 12-23 sf									
1.00 EA	436.69	26.90	92.72	556.31	0/30 yrs	Avg.	0%	(0.00)	556.31
R&R Wood door frame & trim - exterior - hardwood									
20.00 LF	21.83	23.73	92.06	552.39	0/100 yrs	Avg.	0%	(0.00)	552.39
R&R Exterior door - metal - insulated - flush or panel style									
1.00 EA	513.63	31.93	109.10	654.66	0/100 yrs	Avg.	0%	(0.00)	654.66
R&R Door lockset & deadbolt - exterior									
1.00 EA	108.38	4.82	22.64	135.84	0/20 yrs	Avg.	0%	(0.00)	135.84
Prime & paint door slab only - exterior (per side)									
2.00 EA	51.46	2.52	21.08	126.52	0/15 yrs	Avg.	0%	(0.00)	126.52
Paint door or window opening - 2 coats (per side)									
2.00 EA	35.80	0.83	14.48	86.91	0/15 yrs	Avg.	0%	(0.00)	86.91
Rewire\wire - avg. residence - boxes & wiring									
108.00 SF	4.00	5.70	87.54	525.24	0/100 yrs	Avg.	0%	(0.00)	525.24
R&R Switch									
1.00 EA	23.22	0.24	4.68	28.14	0/25 yrs	Avg.	0%	(0.00)	28.14
R&R Outlet									
1.00 EA	22.42	0.17	4.52	27.11	0/25 yrs	Avg.	0%	(0.00)	27.11
R&R Outlet or switch cover									
2.00 EA	4.01	0.14	1.62	9.78	0/25 yrs	Avg.	0%	(0.00)	9.78
Floor preparation for resilient flooring									
165.88 SF	0.52	1.39	17.54	105.19	0/50 yrs	Avg.	0%	(0.00)	105.19
Remove Remove Vinyl tile*									
165.88 SF	1.32	0.00	43.80	262.76	0/50 yrs	Avg.	NA	(0.00)	262.76
Install Install Vinyl tile*									
165.88 SF	1.21	0.00	40.14	240.85	0/50 yrs	Avg.	0%	(0.00)	240.85
Material Only Vinyl tile - Materials Only*									
165.88 SF	2.21	30.70	79.46	476.75	0/50 yrs	Avg.	0%	(0.00)	476.75



CONTINUED - Living Room

QUANTITY	UNIT	TAX	O&P	RCV	AGE/LIFE	COND.	DEP %	DEPREC.	ACV
Contents - move out then reset									
1.00 EA	79.07	0.00	15.82	94.89	0/NA	Avg.	0%	(0.00)	94.89
Final cleaning - construction - Residential									
165.88 SF	0.37	0.00	12.28	73.66	0/NA	Avg.	0%	(0.00)	73.66
Totals: Living Room		190.16	1,262.28	7,573.73				0.00	7,573.73

Hallway

Height: 8'

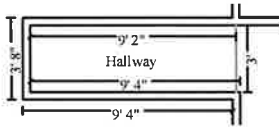

172.00 SF Walls	27.50 SF Ceiling
199.50 SF Walls & Ceiling	27.50 SF Floor
3.06 SY Flooring	21.50 LF Floor Perimeter
21.50 LF Ceil. Perimeter	

Missing Wall

3' X 8'

Opens into LIVING_ROOM

QUANTITY	UNIT	TAX	O&P	RCV	AGE/LIFE	COND.	DEP %	DEPREC.	ACV
Floor preparation for resilient flooring									
27.50 SF	0.52	0.23	2.90	17.43	0/50 yrs	Avg.	0%	(0.00)	17.43
Remove Remove Vinyl tile*									
27.50 SF	1.32	0.00	7.26	43.56	0/50 yrs	Avg.	NA	(0.00)	43.56
Install Install Vinyl tile*									
27.50 SF	1.21	0.00	6.66	39.94	0/50 yrs	Avg.	0%	(0.00)	39.94
Material Only Vinyl tile - Materials Only*									
27.50 SF	2.21	5.09	13.18	79.05	0/50 yrs	Avg.	0%	(0.00)	79.05
Final cleaning - construction - Residential									
27.50 SF	0.37	0.00	2.04	12.22	0/NA	Avg.	0%	(0.00)	12.22
Totals: Hallway		5.32	32.04	192.20				0.00	192.20

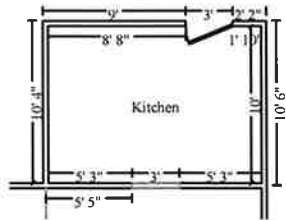

Kitchen

Height: 8'

336.00 SF Walls
 471.00 SF Walls & Ceiling
 15.00 SY Flooring
 47.00 LF Ceil. Perimeter

135.00 SF Ceiling
 135.00 SF Floor
 41.00 LF Floor Perimeter

Missing Wall - Goes to Floor Door

3' X 6' 8"
3' X 6' 8"

Opens into LIVING_ROOM
Opens into Exterior

QUANTITY	UNIT	TAX	O&P	RCV	AGE/LIFE	COND.	DEP %	DEPREC.	ACV
Floor preparation for resilient flooring									
135.00 SF	0.52	1.13	14.26	85.59	0/50 yrs	Avg.	0%	(0.00)	85.59
Remove Remove Vinyl tile*									
135.00 SF	1.32	0.00	35.64	213.84	0/50 yrs	Avg.	NA	(0.00)	213.84
Install Install Vinyl tile*									
135.00 SF	1.21	0.00	32.68	196.03	0/50 yrs	Avg.	0%	(0.00)	196.03
Material Only Vinyl tile - Materials Only*									
135.00 SF	2.21	24.99	64.68	388.02	0/50 yrs	Avg.	0%	(0.00)	388.02
Final cleaning - construction - Residential									
135.00 SF	0.37	0.00	10.00	59.95	0/NA	Avg.	0%	(0.00)	59.95
Dumpster load - Approx. 20 yards, 4 tons of debris									
1.00 EA	455.00	0.00	91.00	546.00	0/NA	Avg.	NA	(0.00)	546.00
Totals: Kitchen		26.12	248.26	1,489.43				0.00	1,489.43
Total: Main Level		234.46	1,638.32	9,829.77				0.00	9,829.77

Labor Minimums Applied

QUANTITY	UNIT	TAX	O&P	RCV	AGE/LIFE	COND.	DEP %	DEPREC.	ACV
Insulation labor minimum									
1.00 EA	68.71	0.00	13.74	82.45	0/NA	Avg.	0%	(0.00)	82.45
Window labor minimum									
1.00 EA	129.08	0.00	25.82	154.90	0/NA	Avg.	0%	(0.00)	154.90
Finish hardware labor minimum									
1.00 EA	129.50	0.00	25.90	155.40	0/NA	Avg.	0%	(0.00)	155.40
General labor - labor minimum									
1.00 EA	1.84	0.00	0.36	2.20	0/NA	Avg.	0%	(0.00)	2.20
Cleaning labor minimum									
1.00 EA	21.79	0.00	4.36	26.15	0/NA	Avg.	0%	(0.00)	26.15
Totals: Labor Minimums Applied		0.00	70.18	421.10				0.00	421.10



Line Item Totals: 23-024968 234.46 1,708.50 10,250.87 0.00 10,250.87

[%] - Indicates that depreciate by percent was used for this item

[M] - Indicates that the depreciation percentage was limited by the maximum allowable depreciation for this item

Grand Total Areas:

1,351.40 SF Walls	328.38 SF Ceiling	1,679.77 SF Walls and Ceiling
328.38 SF Floor	36.49 SY Flooring	157.92 LF Floor Perimeter
587.50 SF Long Wall	587.50 SF Short Wall	175.92 LF Ceil. Perimeter
328.38 Floor Area	363.60 Total Area	839.52 Interior Wall Area
783.69 Exterior Wall Area	93.50 Exterior Perimeter of Walls	
0.00 Surface Area	0.00 Number of Squares	0.00 Total Perimeter Length
0.00 Total Ridge Length	0.00 Total Hip Length	



Summary for Dwelling

Line Item Total		8,307.91
Material Sales Tax		234.46
Subtotal		8,542.37
Overhead		854.25
Profit		854.25
Replacement Cost Value		\$10,250.87
Less Deductible	[Full Deductible = 25,000.00]	(10,250.87)
Net Claim		\$0.00

Jacob Barcus NV



Recap of Taxes, Overhead and Profit

	Overhead (10%)	Profit (10%)	Material Sales Tax (8.375%)	Manuf. Home Tax (8.375%)	Storage Tax (8.375%)
Line Items	854.25	854.25	234.46	0.00	0.00
Total	854.25	854.25	234.46	0.00	0.00



Recap by Room

Estimate: 23-024968

Area: Main Level

Front Elevation	465.81	5.61%
Living Room	6,121.29	73.68%
Hallway	154.84	1.86%
Kitchen	1,215.05	14.63%
<hr/>		
Area Subtotal: Main Level	7,956.99	95.78%
Labor Minimums Applied	350.92	4.22%
<hr/>		
Subtotal of Areas	8,307.91	100.00%
<hr/>		
Total	8,307.91	100.00%



Recap by Category

O&P Items	Total	%
CLEANING	143.30	1.40%
CONCRETE & ASPHALT	1,361.75	13.28%
CONTENT MANIPULATION	79.07	0.77%
GENERAL DEMOLITION	1,091.83	10.65%
DOORS	896.39	8.74%
DRYWALL	887.56	8.66%
ELECTRICAL	472.56	4.61%
FLOOR COVERING - VINYL	1,293.82	12.62%
FINISH HARDWARE	220.50	2.15%
INSULATION	231.79	2.26%
LABOR ONLY	1.84	0.02%
PAINTING	1,087.90	10.61%
WINDOWS - VINYL	410.52	4.00%
WINDOWS - WOOD	129.08	1.26%
O&P Items Subtotal	8,307.91	81.05%
Material Sales Tax	234.46	2.29%
Overhead	854.25	8.33%
Profit	854.25	8.33%
Total	10,250.87	100.00%

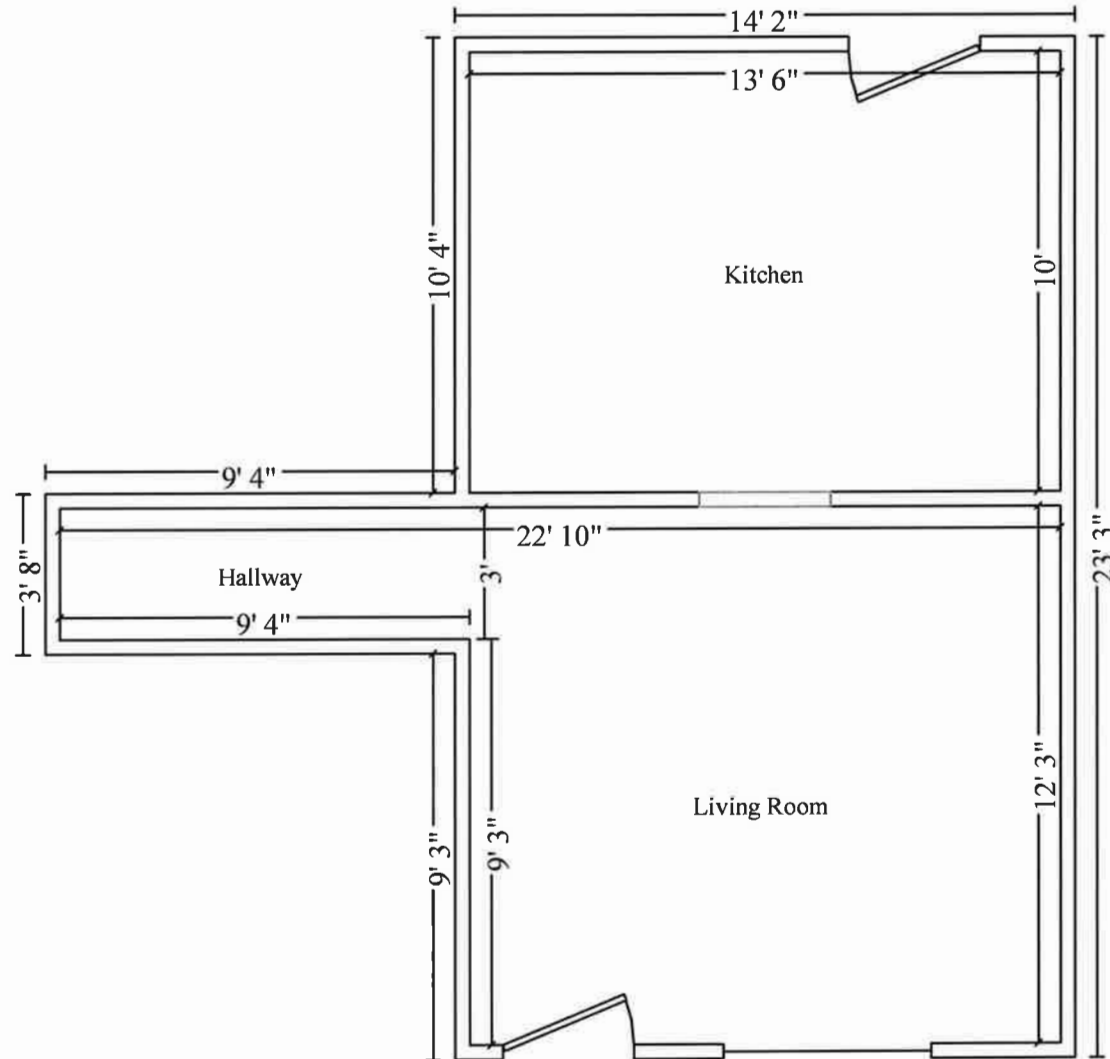

Main Level

A13



A14





A15



A17

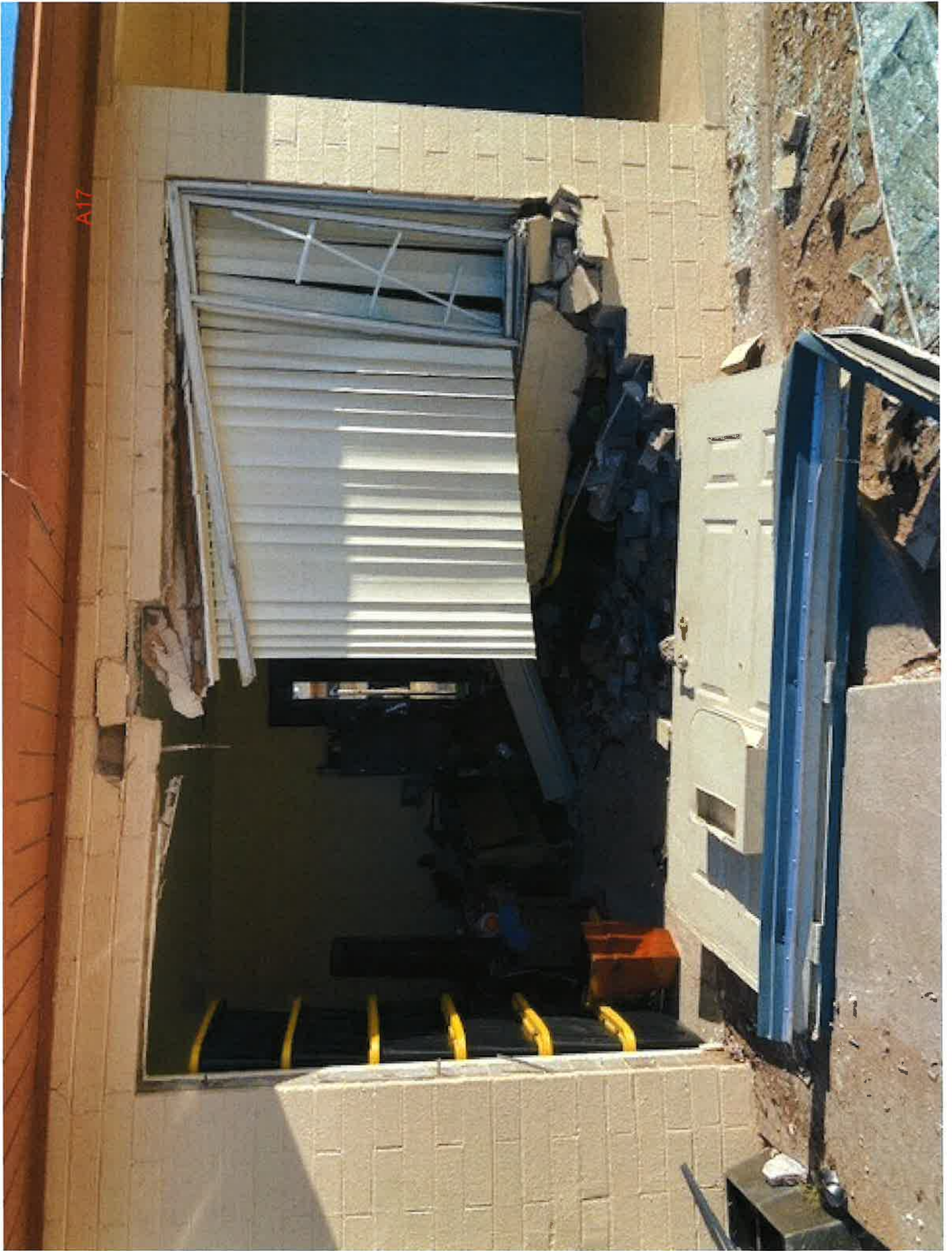

A18

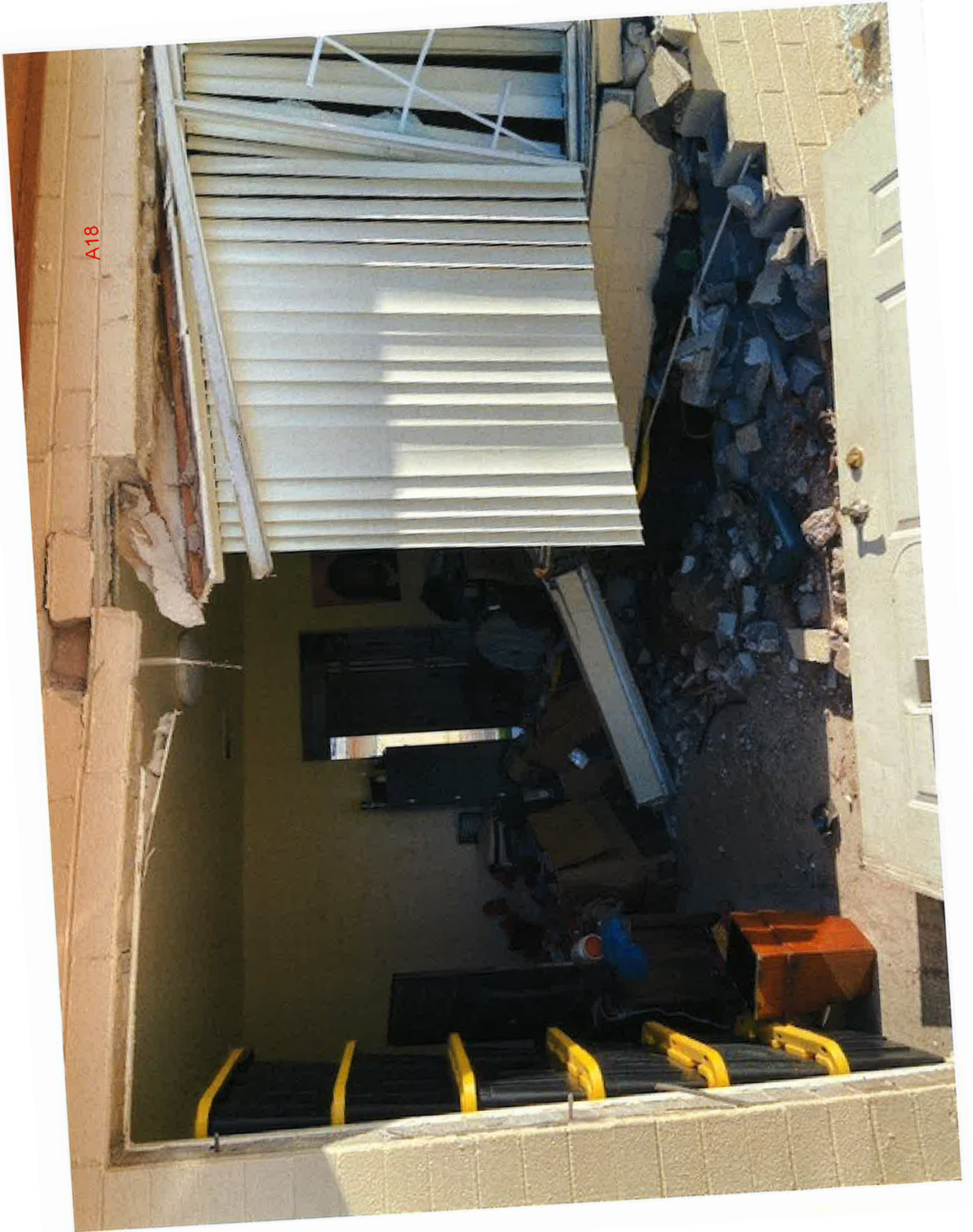

A19



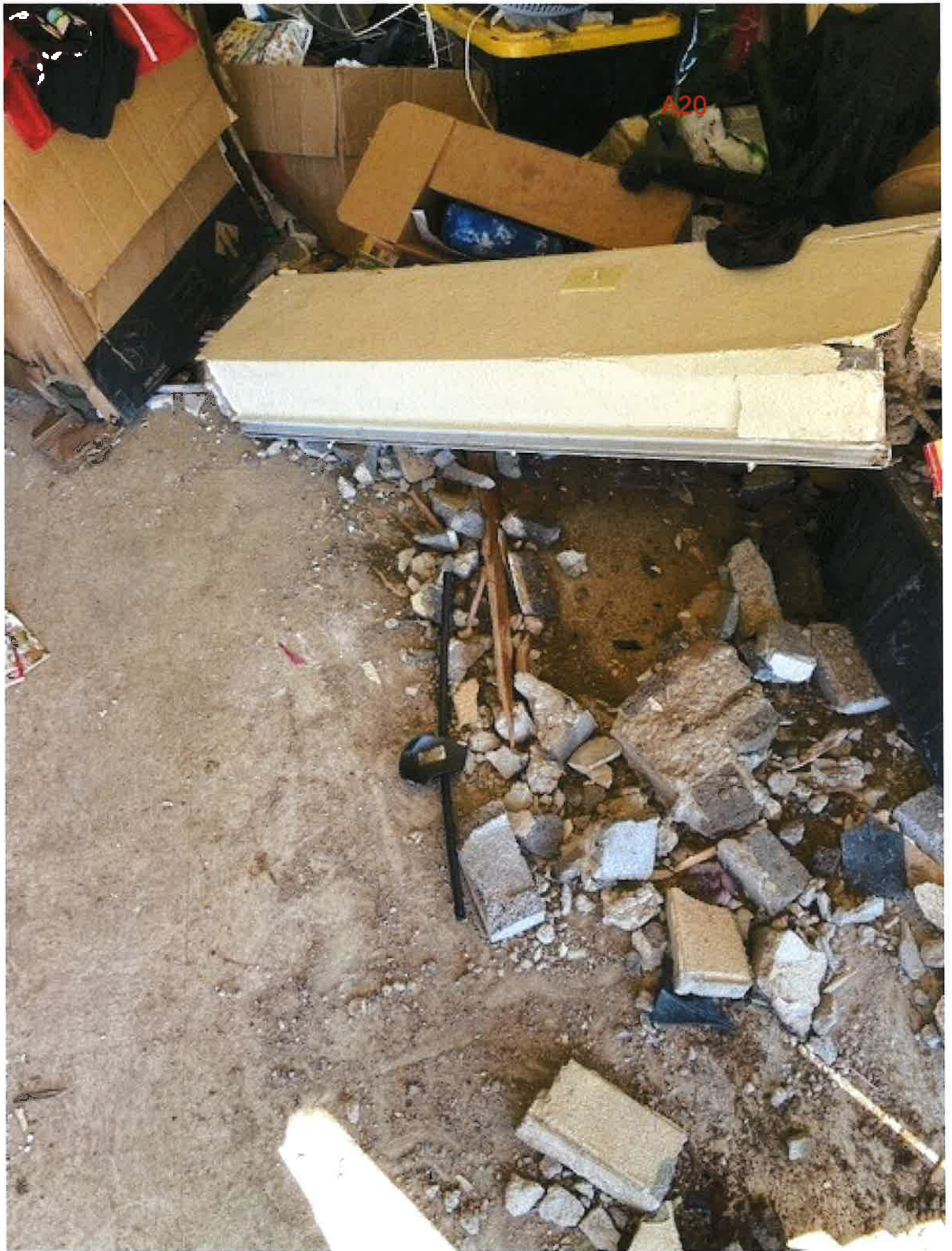

A20

A21

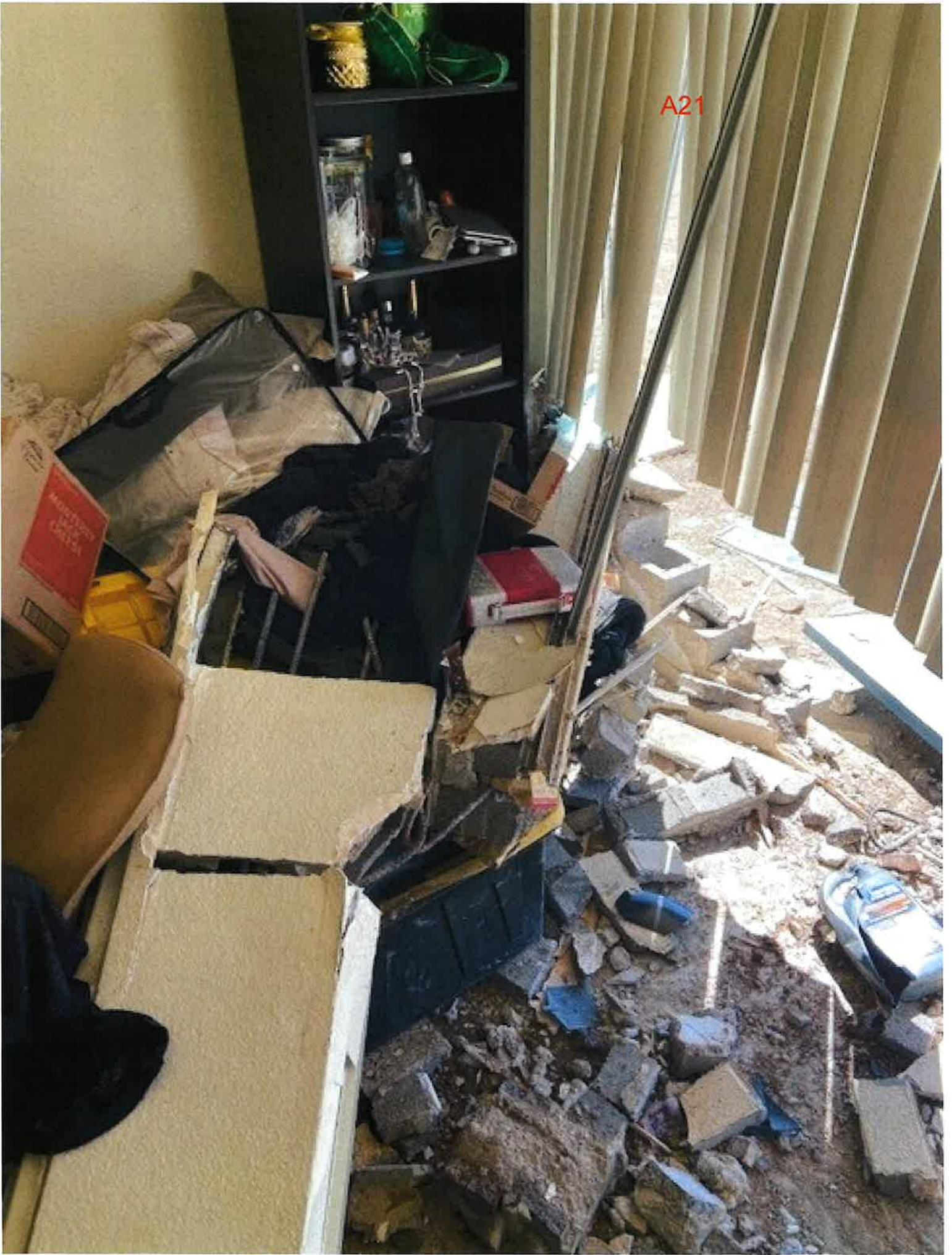

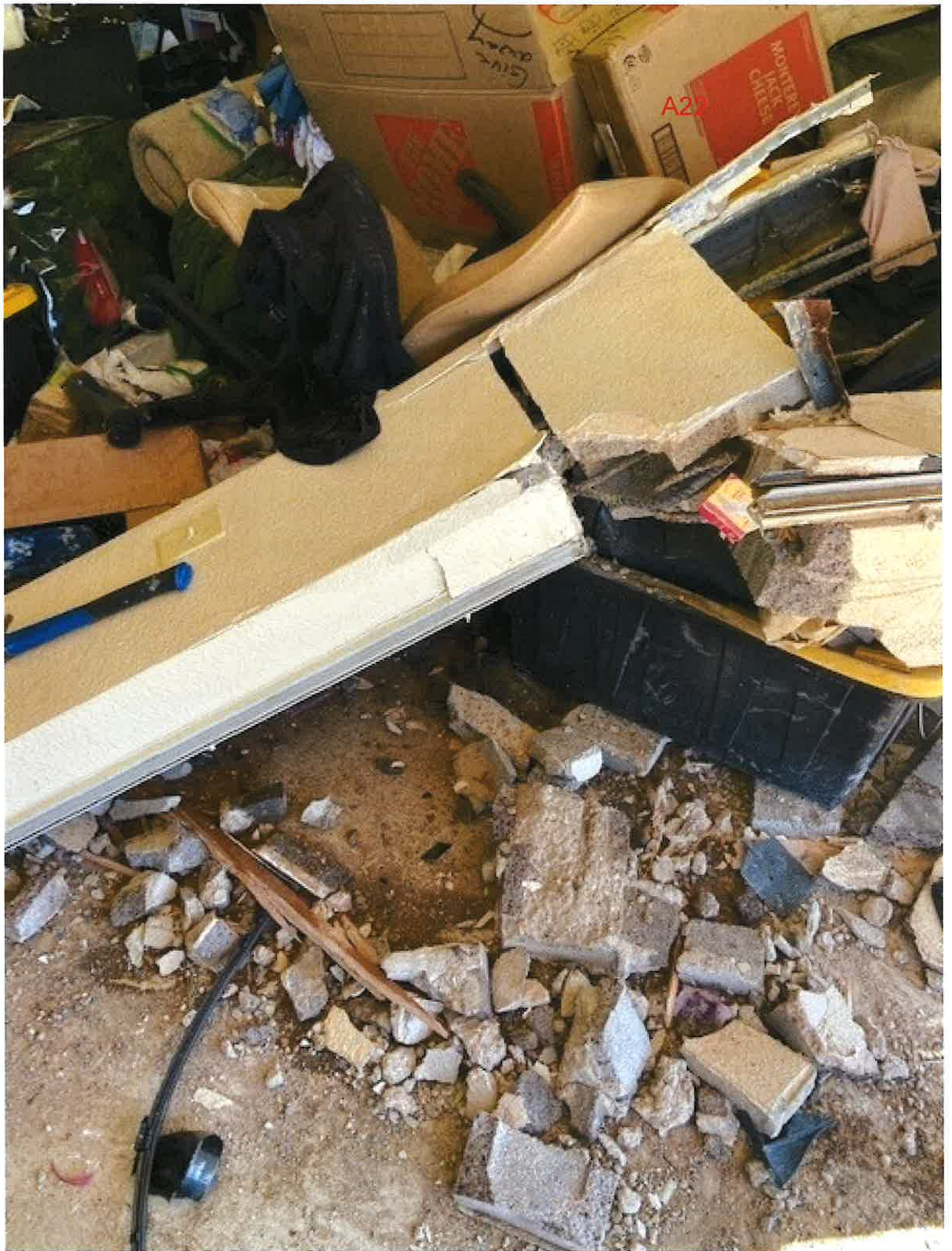

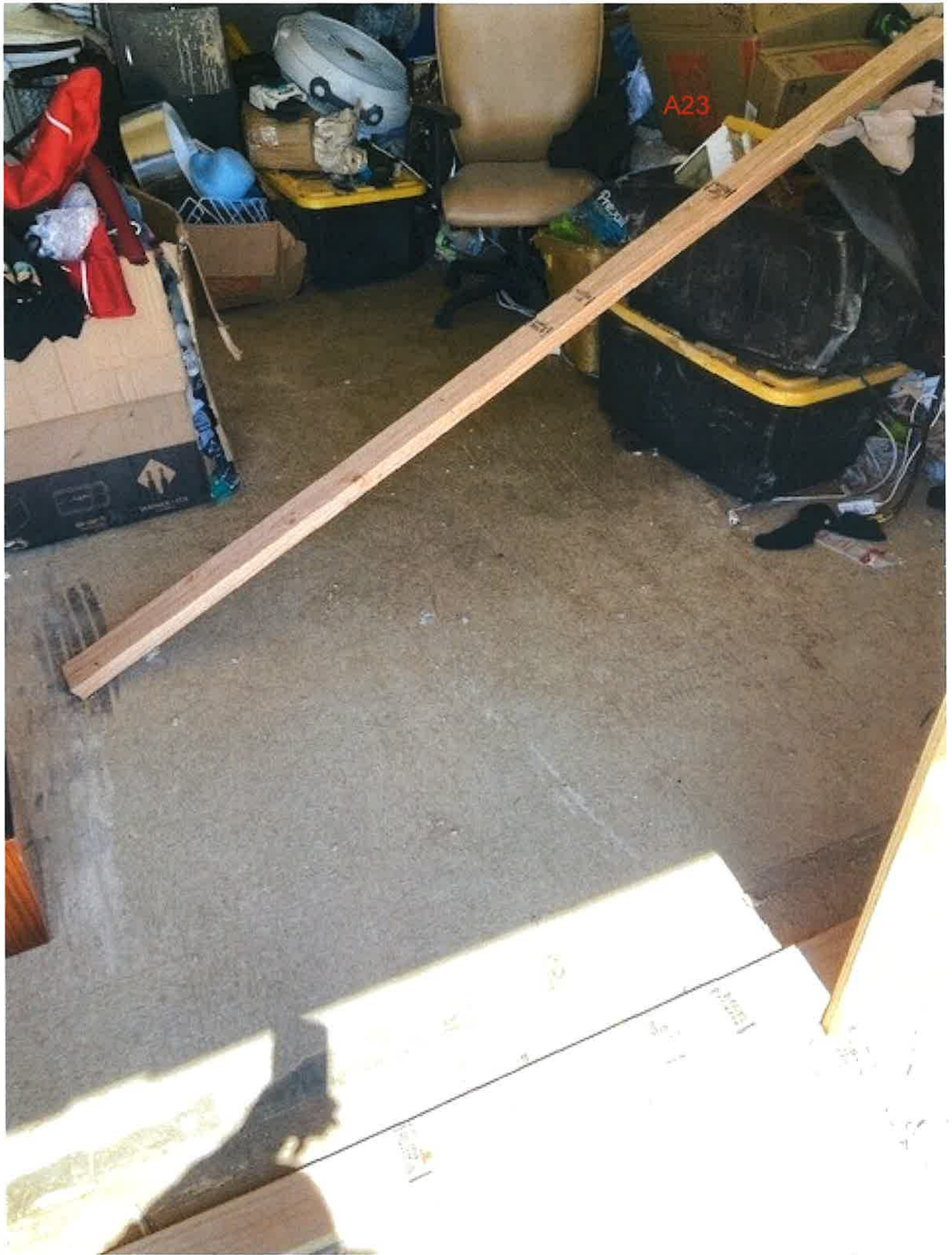

A23

A24

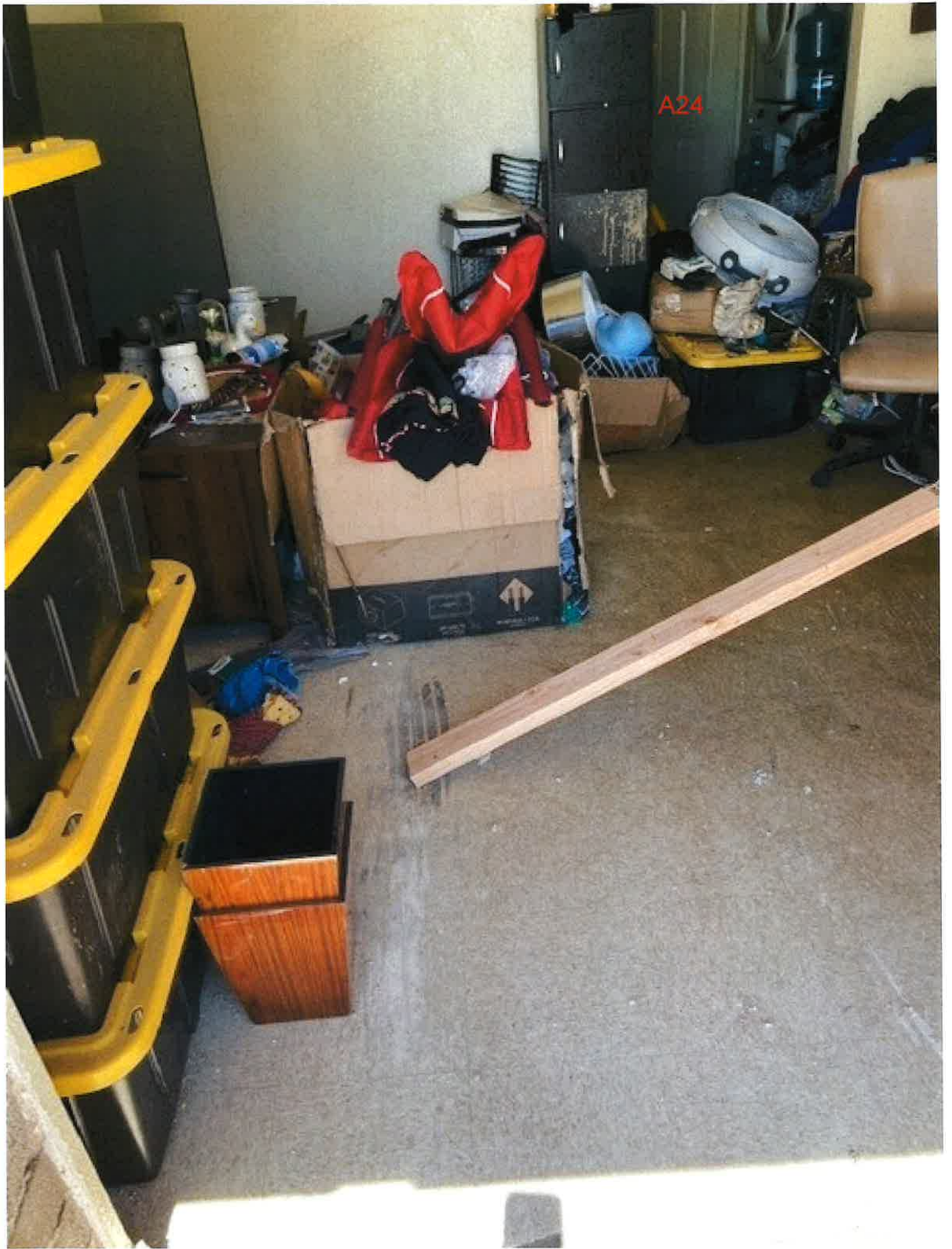

**U.S. Department of Housing
And Urban Development**
Office of Public and Indian Housing

OMB Approval No. 2577-0157 (exp. 1/31/2017)

**Model Form of Agreement Between
Owner and Design Professional**

TASK ORDER NO. 5

NINYO AND MOORE GEOTECHNICAL CORPORATION
CONTRACT NO. C19017
QBS NO: S19017
GEOTECHNICAL AND SPECIAL INSPECTION SERVICES

TERM OF CONTRACT: One (1) Year with an option of four (4) One (1) year Extensions

TERM 1: 05/01/19 – 09/30/19 (4 Months)

OPTIONS YEARS:

TERM 2: 10/01/19 – 09/30/20

TERM 3: 10/01/20 – 09/30/21

TERM 4: 10/01/21 – 09/30/22

TERM 5: 10/01/22 – 09/30/23

TERM 6: 10/01/23 – 04/30/24 (8 Months, Bal. from Yr. 1)

TASK ORDER NO. 05 – Marble Manor
(Prepare Phase 1 Environmental Site Assessment)

Task Order No. 05 Geotechnical and Special Inspection Services – NINYO & MOORE

Addendum (If any)

(Additional Services and other modifications)

This Addendum/Task Order No. 05 modifies the contract noted as Contract No. C19017 between Southern Nevada Regional Housing Authority, hereinafter to as SNRHA (“Owner”) and Ninyo and Moore Geotechnical and Environmental Services Consultants hereinafter referred to as Ninyo and Moore (“Design Professional”) and collectively “Parties”. WHEREAS, Owner and the Design Professional are parties to a contract to provide Geotechnical and Special Inspection Services.

This Addendum represented as Task Order No. 05 is a modification to the above listed contract to perform a new Phase I Environmental Site Assessment of the property known as Marble Manor, a 235-unit family housing development located at 1320 Morgan Ave., Las Vegas, NV 89106 (APN 139-28-702-001). This Task Order No. 05 is issued to address the Geotechnical and Special Inspection Services requested above (Refer to attached Proposal dated August 28, 2023 for details).

Current Contract Amount	\$ 17,536.69
<hr/>	
Field Assessment, Background Research and Data Analysis and Reporting	\$ 3,400.00
<hr/>	
This Task Order	\$ 3,400.00
<hr/>	
New Contract Amount	\$ 20,936.69

This is an Addendum to a Standard Form of Agreement between Owner and Design Professional signed and dated the 1st day of May in the year (yyyy) of 2019 between the Owner Southern Nevada Regional Housing Authority (SNRHA) and Design Professional NINYO & MOORE on Project(s) Marble Manor. The parties to that Agreement agree to modify the Agreement by the above delineated Additional Services and modifications.

This Addendum is dated this 4th day of October in the year (yyyy) of 2023.

Owner

Design Professional

Southern Nevada Regional Housing Authority
(Housing Authority)

NINYO AND MOORE GEOTECHNICAL
(Firm)

(Signature)

(Signature)

Lewis Jordan
(Print Name)

Court Brooks
(Print Name)

Executive Director
(Print Title)

Principal Hydrogeologist
(Print Title)



APPENDIX 1

SCOPE OF WORK FOR REHABILITATION:

802 McWilliams, Las Vegas, NV 89106



APPENDIX 2

SITE VISIT FOLLOWING PRE-BID CONFERENCE

Time may vary a bit (this is only an estimate)

9:30 AM: 802 McWilliams, Las Vegas, NV 89106

Additional site visits available upon request until April 4th 2023, 10AM

Please be advised that all of the above-noted work will be awarded to one Contractor who is the lowest, most responsive, responsible bidder. This project requires a General Contractor's license.



APPENDIX 3

SNRHA'S COVID-19 NOTICE TO CONTRACTORS

PLEASE NOTE: THIS PROTOCOL IS PUT IN PLACE FOR THE SAFETY AND HEALTH OF CONTRACTORS, EMPLOYEES AND RESIDENTS AND IS A REQUIREMENT OF THE CONTRACT AWARD.



APPENDIX 3

SNRHA'S COVID-19 NOTICE TO CONTRACTORS

PLEASE NOTE: THIS PROTOCOL IS PUT IN PLACE FOR THE SAFETY AND HEALTH OF CONTRACTORS, EMPLOYEES AND RESIDENTS AND IS A REQUIREMENT OF THE CONTRACT AWARD.